

电源型号:EI-41-AD9010,9VAC 800mA输入

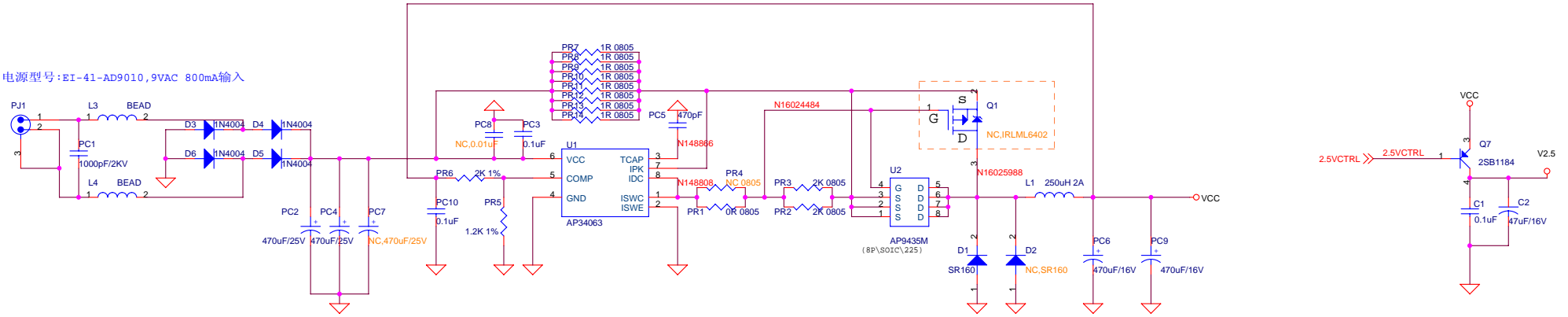

POWER (3.3V/2.5V DC)

RESET

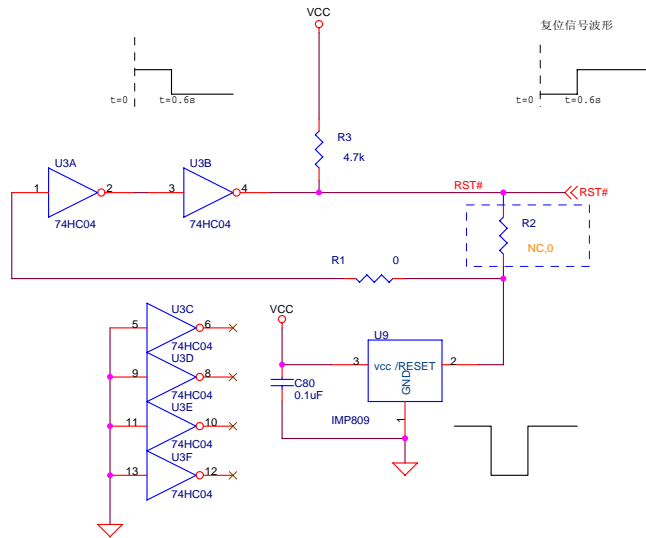

Clock Setting 3,NC

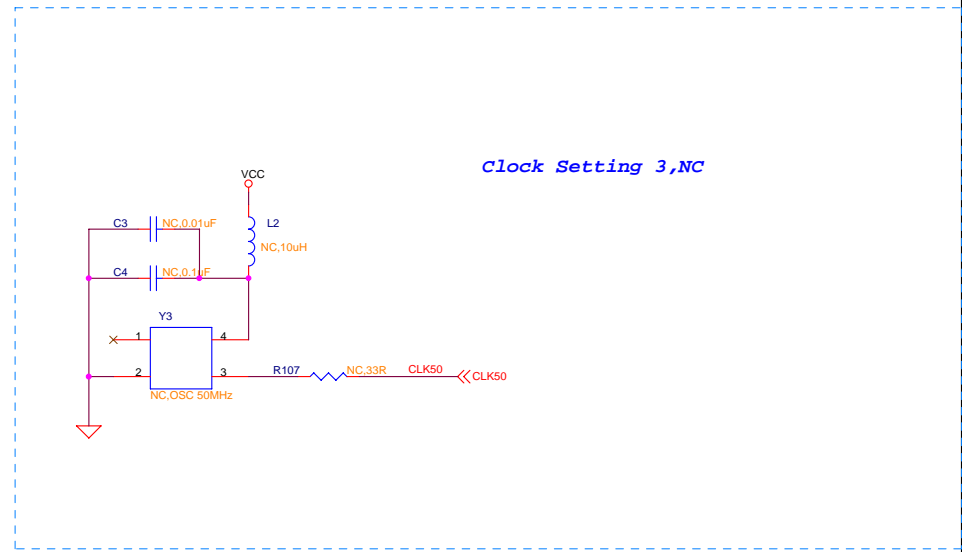

Title			
Size	Document Number	1-Power+Reset	Rev
Custom			2.2(2.3)
Date:	Friday, January 17, 2003	Sheet	1 of 5

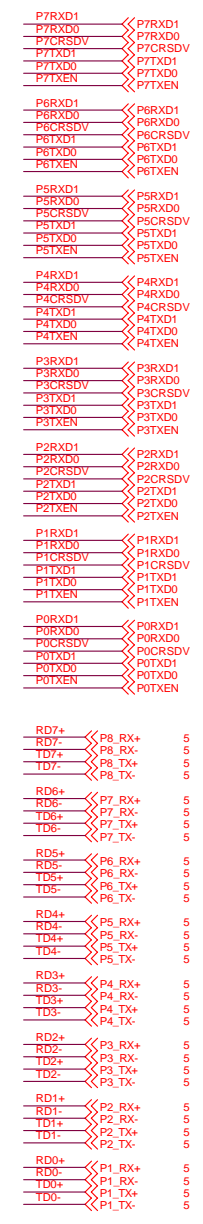
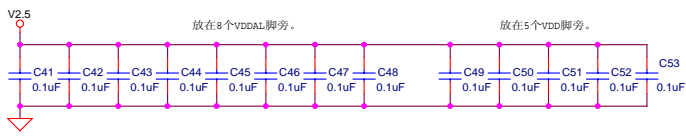
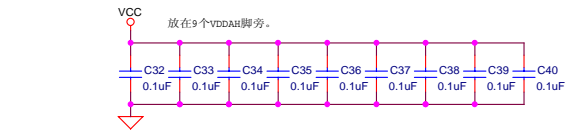
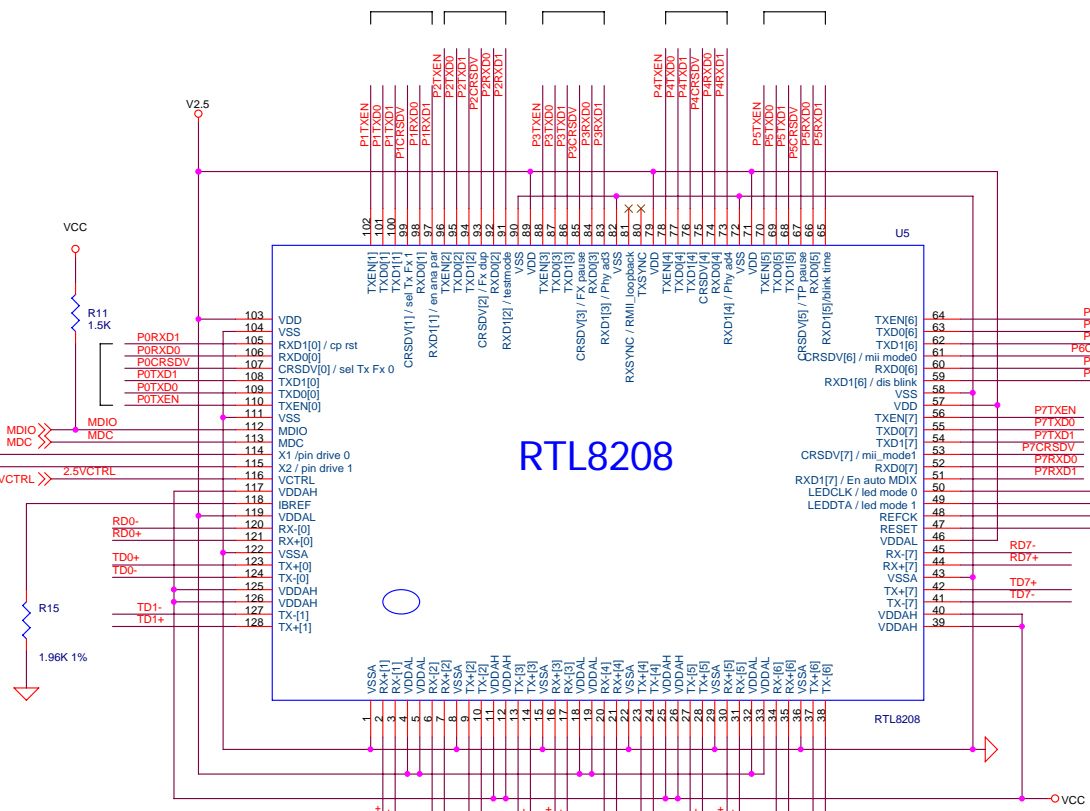
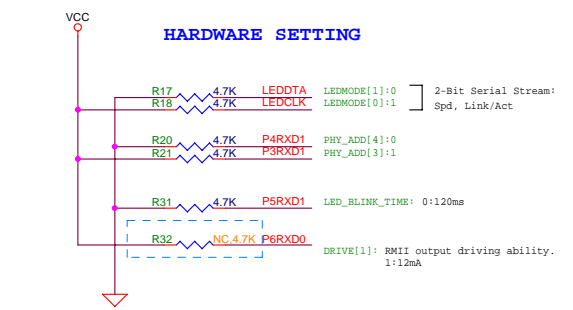
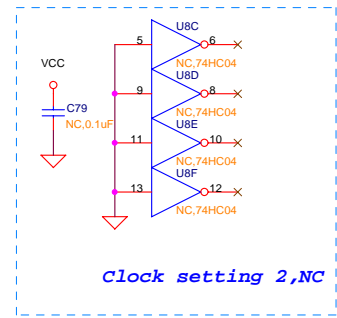
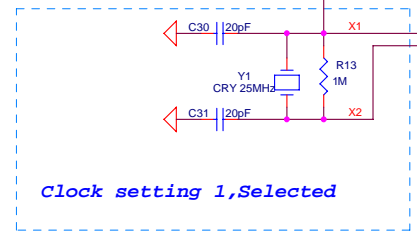
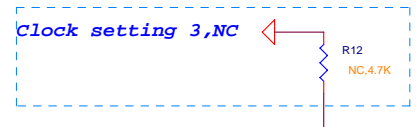
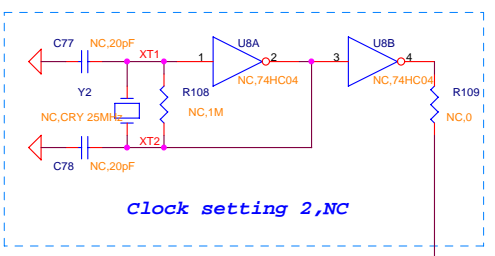

Title		
Size	Document Number	Rev
Custom-Doc>		2.2(2.3)
Date:	Friday, January 17, 2003	Sheet 2 of 5

Enable back pressure.
ENBKPRS R9 (Internal 1) VCC

Broadcast storm control:0--Disabled.
ENBRDCTRL R7 (Internal 0)

Enable full duplex flow control.
ENFCTRL R10 (Internal 1) VCC

Enable store-and-forward mode.
ENCUTHR R8 (Internal 0)

0603

系统时钟输入, 50MHz

参考时钟输入, 50MHz

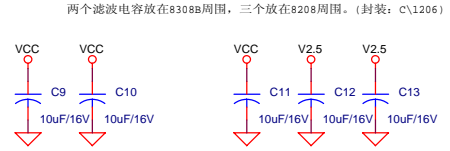
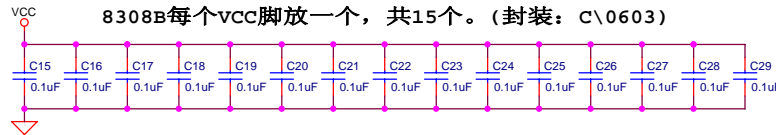

ENBKPRS
ENBRDCTRL
ENFCTRL
ENCUTHR
CLK50

RTL8308B

Port 3

Port7 Port6 Port5 Port4

Port0 Port1 Port2

- P7RXD1 << P7RXD1
- P7RXD0 << P7RXD0
- P7CRSDV << P7CRSDV
- P7TXD1 << P7TXD1
- P7TXD0 << P7TXD0
- P7TXEN << P7TXEN

- P6RXD1 << P6RXD1
- P6RXD0 << P6RXD0
- P6CRSDV << P6CRSDV
- P6TXD1 << P6TXD1
- P6TXD0 << P6TXD0
- P6TXEN << P6TXEN

- P5RXD1 << P5RXD1
- P5RXD0 << P5RXD0
- P5CRSDV << P5CRSDV
- P5TXD1 << P5TXD1
- P5TXD0 << P5TXD0
- P5TXEN << P5TXEN

- P4RXD1 << P4RXD1
- P4RXD0 << P4RXD0
- P4CRSDV << P4CRSDV
- P4TXD1 << P4TXD1
- P4TXD0 << P4TXD0
- P4TXEN << P4TXEN

- P3RXD1 << P3RXD1
- P3RXD0 << P3RXD0
- P3CRSDV << P3CRSDV
- P3TXD1 << P3TXD1
- P3TXD0 << P3TXD0
- P3TXEN << P3TXEN

- P2RXD1 << P2RXD1
- P2RXD0 << P2RXD0
- P2CRSDV << P2CRSDV
- P2TXD1 << P2TXD1
- P2TXD0 << P2TXD0
- P2TXEN << P2TXEN

- P1RXD1 << P1RXD1
- P1RXD0 << P1RXD0
- P1CRSDV << P1CRSDV
- P1TXD1 << P1TXD1
- P1TXD0 << P1TXD0
- P1TXEN << P1TXEN

- P0RXD1 << P0RXD1
- P0RXD0 << P0RXD0
- P0CRSDV << P0CRSDV
- P0TXD1 << P0TXD1
- P0TXD0 << P0TXD0
- P0TXEN << P0TXEN

Title		
Size	Document Number	Rev
Custom<Doc>		2.2(2.3)
Date:	Friday, January 17, 2003	Sheet 3 of 5

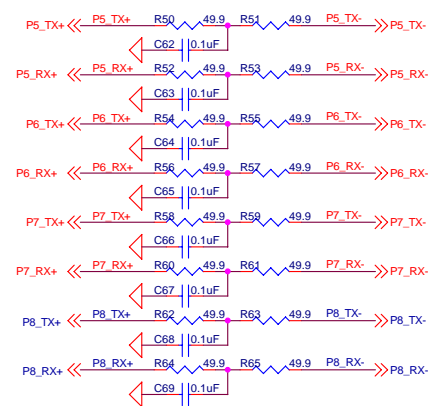
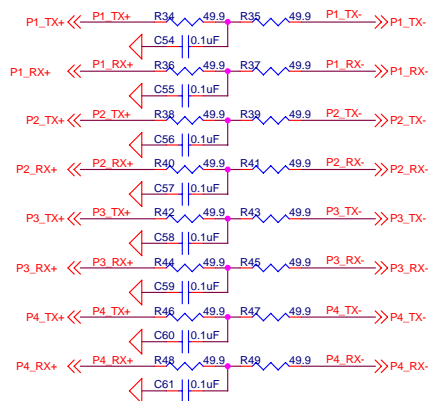

UPLINK PORT

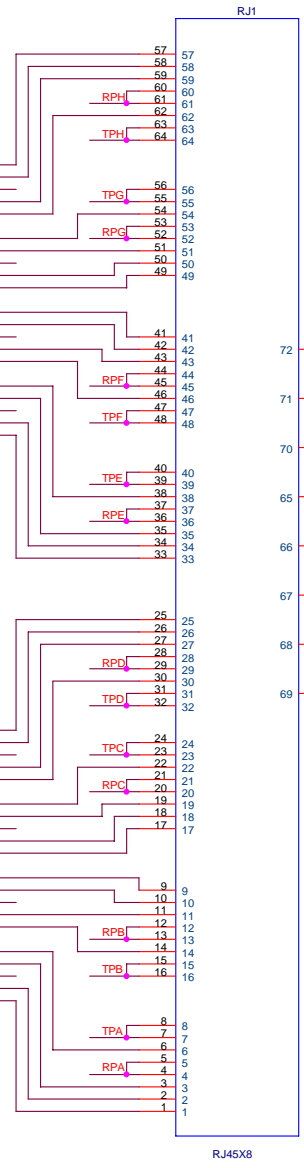
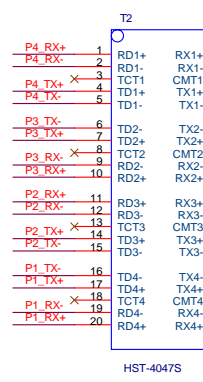
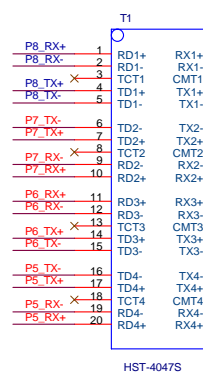
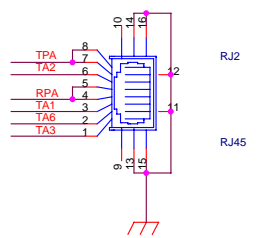

PORT8

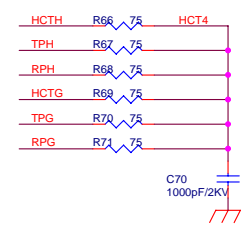

PORT7

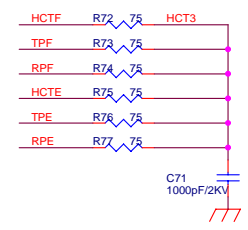

PORT5

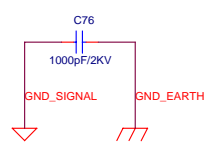

PORT4

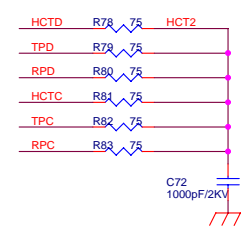

PORT2

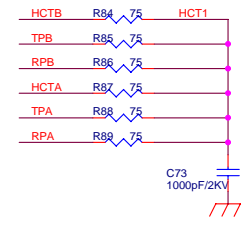

PORT1

Title		
Size	Document Number	Rev
Custom-Doc>		2.2(2.3)
Date:	Friday, January 17, 2003	Sheet 4 of 5

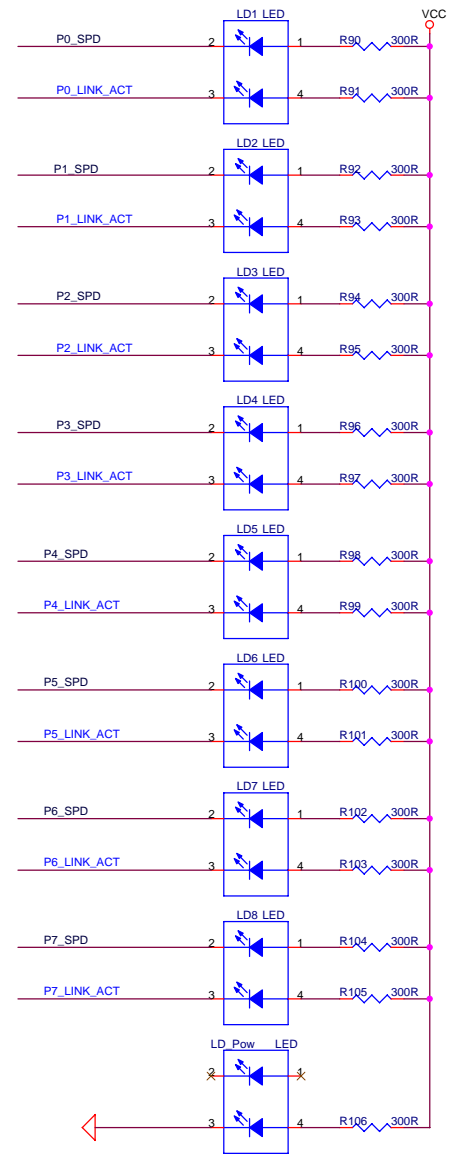
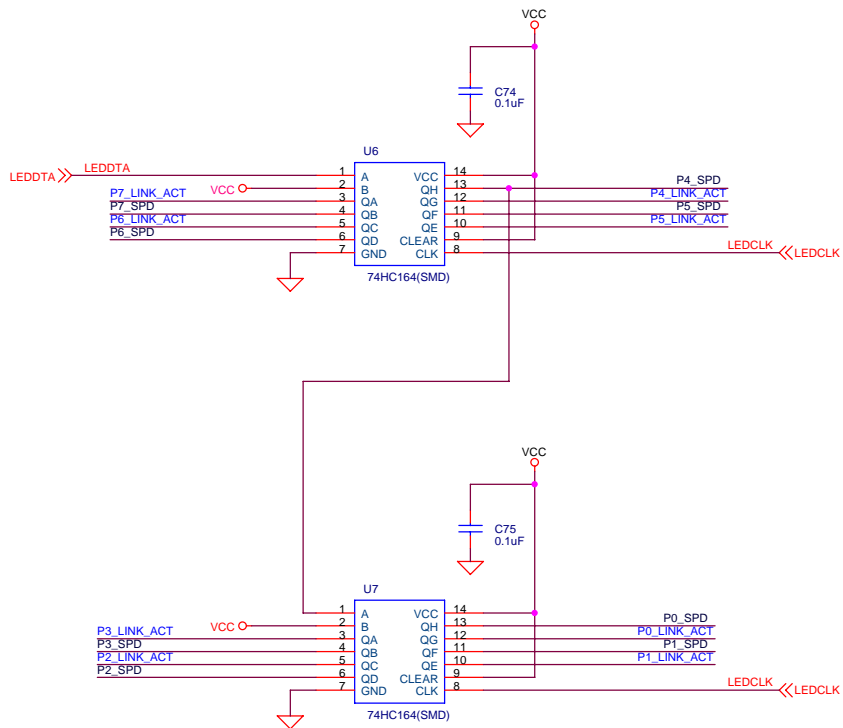

Title		
Size	Document Number	Rev
	Custom <Doc>	2(2.3)
Date:	Friday, January 17, 2003	Sheet 5 of 5