

Demystifying Auto-Zero Amplifiers—2

They essentially eliminate offset, drift, and 1/f noise. Here are some design ideas.

by Eric Nolan and Reza Moghimi

Part 1 of this two-part article explains how auto-zero amplifiers work and identifies their important characteristics. As promised, this installment will discuss a few application ideas that are particularly well suited to auto-zero amplifiers

Applying auto-zero amplifiers really is not much different from applying any operational amplifier. Most new designs have the same pinout and functionality as any other amplifier. DC closed-loop gain is set by resistors in the same manner; functions such as filtering, integration, and the like can be done in the same way. In most applications, the principal accommodation will be limiting the bandwidth to exclude the chopping noise and IMD artifacts from the passband. For auto-zero amplifiers with fixed-chopper frequency, this generally limits their application to dc or low-frequency signals below 1 or 2 kHz.

PRECISION CURRENT SHUNTS

A precision shunt current sensor benefits by some of the unique attributes of auto-zero amplifiers used in a differencing configuration (Figure 1). Shunt current sensors are used in precision current sources for feedback control systems. They are also used in a variety of other applications, including battery fuel gauging, torque feedback controls in electric power steering and precision power metering.

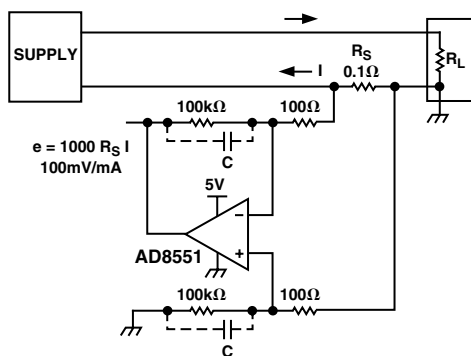

Figure 1. Current shunt amplifier.

In such applications, it is desirable to use a shunt with very low resistance to minimize the series voltage drop; this minimizes the waste of power and allows the measurement of high currents without significant voltage drop. A typical shunt might be 0.1 Ω. At measured current values of 1+ amperes, the shunt's output signal is hundreds of millivolts, or even volts, and amplifier error sources are not critical. However, at low measured current values in the 1-mA range, the 100-μV output voltage of the shunt demands a very low offset voltage and drift to maintain absolute accuracy. Low input bias currents are also needed, so that "injected" bias current does not become a significant percentage of the measured current. High open-loop gain, CMR, and PSR all help to maintain the overall circuit accuracy. As long as the rate of change of the

current is not too large, a fixed-frequency auto-zero amplifier can be used with excellent results.

It is generally desirable to limit the signal bandwidth to the lowest value needed, since this minimizes the effect of the chopping clock noise and also minimizes total noise. Remember that total voltage noise for an auto-zero amplifier is proportional to the square root of the signal bandwidth ($E_N = e_N \times \sqrt{BW}$). A simple low-pass filter can be created by adding optional capacitors (C) in parallel with the feedback resistors. Additional gain and filtering at amplified voltage levels can be provided by an additional stage using ordinary amplifiers. With their high open-loop gain, auto-zero amplifiers can easily provide closed-loop gains of 100× to 1000×, permitting inexpensive CMOS amplifiers with several millivolts of offset and fairly high voltage noise to be used in the following stage without sacrificing system accuracy. Using a high stage gain for the auto-zero amplifier can also add an extra pole to the filter roll-off if the amplifier's gain-bandwidth divided by the stage gain is less than half the chopping clock frequency. However, filter performance will be affected by variations in GBW from amplifier to amplifier.

If the signal frequency exceeds about half the chopping clock frequency, an auto-zero amplifier type with a pseudorandom clock rate, such as the AD8571, can be used. In this case, the maximum overall accuracy will be slightly degraded due to the slightly higher wideband noise and the higher bandwidth; but the chopping clock will not produce a large error term at the clock frequency, and the effects of IMD will be minimized.

STRAIN BRIDGES

Another common application, where the low offset and related low-frequency performance help to achieve wide dynamic range, is with strain bridges. Used in force and pressure sensors and in weigh scales, these bridges usually produce a relatively small output voltage level, even at full scale. In this example, three of the four amplifiers in a quad AD8554 are used for excitation and differential amplification (see Figure 2). The full-scale output may be a few tens of millivolts. In this case, the very low offset voltage of the auto-zero amplifier contributes minimal error to the measured signal. The long sample times of weigh scales benefit from the lack of 1/f noise. The low long-term drift of the amplifiers also minimizes or eliminates recalibration requirements.

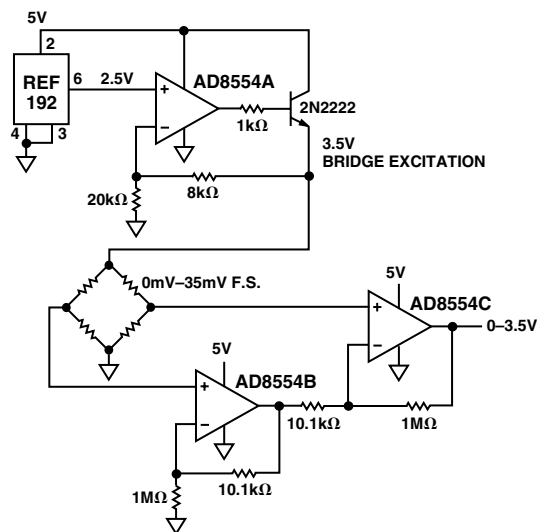

Figure 2. Single-supply strain-gauge bridge amplifier.

Pressure sensor systems, which usually require linearization to produce accurate output values, benefit from the low offset and drift. A well-characterized sensor can be scaled and linearized without concern for interaction with the amplifier, since the added amplifier error terms are negligible. The low input bias currents enable the use of higher bridge impedances, too; this can significantly improve system power consumption in portable or loop-powered applications, because the bridge excitation current can be much lower for the same output range. The lower bridge excitation current also minimizes errors due to bridge self-heating. Most strain-gauge bridge applications are low-frequency by nature, so the limited useful bandwidth of fixed-frequency auto-zero amplifiers is not an issue. The use of bridges with higher frequency outputs or with ac excitation can be accommodated through the use of randomly clocked auto-zero amplifiers.

INFRARED (IR) SENSORS

Infrared (IR) sensors, particularly thermopiles, are increasingly being used in temperature measurement for applications as wide-ranging as automotive climate controls, human ear thermometers, home-insulation analysis and automotive-repair diagnostics. The relatively small output signal of the sensor demands high gain with very low offset voltage and drift to avoid dc errors. If interstage ac coupling is used (Figure 3), the low offset and drift prevents the input amplifier's output from drifting close to saturation. The low input bias currents generate minimal errors from the sensor's output impedance. As with pressure sensors, the very low amplifier drift with time and temperature eliminates additional errors once the temperature measurement has been calibrated. The low 1/f noise improves SNR for dc measurements taken over periods often exceeding 1/5 second. Figure 3 shows an amplifier that can bring ac signals from 100 to 300 microvolts up to the 1 to 3-V level.

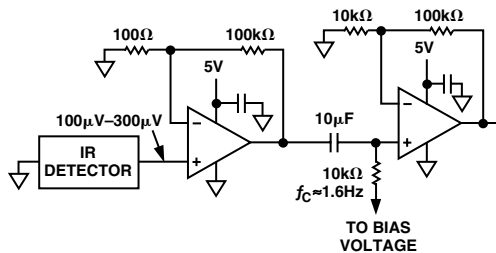
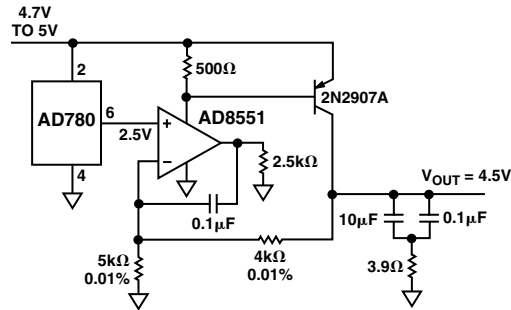

Figure 3. High-input-impedance ac-coupled preamplifier for thermopile.

PRECISION REFERENCES (FIGURE 4)

Precision voltage reference ICs in low-voltage systems may lack the flexibility to handle all the jobs they are called upon to do. For example, (a) they may require low dropout voltage, or (b) they may have to handle sourcing and sinking load currents, or (c) the system in which they are used may simply need a negative reference in addition to the positive reference. With their extremely low offsets and drift, their output drive capability, and the use of active

feedback, auto-zero amplifiers teamed up with precision references can provide effective solutions to these problems.



a. Regulated 4.5 V from a supply as low as 4.7 V.

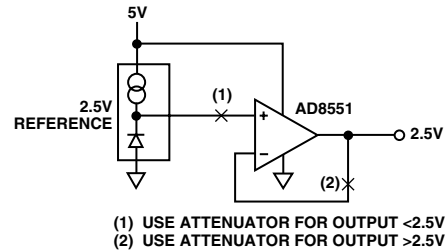

b. Simple buffering.

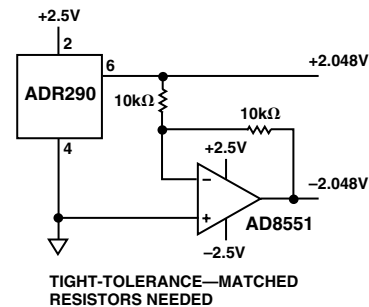

c. ±2.048-V reference from ±2.5-V supply.

Figure 4. Precision amplifiers enhance flexibility of precision references.

The above are just a few ideas to suggest the wide applicability of auto-zero amplifiers. Almost any application that deals with small input signals and wide dynamic range over a moderate signal bandwidth is worthy of consideration for performance improvement using an auto-zero amplifier. Systems that are calibrated and must maintain performance over extended periods without maintenance will also benefit. Any application requiring tight channel-to-channel matching of dc performance is also a candidate. The dc error contributions of high-gain auto-zero amplifiers are so small that using multichannel, or even single-channel, devices will not substantially degrade the matching of multiple input channels. Multiple devices (duals and quads) will also be helpful with matched low-frequency ac inputs.