

- Note:**
1. LAN part is described on page 1-3.
 2. Circuit of the 2nd PCI device depends on the maker of it.
 3. All PCI pins of modem are shared with LAN, except for IDSEL, REQB and GNTB that are connected to RTL8139DL.

Title		
TCL Networks Equipment Co., LTD		
Size	Document Number	Rev
B	NIC 10'100BASE 8139DL	1.10
Date:	Sunday, June 22, 2003	Sheet 4 of 4

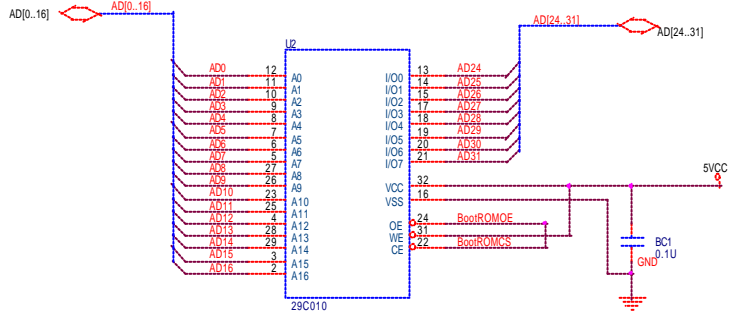
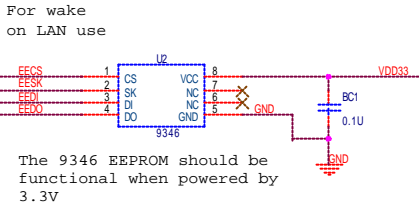
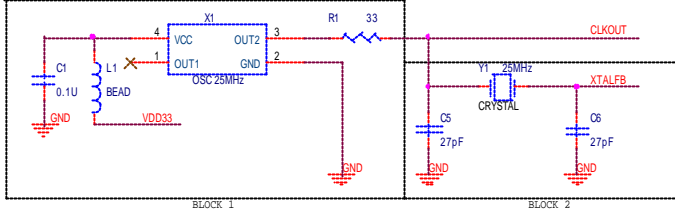
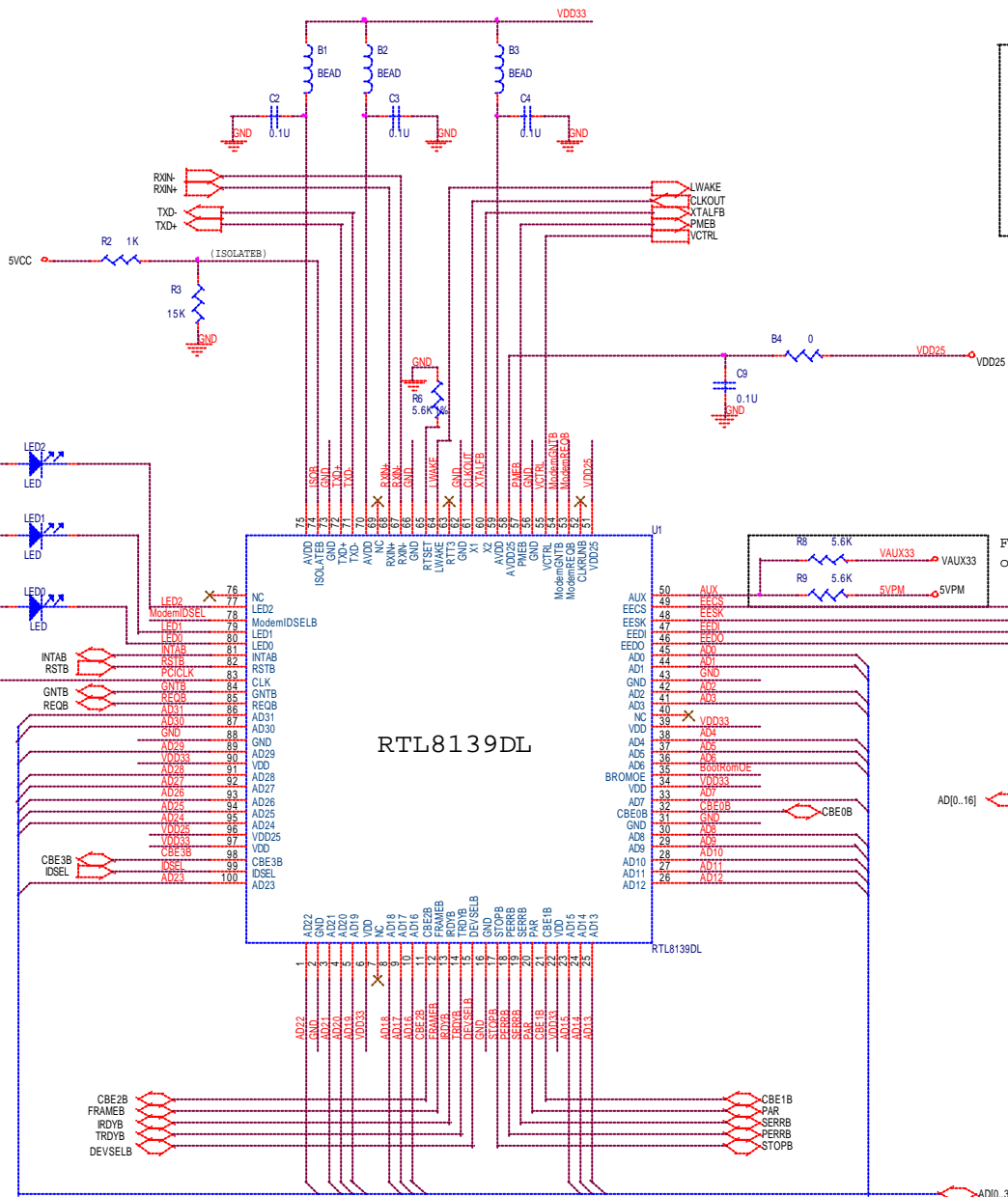

Title		
TCL Networks Equipment Co., LTD		
Size	Document Number	Rev
A3	NIC 10/100BASE 8139DL	1.10
Date:	Sunday, June 22, 2003	Sheet 1 of 4

Important:

*For lump VAUX, C12 must be large enough to avoid power supply's compatibility

*For RTL8139DL application, all bead must be rated 300mA/100ohm@100MHz

Note: The 2.5V must be powered up before 3.3V.

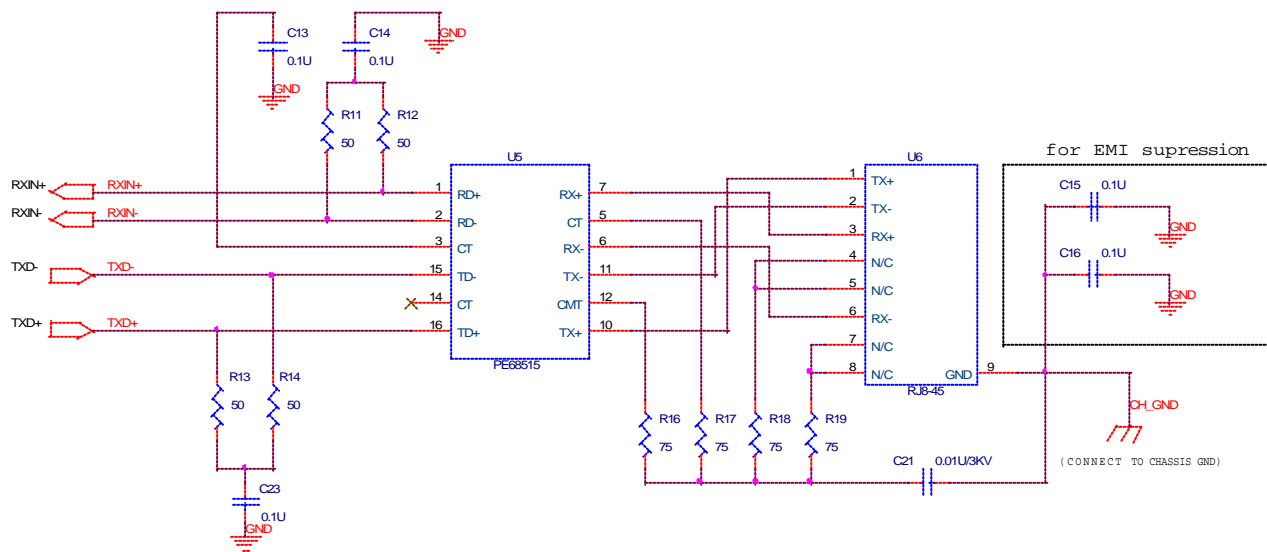
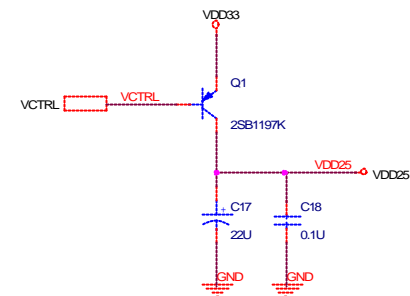
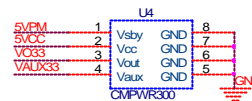
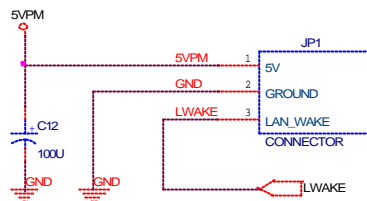
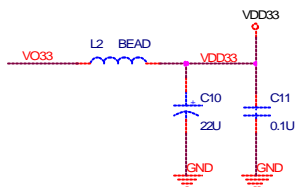

Title		
TCL Networks Equipment Co.LTD		
Size	Document Number	Rev
B	NIC 10'100 BASE 8139DL	1.10
Date:	Sunday, June 22, 2003	Sheet 2 of 4

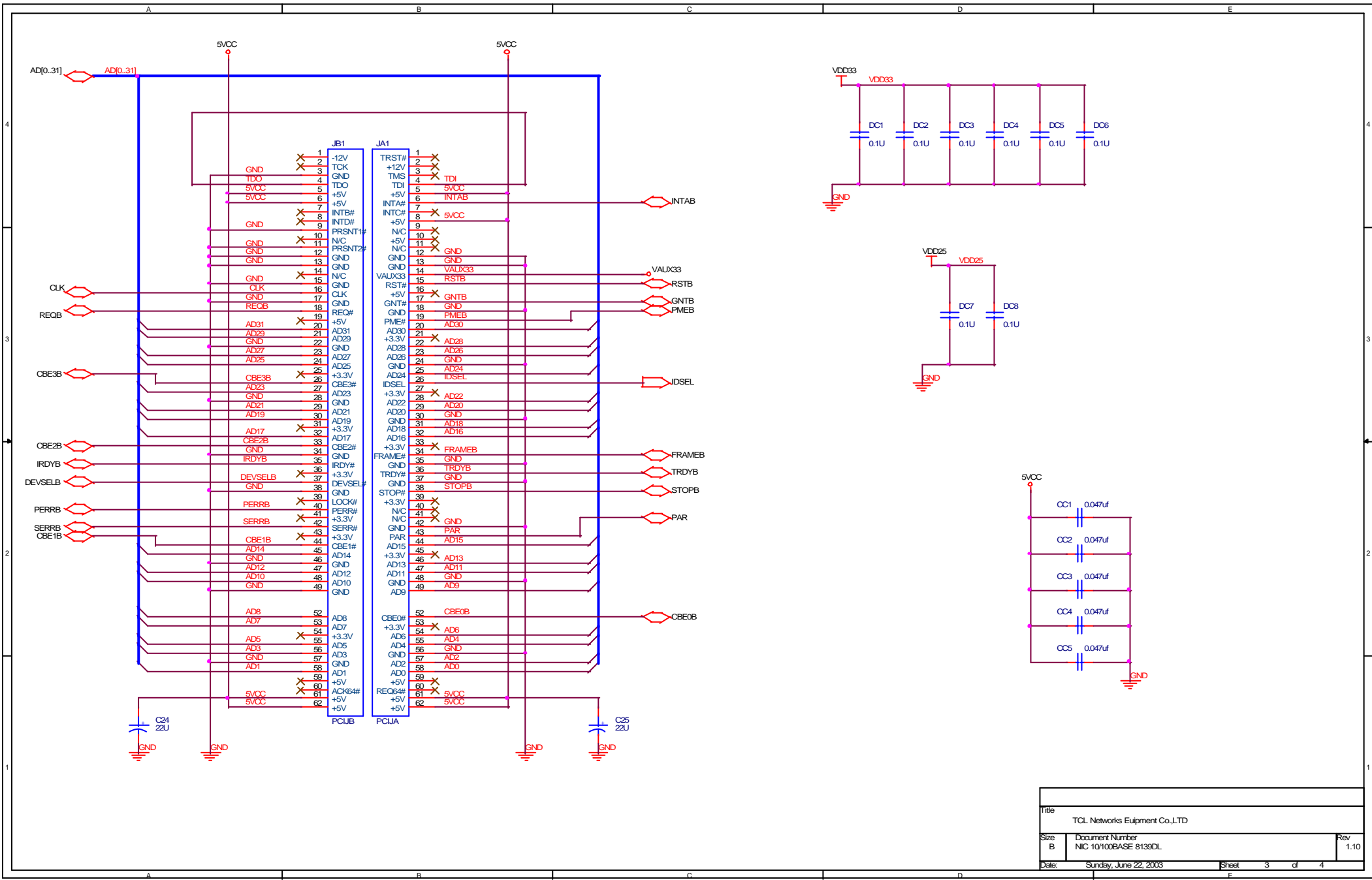

Title		
TCL Networks Equipment Co.,LTD		
Size	Document Number	Rev
B	NIC 10100BASE 8139DL	1.10
Date:	Sunday, June 22, 2003	Sheet 3 of 4