

SHENZHEN KINGTECH ELECTRONICS CO.,LTD		
Title 24-Port Fast-Ethernet Switch Controller(Mem & Led interface)		
Size B	Document Number TP-LINK 82224-1.1	Rev 1.1
Date: Tuesday, June 26, 2001	Sheet 2	of 20

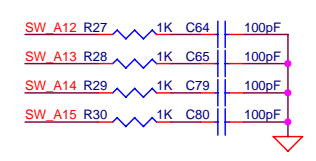

SHENZHEN KINGTECH ELECTRONICS CO.,LTD		
Title: Switch-Controller Memory		
Size: B	Document Number: TP-LINK 82224	Rev: 1.1
Date: Tuesday, June 26, 2001	Sheet: 3	of 20

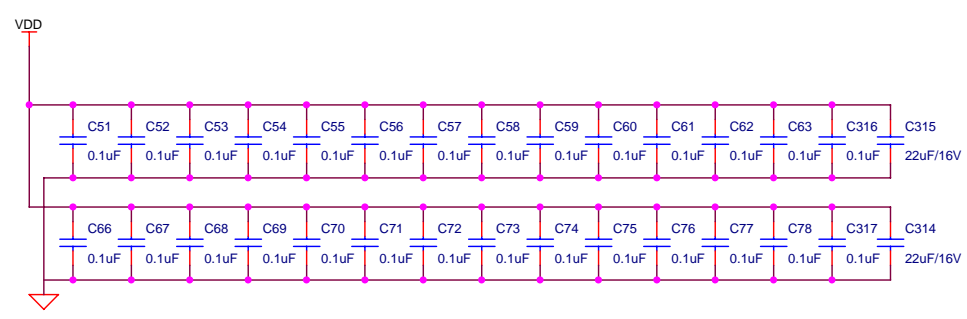
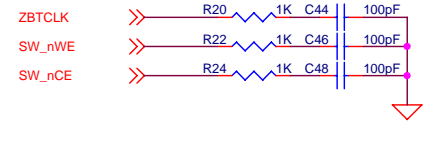
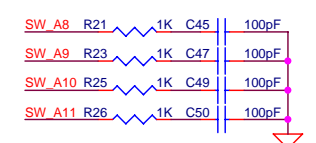
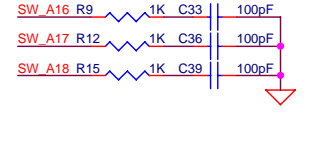
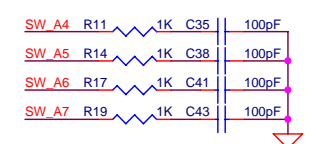
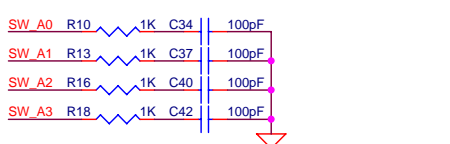
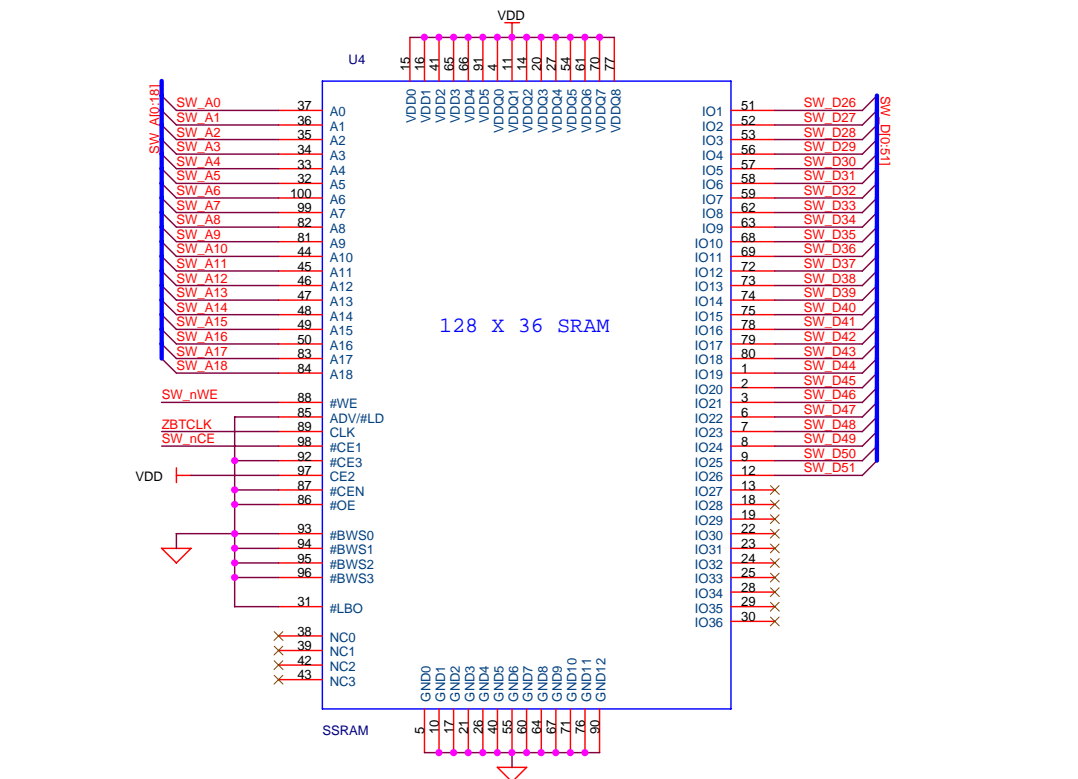
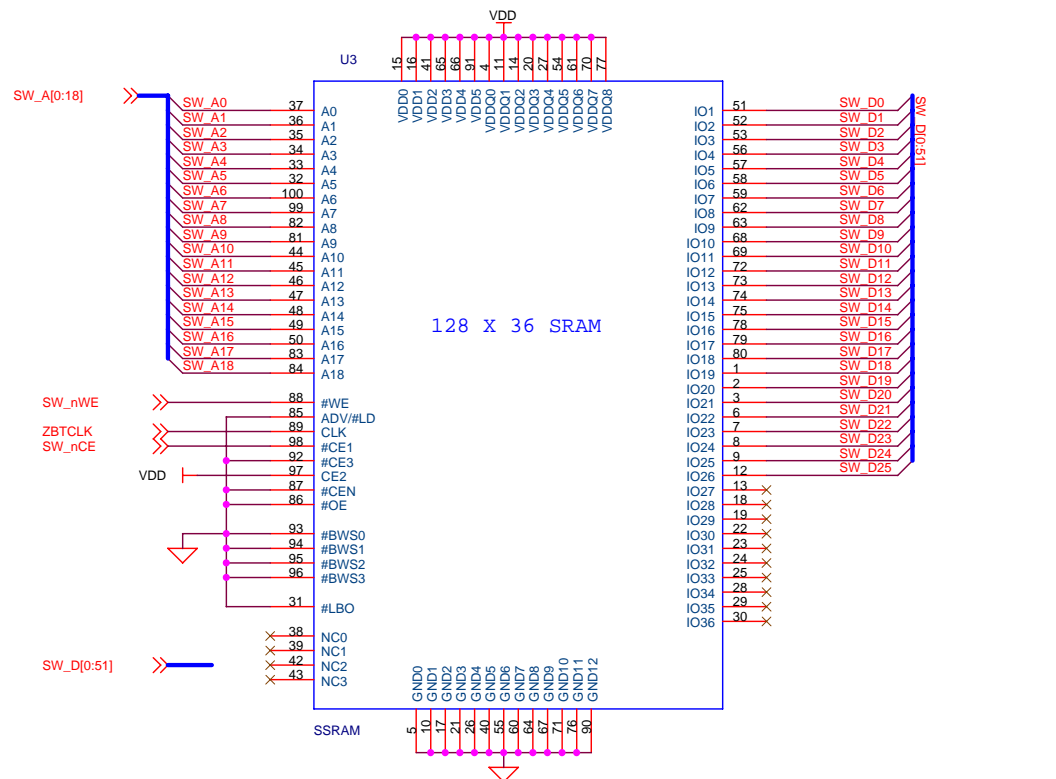
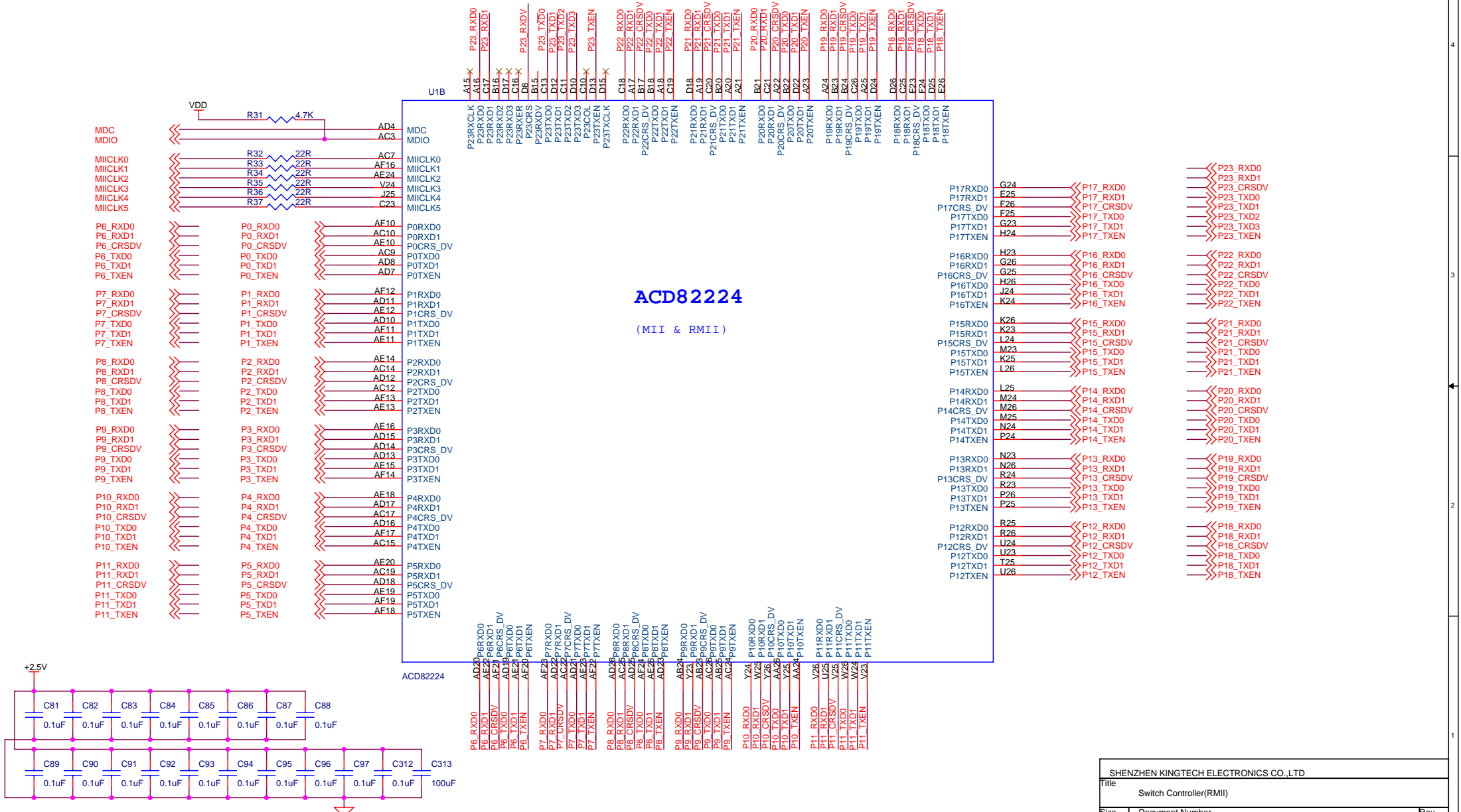

ACD82224
(MII & RMII)

SHENZHEN KINGTECH ELECTRONICS CO.,LTD		
Title	Switch Controller(RMII)	
Size	Document Number	Rev
B	TP-LINK 82224	1.1
Date:	Tuesday, June 26, 2001	Sheet 4 of 20

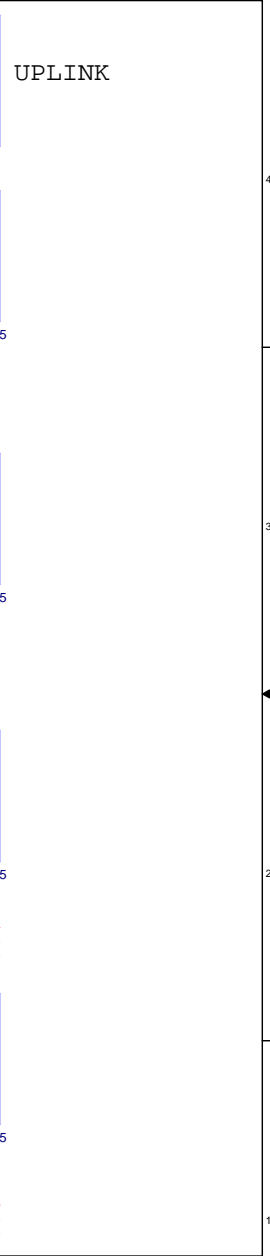
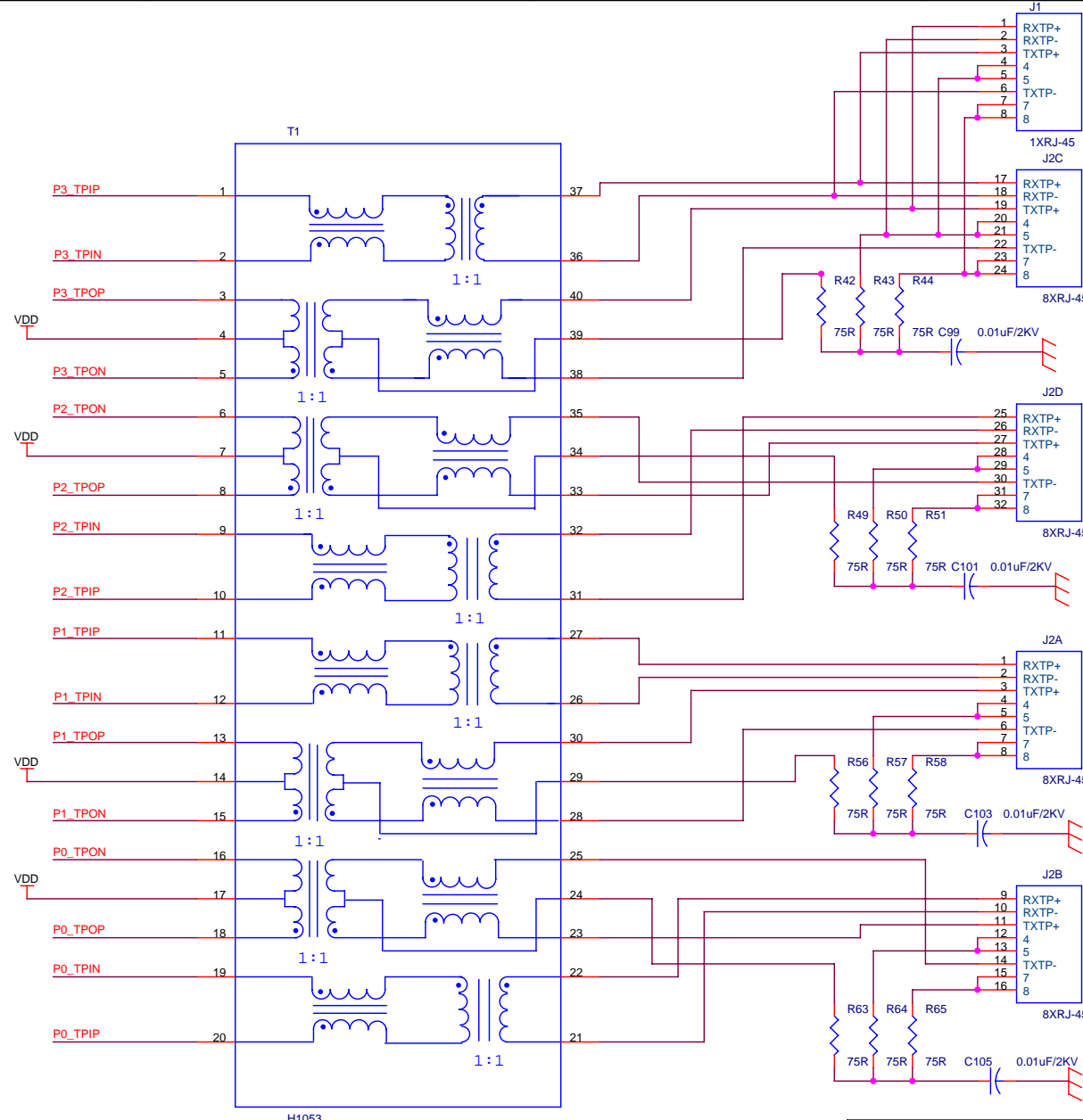
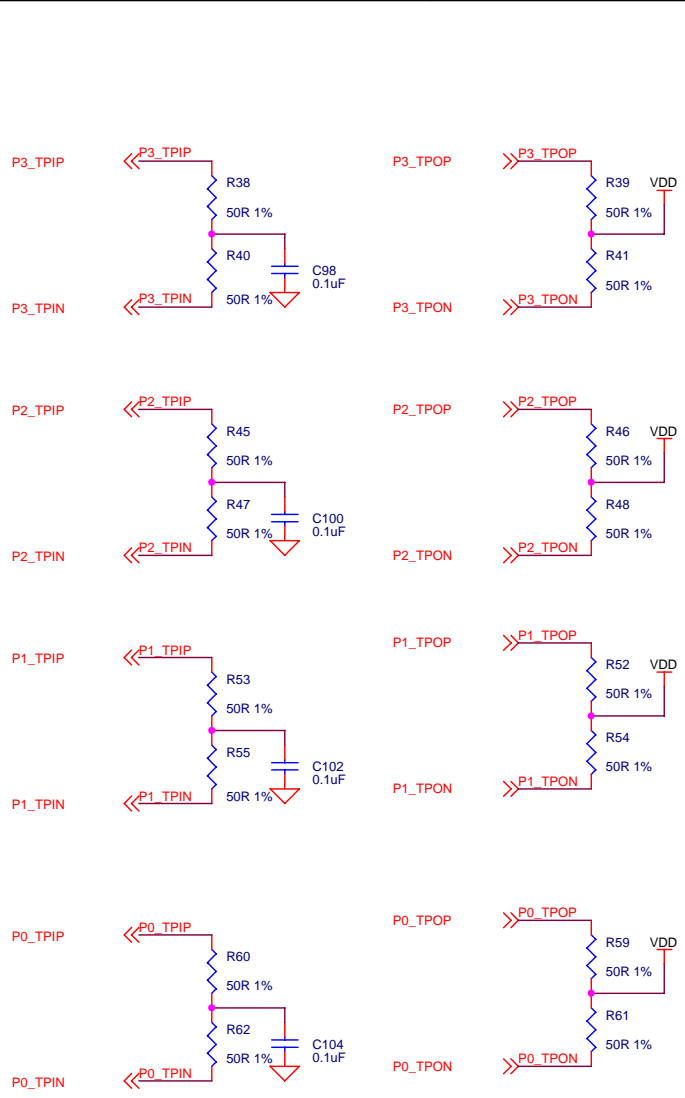

SHENZHEN KINGTECH ELECTRONICS CO.,LTD		
Title Trans and RJ45 for Port 0-3		
Size B	Document Number TP-LINK 82224	Rev 1.1
Date: Tuesday, June 26, 2001	Sheet 5	of 20

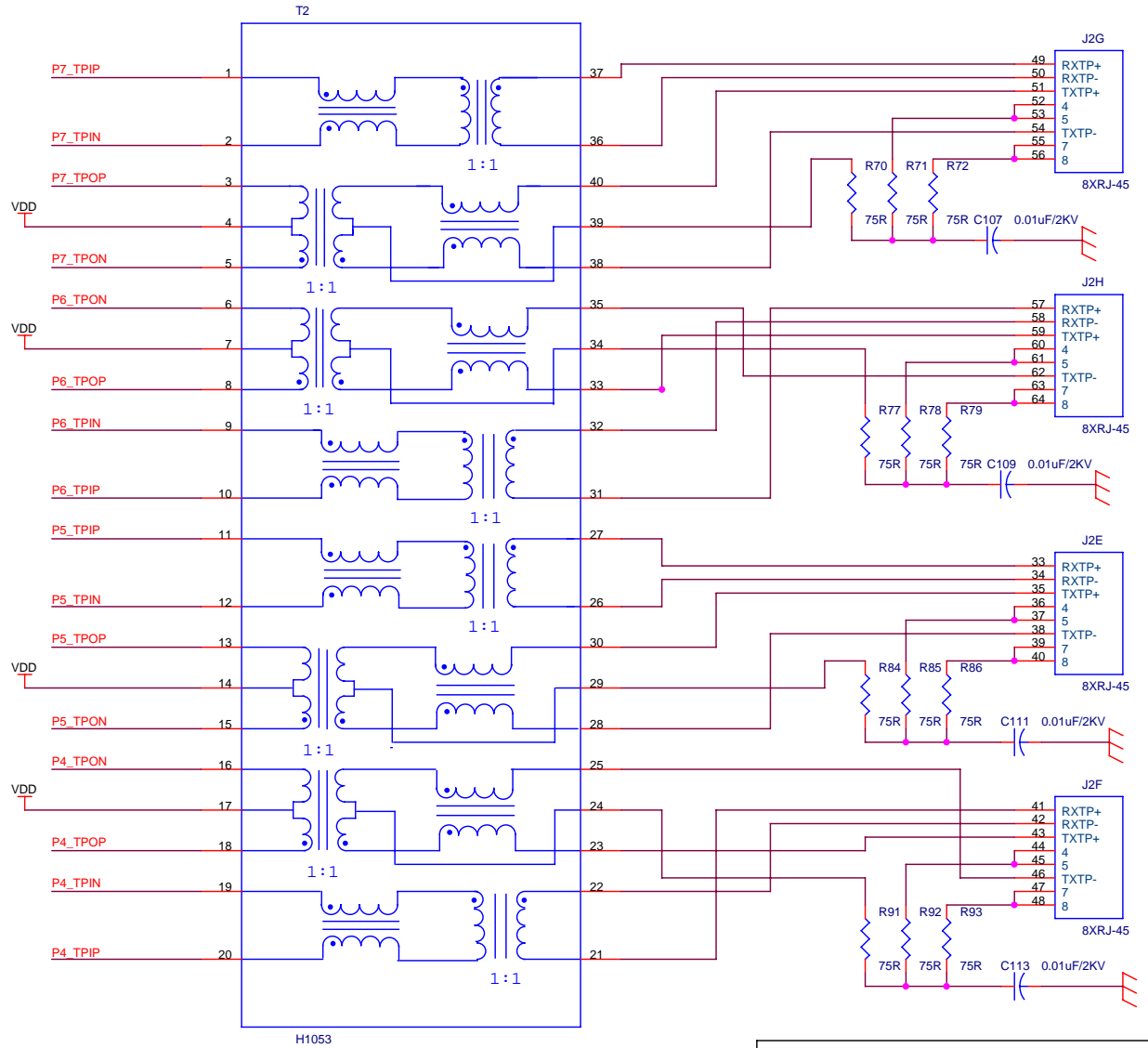
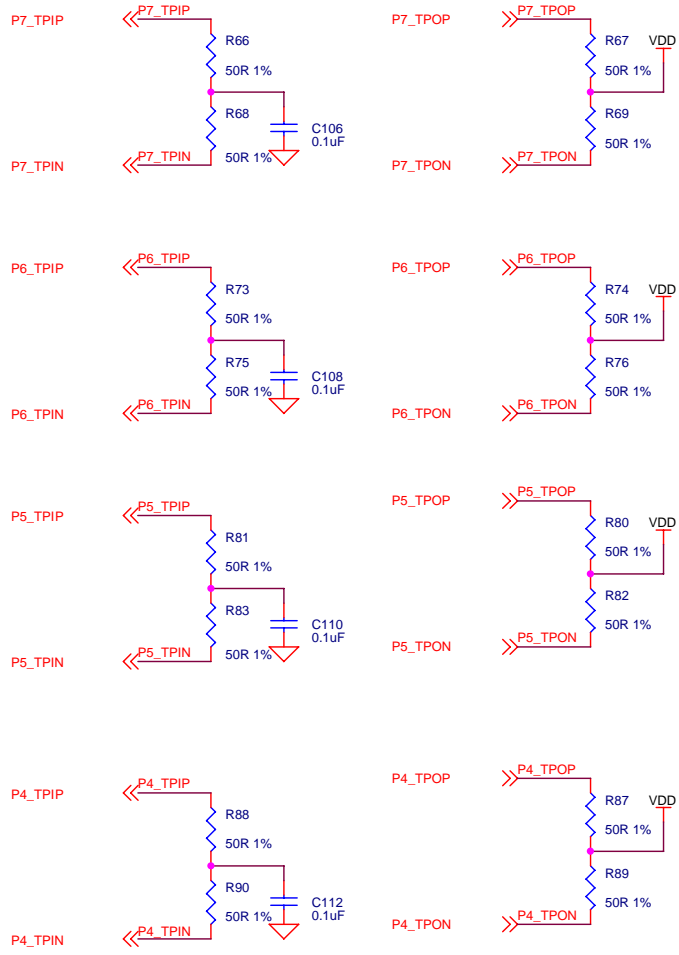

SHENZHEN KINGTECH ELECTRONICS CO.,LTD		
Title Trans and RJ45 for Port 4-7		
Size B	Document Number TP-LINK 82224	Rev 1.1
Date: Tuesday, June 26, 2001	Sheet 6	of 20

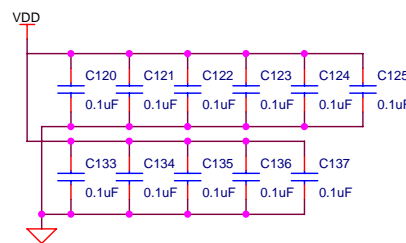
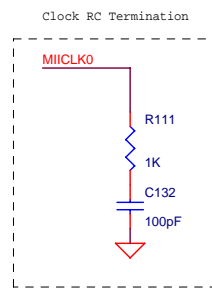
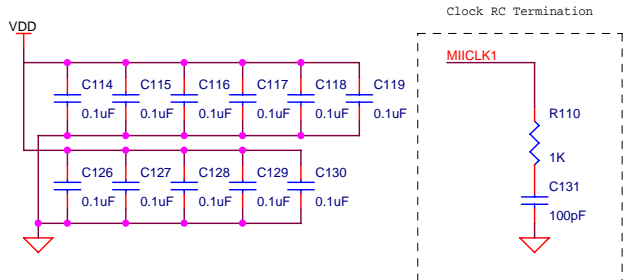
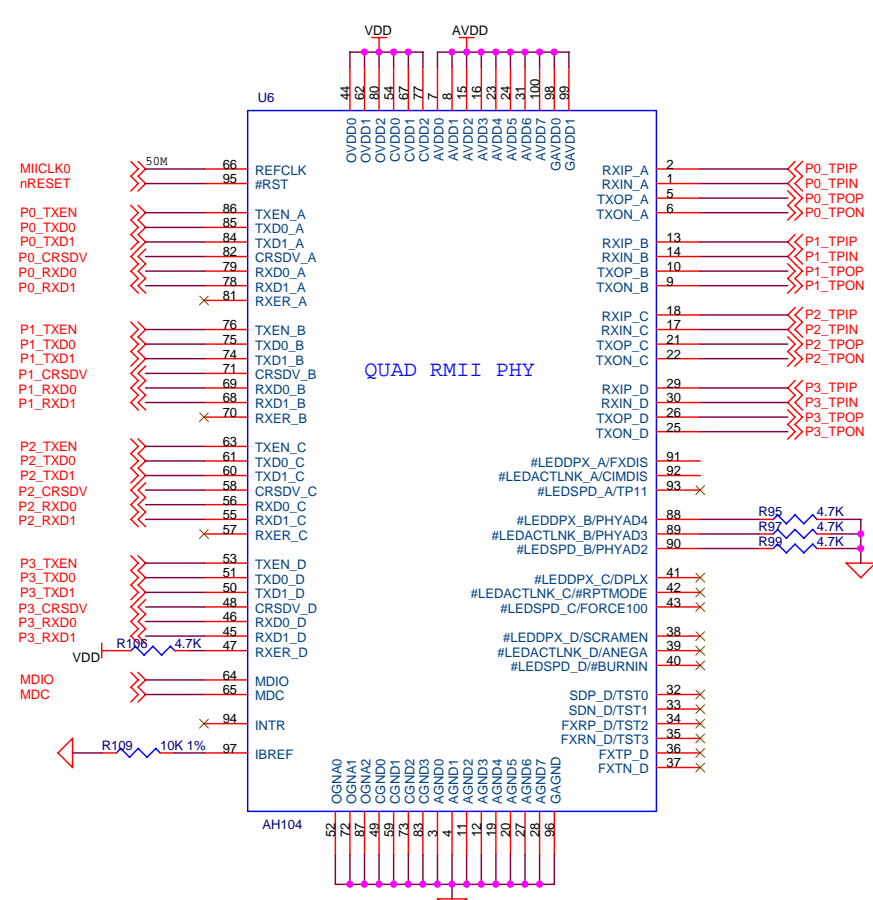
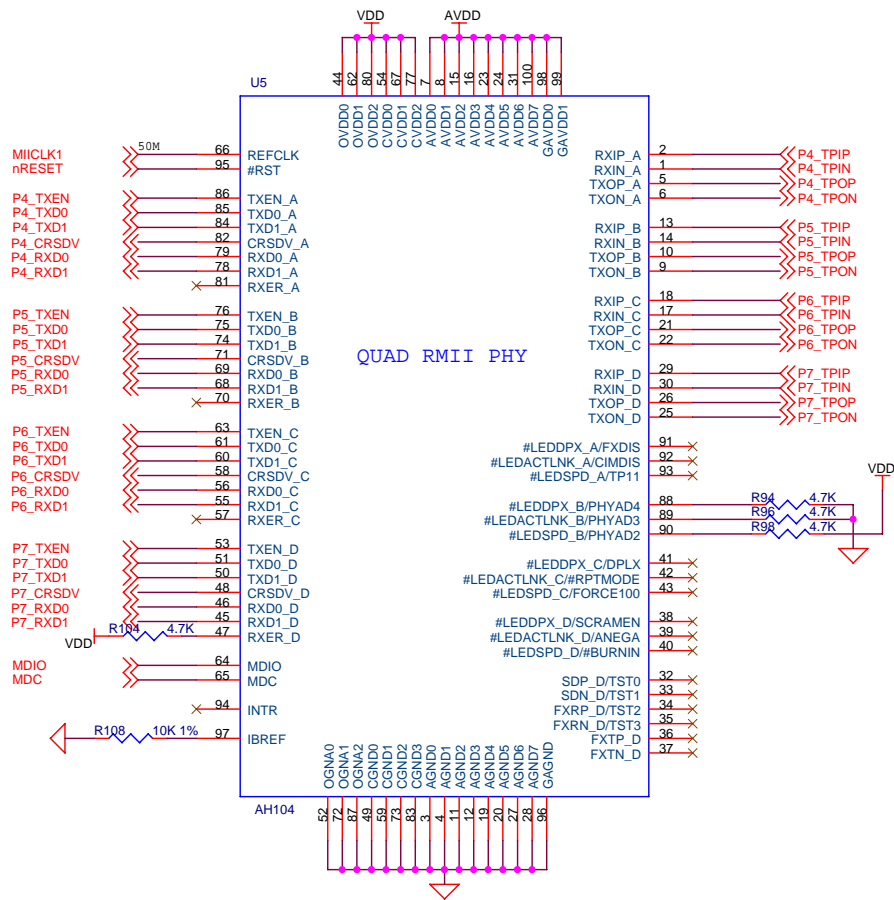

SHENZHEN KINGTECH ELECTRONICS CO.,LTD		
Title RMII PHY for Port 0-7		
Size B	Document Number TP-LINK 82224	Rev 1.1
Date: Tuesday, June 26, 2001	Sheet 7	of 20

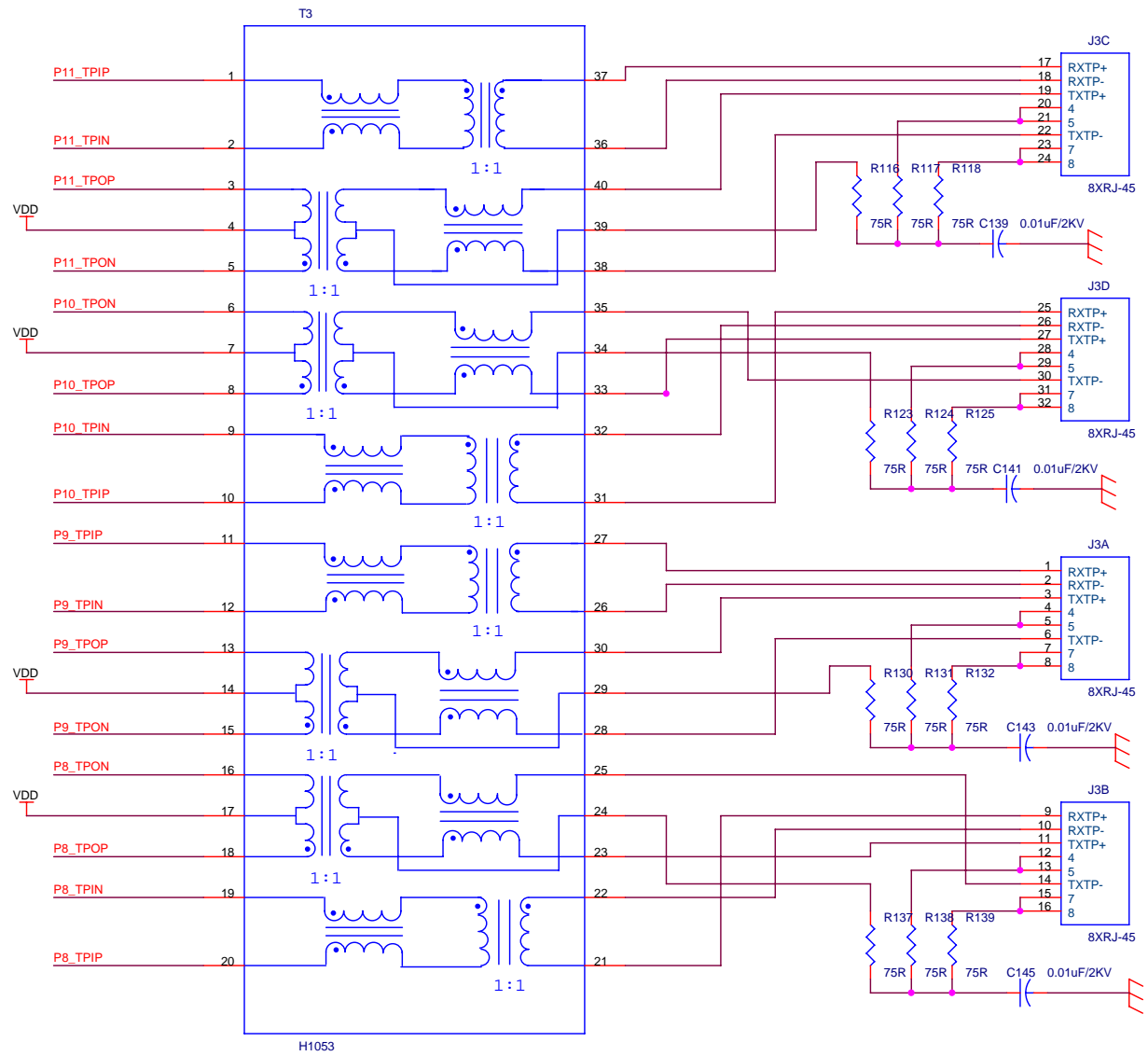
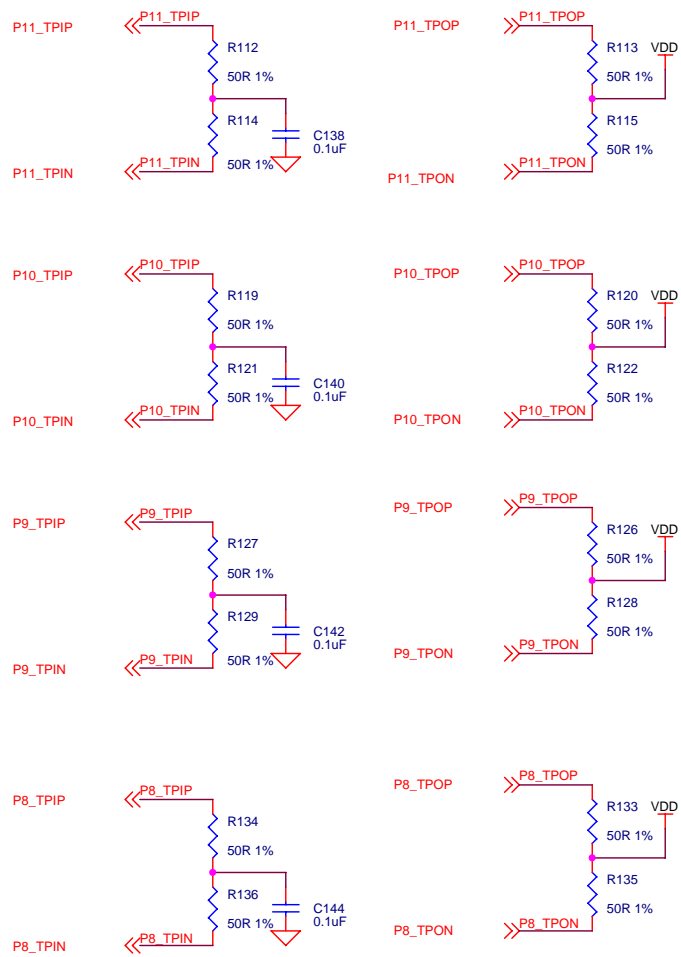

SHENZHEN KINGTECH ELECTRONICS CO.,LTD		
Title Trans and RJ45 for Port 8-11		
Size B	Document Number TP-LINK 82224	Rev 1.1
Date: Tuesday, June 26, 2001	Sheet 8	of 20

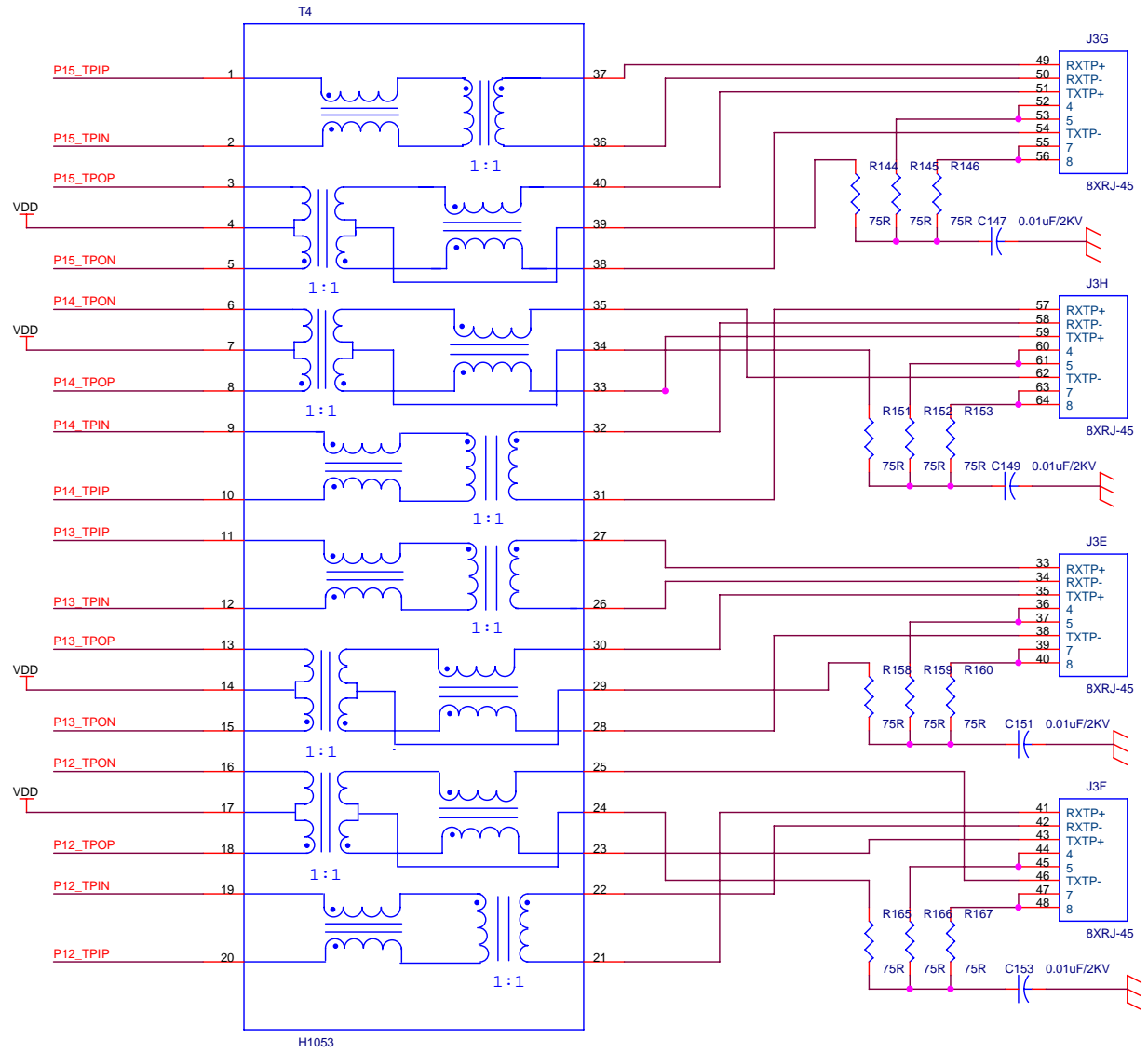
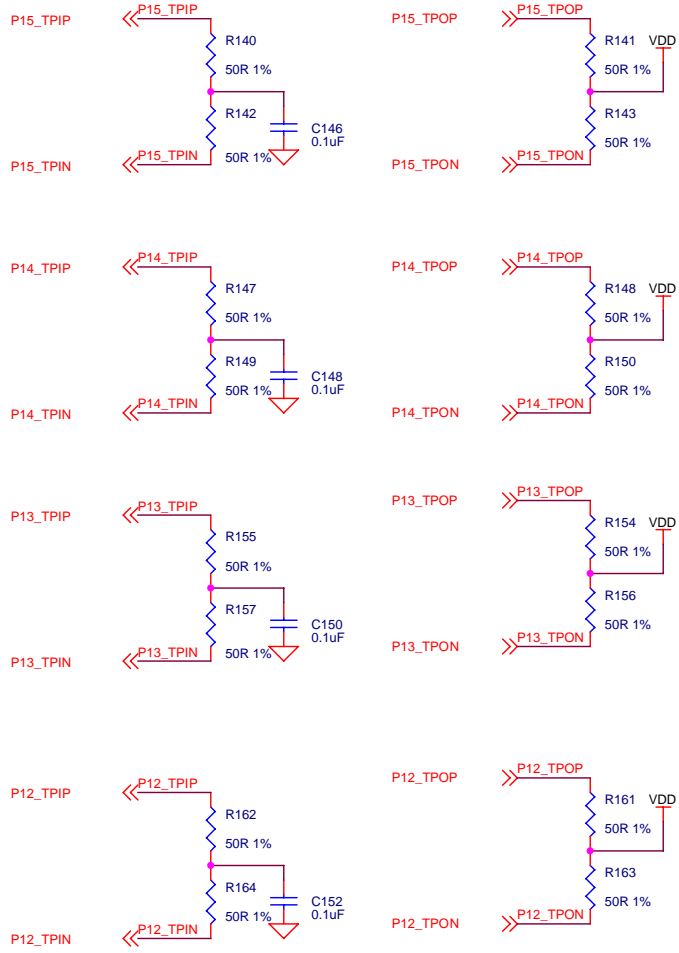

SHENZHEN KINGTECH ELECTRONICS CO.,LTD		
Title Trans and RJ45 for Port 12-15		
Size B	Document Number TP-LINK 82224	Rev 1.1
Date: Tuesday, June 26, 2001	Sheet 9	of 20

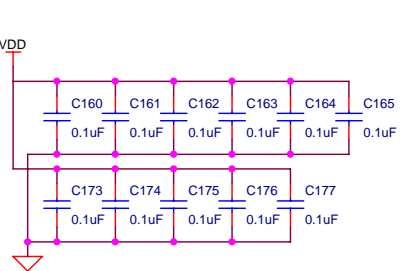
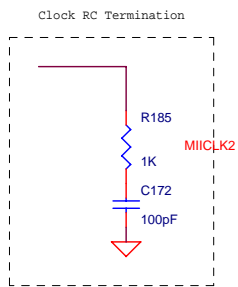
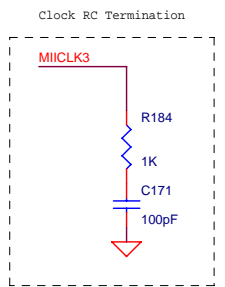
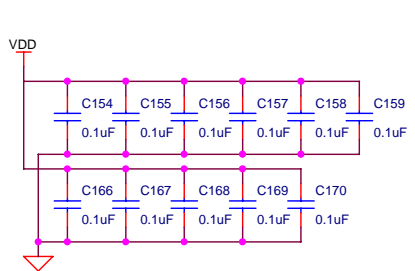
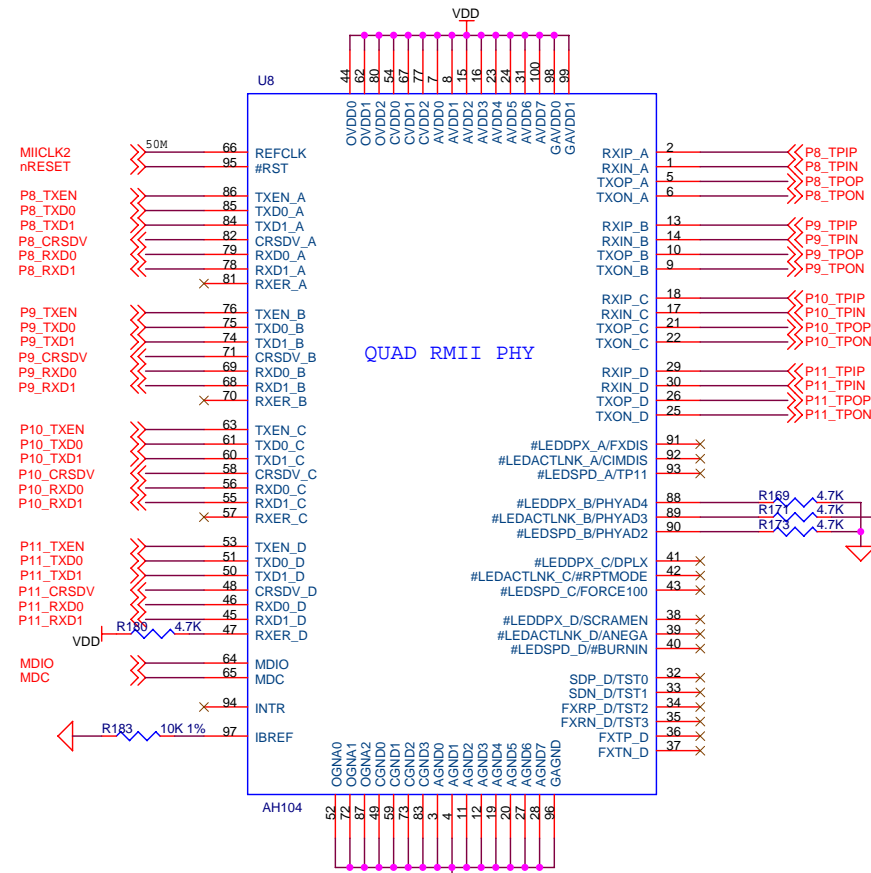
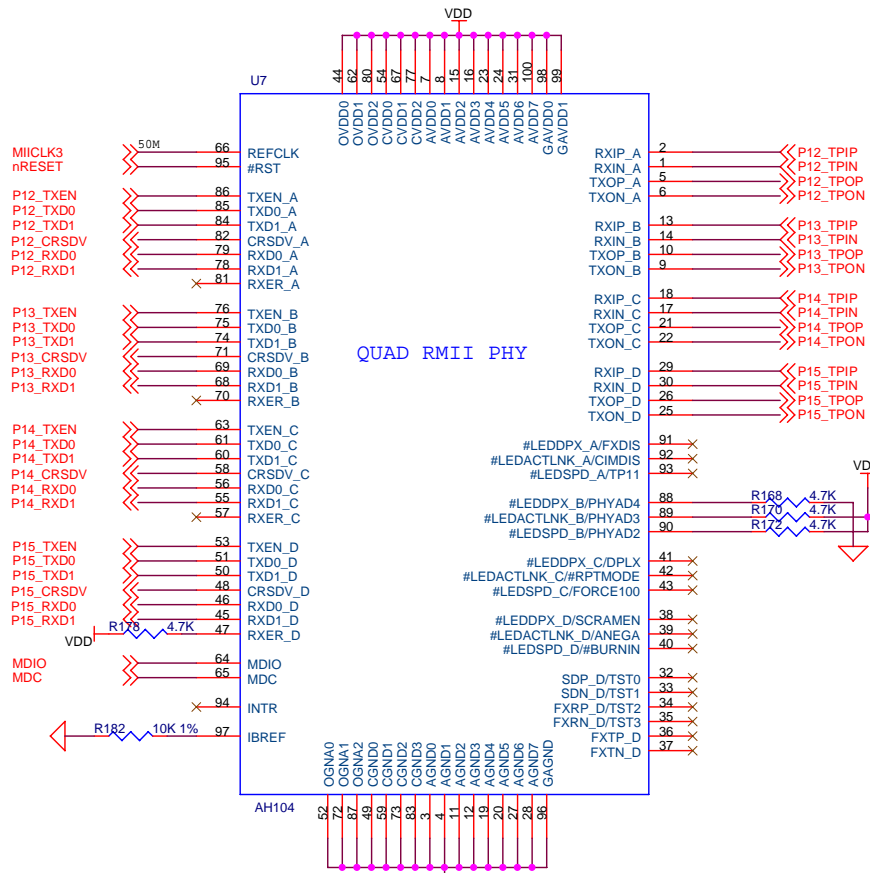

SHENZHEN KINGTECH ELECTRONICS CO.,LTD		
Title	RMII PHY for Port 8-15	
Size	Document Number	Rev
B	TP-LINK 82224	1.1
Date:	Tuesday, June 26, 2001	Sheet 10 of 20

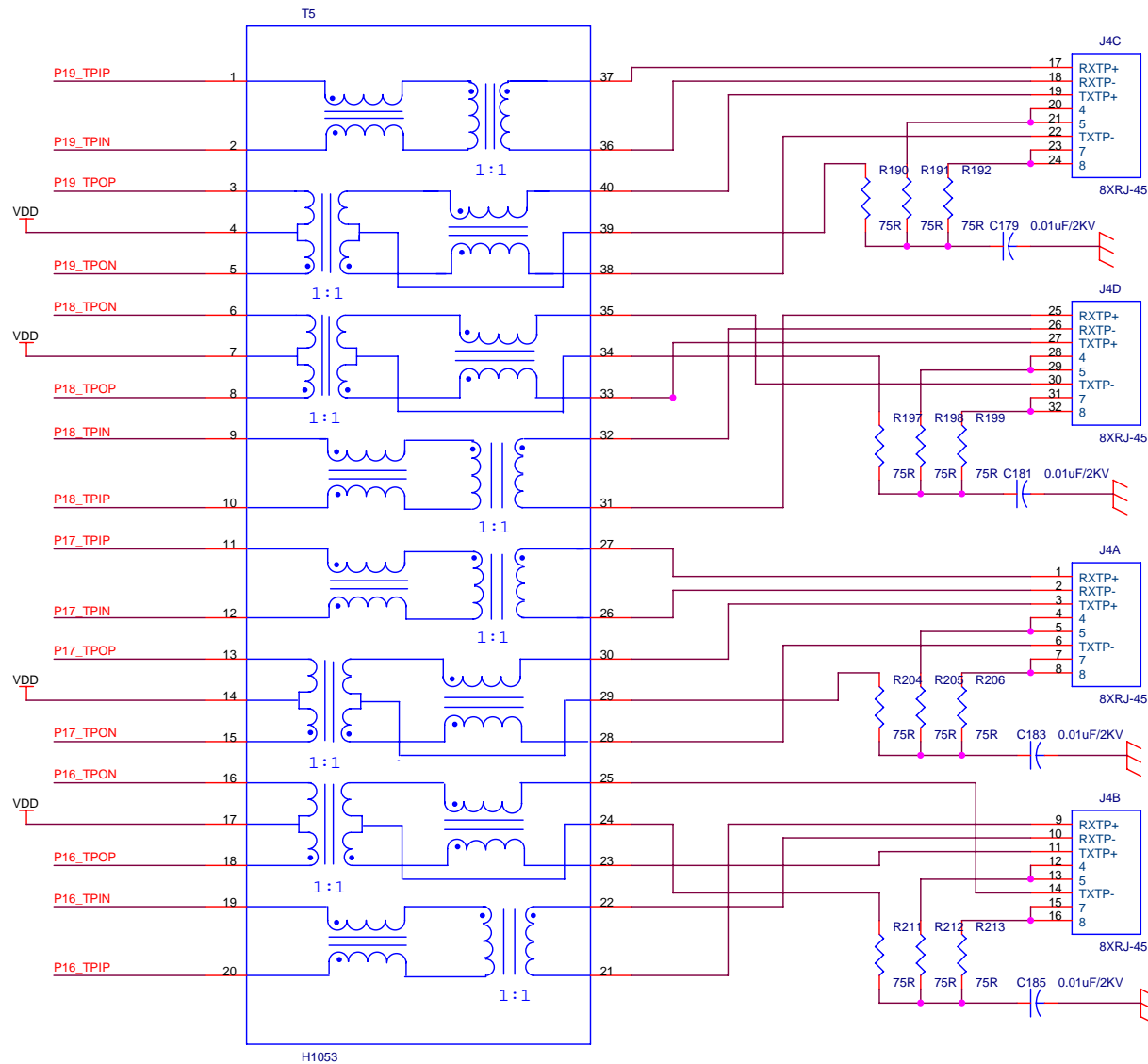
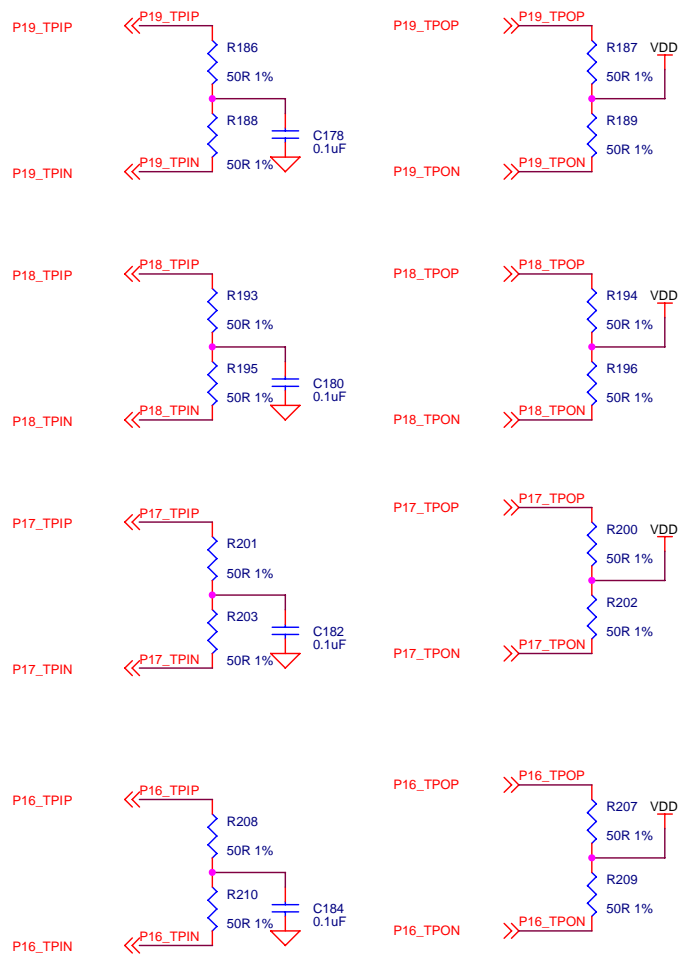

SHENZHEN KINGTECH ELECTRONICS CO.,LTD		
Title	Trans and RJ45 for Port 16-19	
Size	Document Number	Rev
B	TP-LINK 82224	1.1
Date:	Tuesday, June 26, 2001	Sheet 11 of 20

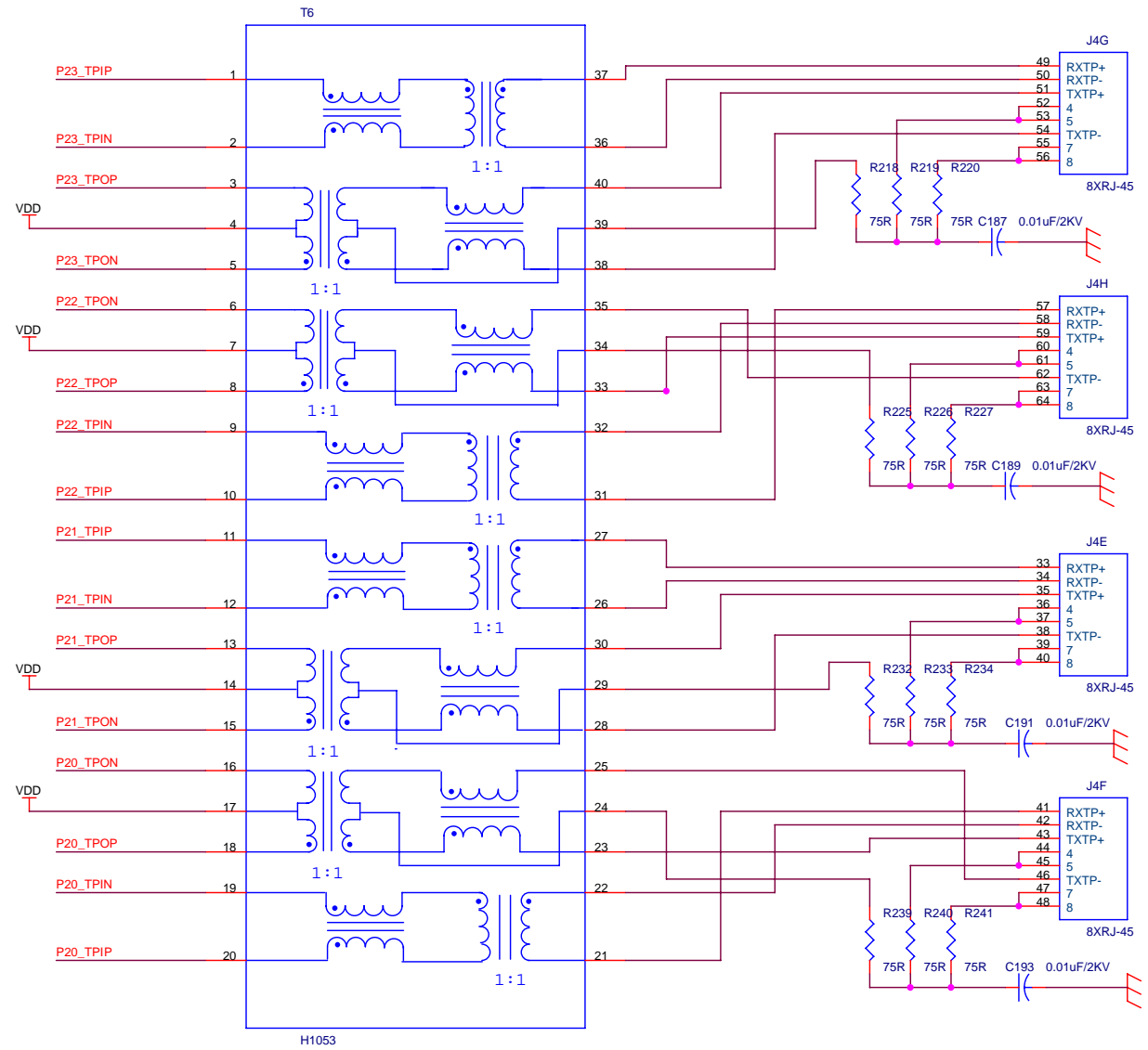
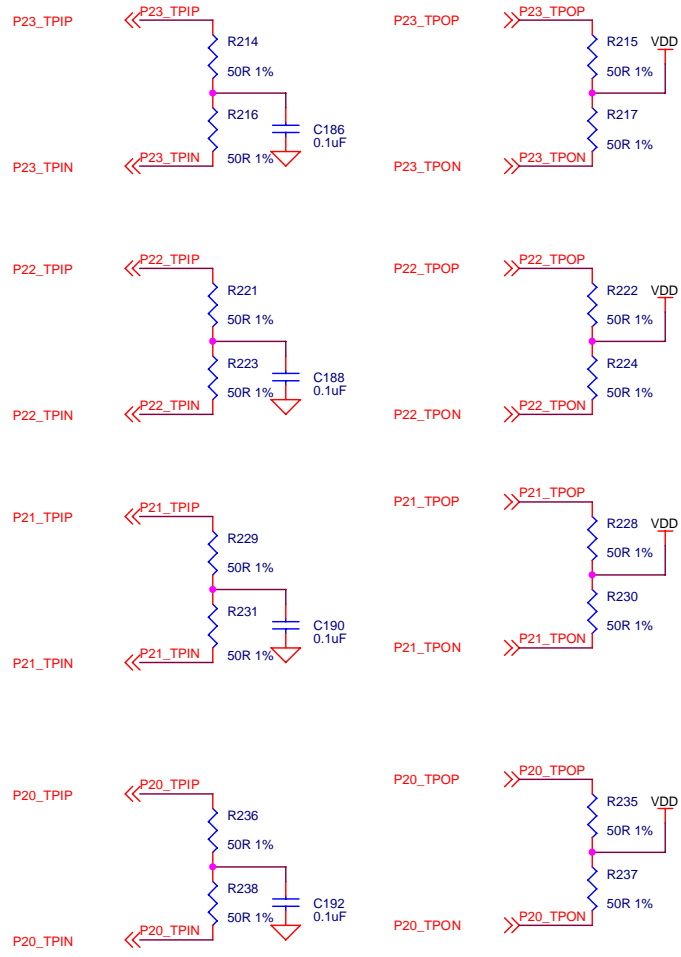

SHENZHEN KINGTECH ELECTRONICS CO.,LTD		
Title Trans and RJ45 for Port 20-23		
Size B	Document Number TP-LINK 82224	Rev 1.1
Date: Tuesday, June 26, 2001	Sheet 12	of 20

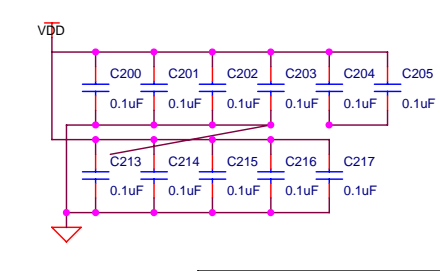
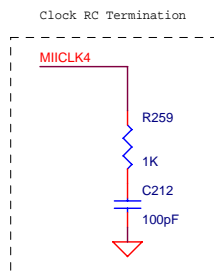
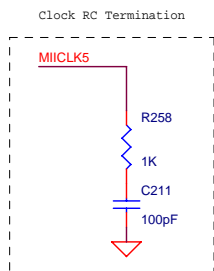
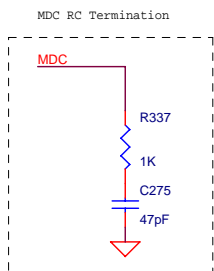
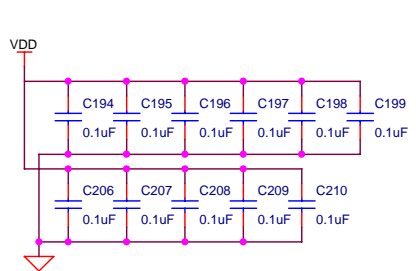
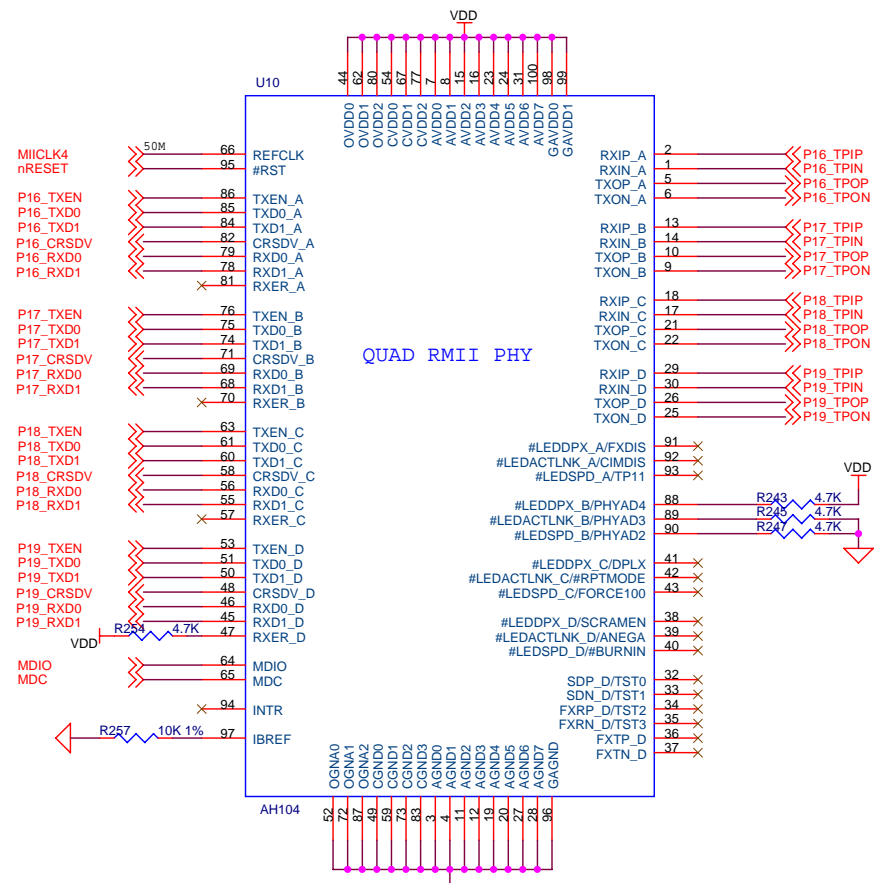
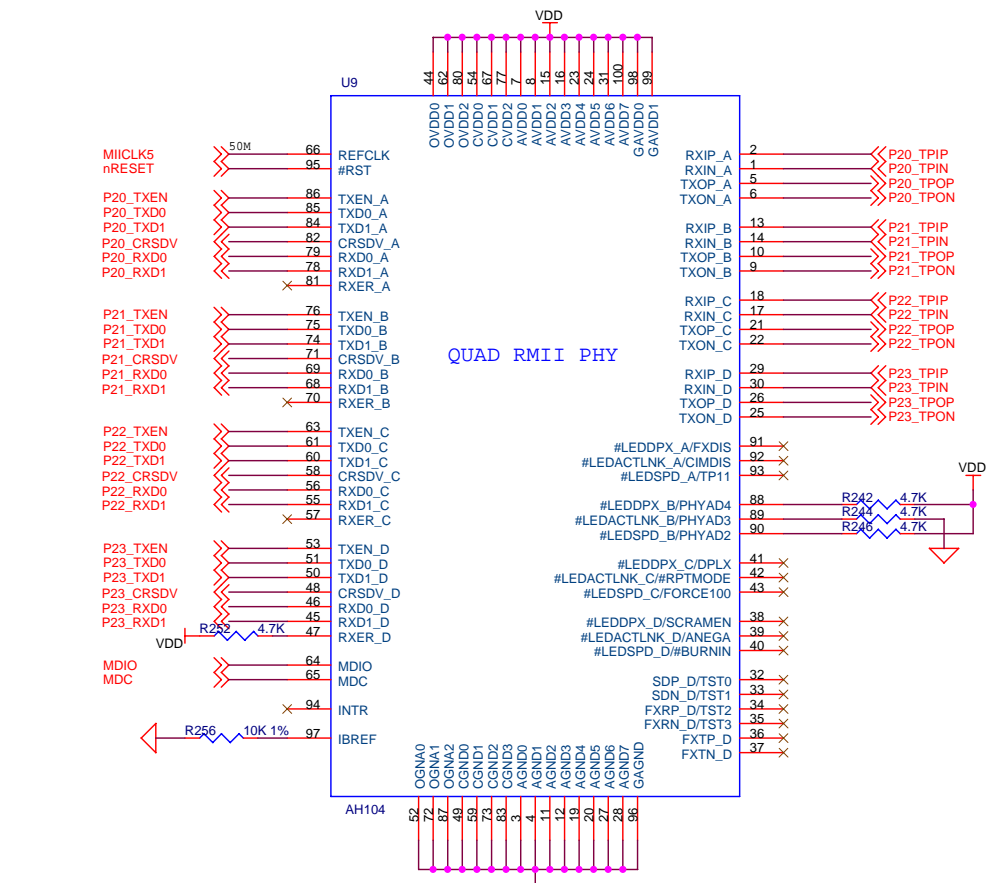

SHENZHEN KINGTECH ELECTRONICS CO.,LTD		
Title RMII PHY for Port 16-23		
Size B	Document Number TP-LINK 82224	Rev 1.1
Date: Tuesday, June 26, 2001	Sheet 13	of 20

P21_TXD1
P21_TXD0
P20_TXD1
P20_TXD0
P18_TXD1
P18_TXD0
P17_TXD1
P17_TXD0
P21_TXEN
P20_TXEN
P17_TXEN
P18_TXEN
LEDCLK
LEDVLD0
LEDVLD1
nLED3
nLED2
nLED1
nLED0
P15_TXEN
P14_TXEN
P12_TXEN
P23_TXEN
P11_TXEN
P23_TXD3
P23_TXD2
P23_TXD1
P23_TXD0
P9_TXEN
P8_TXEN
P6_TXEN
P5_TXEN
P2_TXEN
P0_TXEN
P3_TXEN
P5_TXD0
P5_TXD1
P3_TXD0
P3_TXD1
P2_TXD0
P2_TXD1
P0_TXD0
P0_TXD1

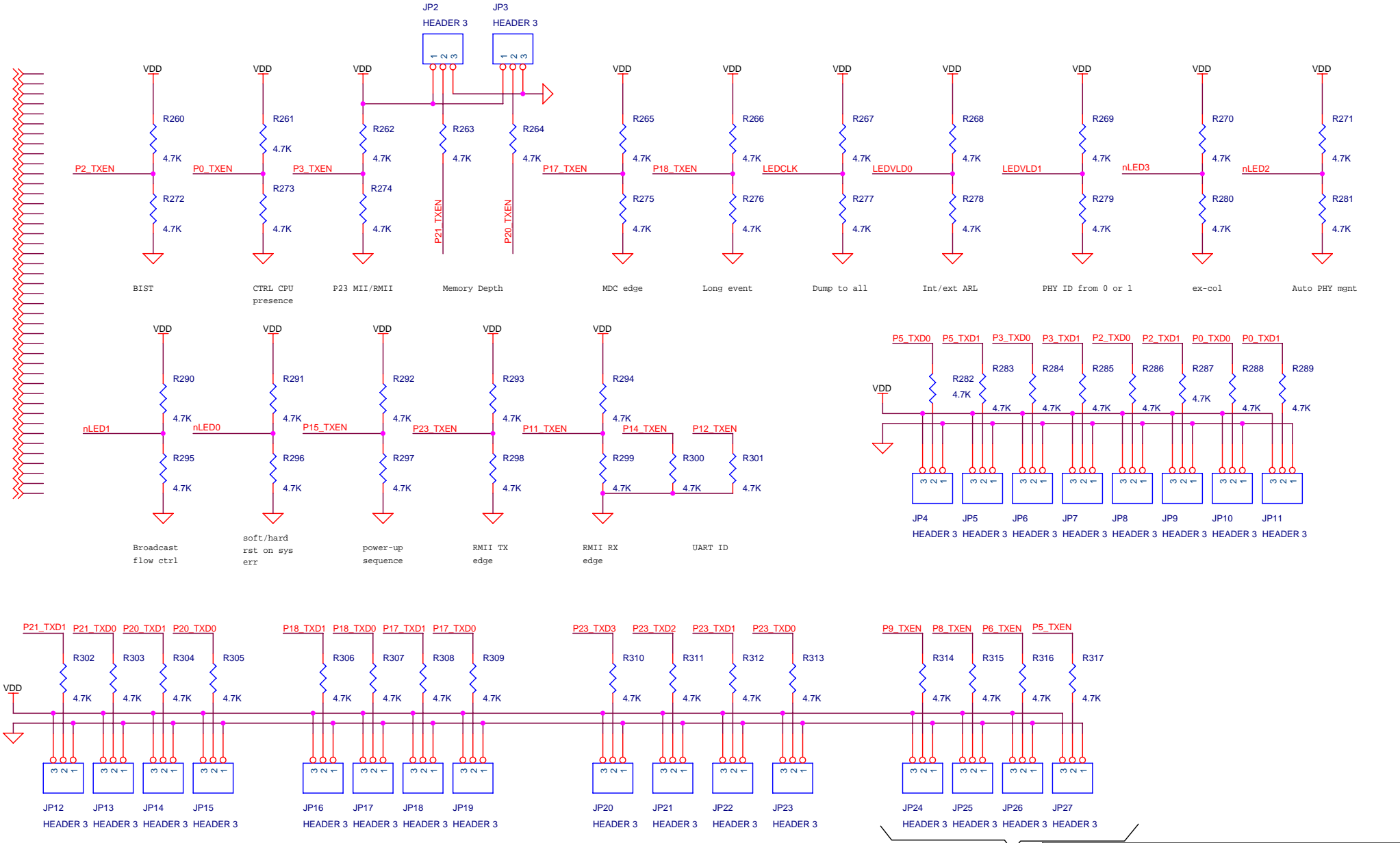

SHENZHEN KINGTECH ELECTRONICS CO.,LTD		
Title	Power-On-Setting(Switch)	
Size	Document Number	Rev
B	TP-LINK 82224	1.1
Date:	Tuesday, June 26, 2001	Sheet 14 of 20

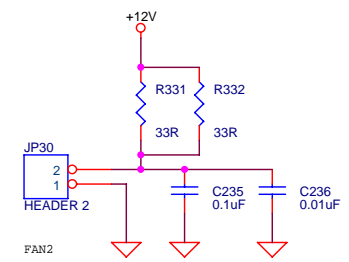
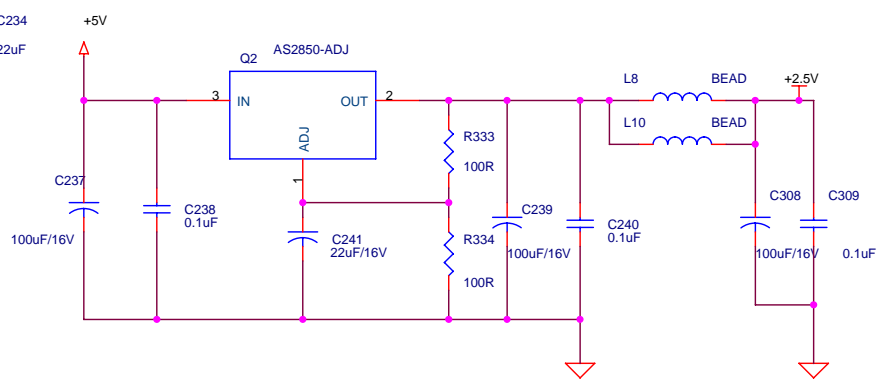
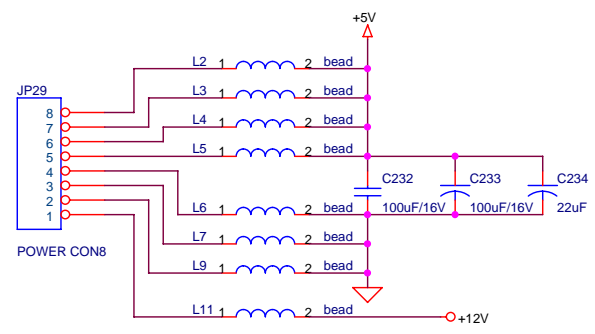
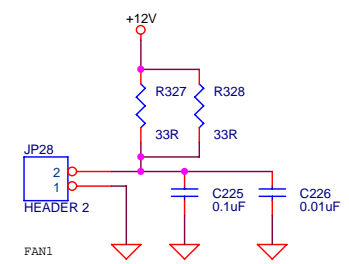
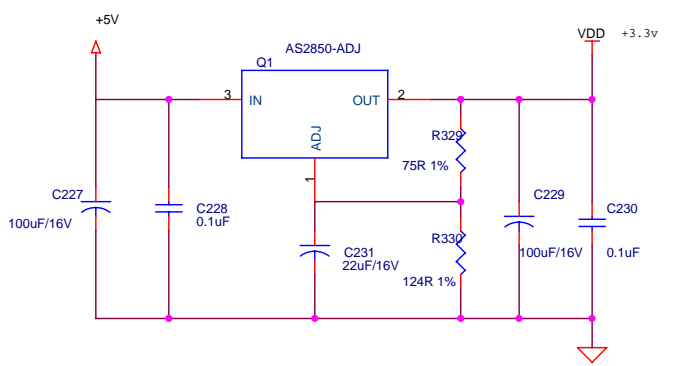
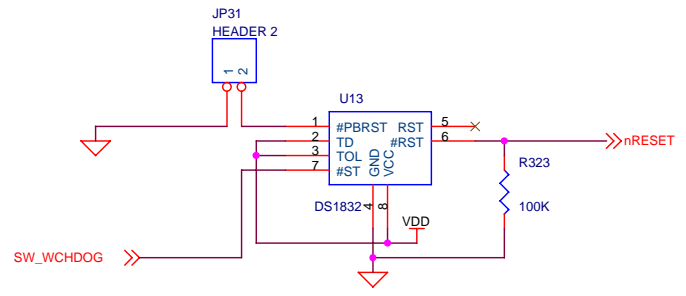
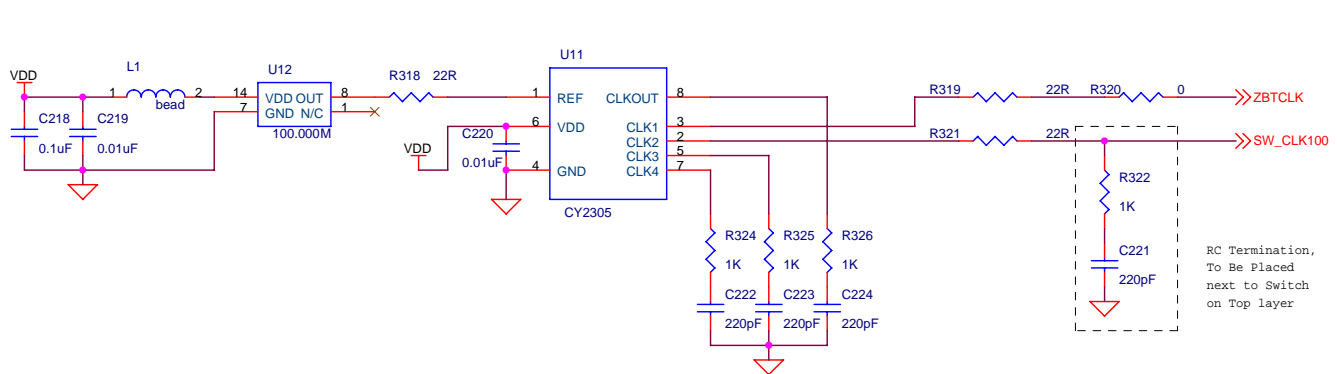

SHENZHEN KINGTECH ELECTRONICS CO.,LTD		
Title	Power ,Colck and Reset	
Size B	Document Number TP-LINK 82224	Rev 1.1
Date:	Tuesday, June 26, 2001	Sheet 15 of 20

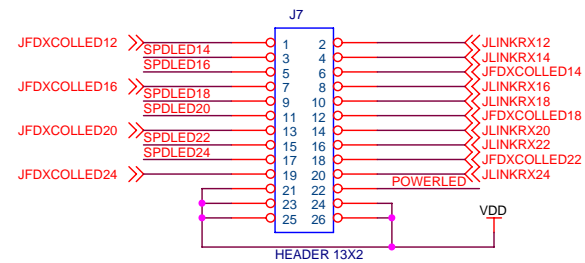
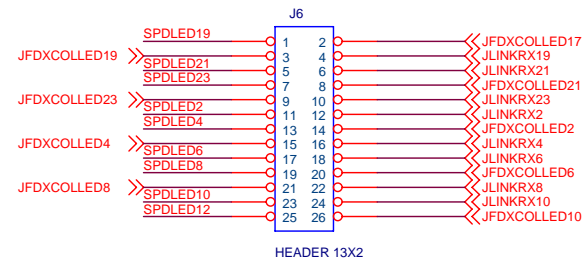
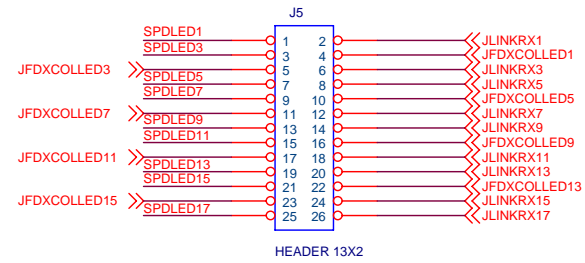
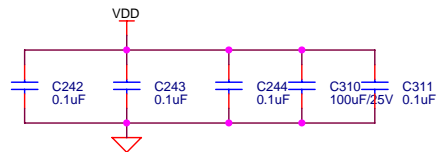
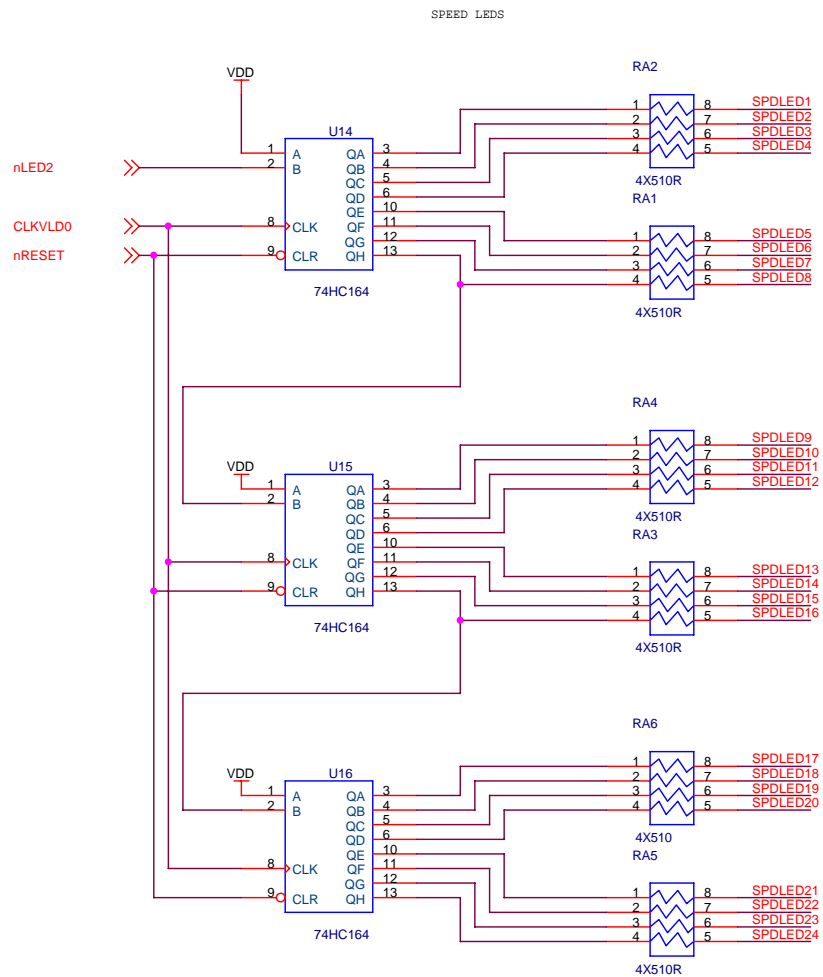

SHENZHEN KINGTECH ELECTRONICS CO.,LTD		
Title	Power &Speed-LEDS and Connector	
Size	Document Number	Rev
B	TP-LINK 82224	1.1
Date:	Tuesday, June 26, 2001	Sheet 16 of 20

Full-Duplex LEDS

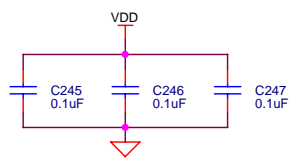
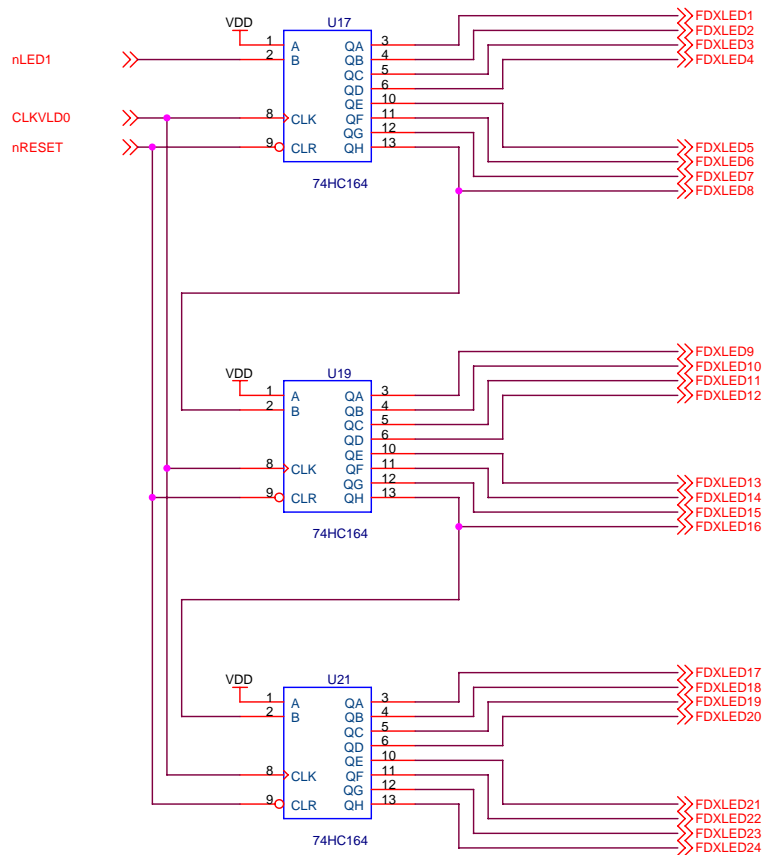

Collision LEDS

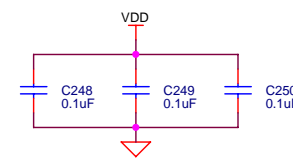
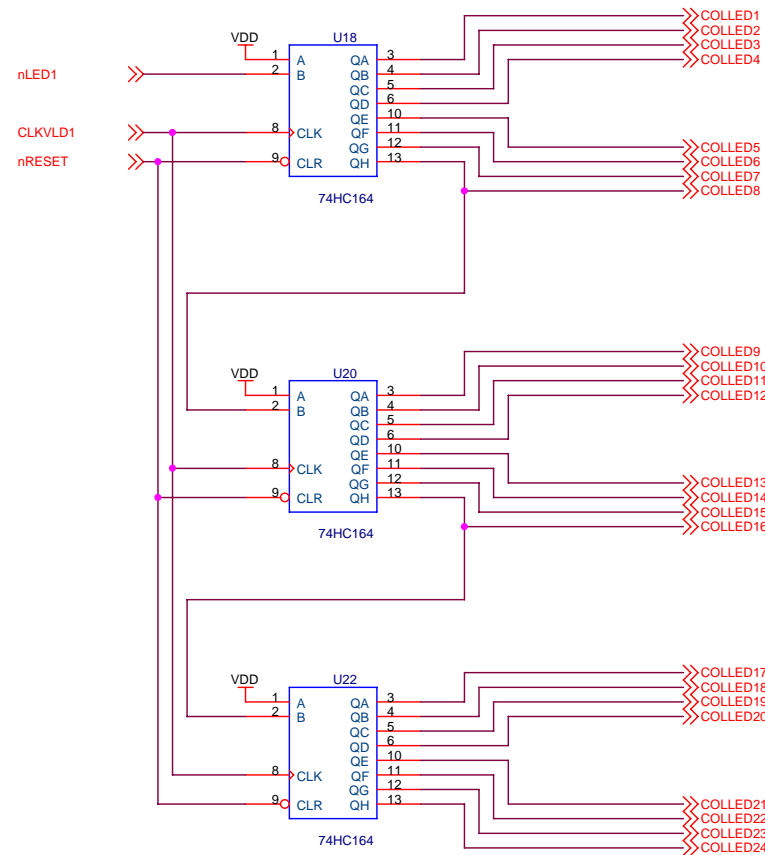

SHENZHEN KINGTECH ELECTRONICS CO.,LTD		
Title Full-duplex and Collision LEDs		
Size B	Document Number TP-LINK 82224	Rev 1.1
Date: Tuesday, June 26, 2001	Sheet 17	of 20

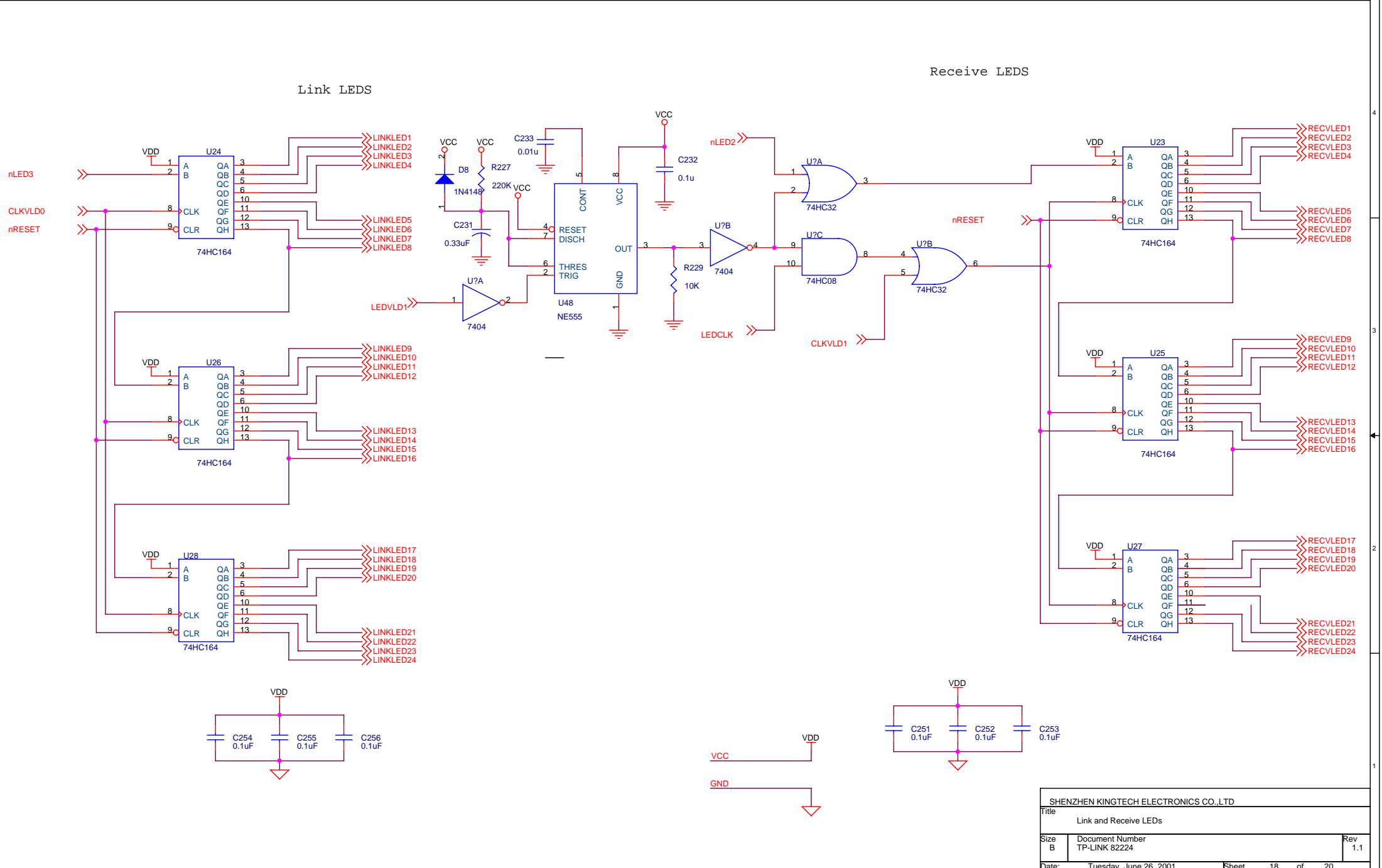

SHENZHEN KINGTECH ELECTRONICS CO.,LTD		
Title Link and Receive LEDs		
Size B	Document Number TP-LINK 82224	Rev 1.1
Date:	Tuesday, June 26, 2001	Sheet 18 of 20

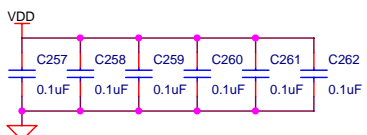
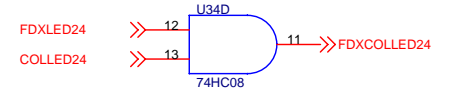
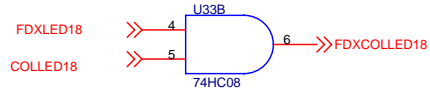
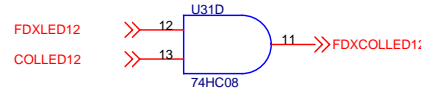
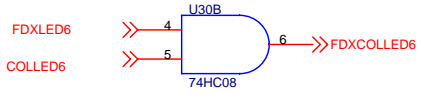
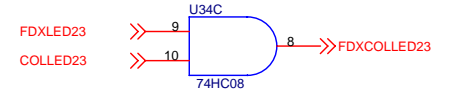
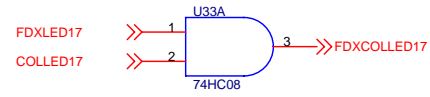
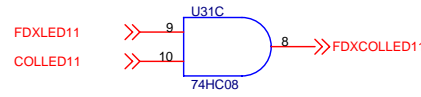
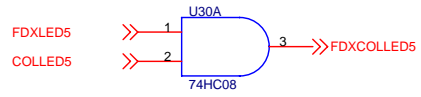
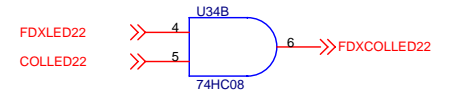
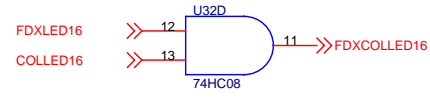
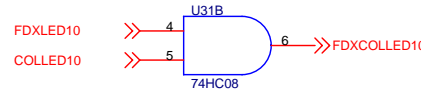
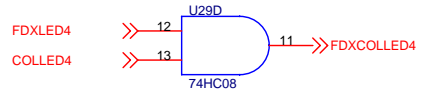
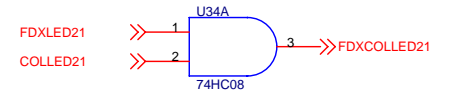
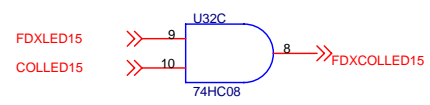
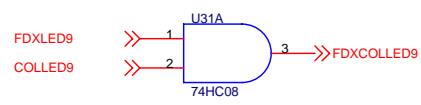
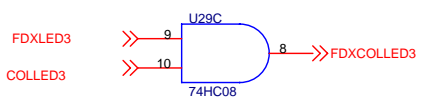
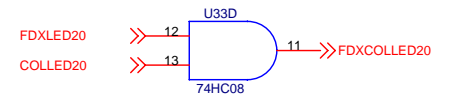
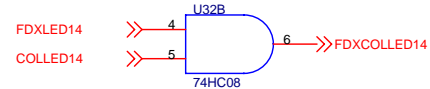
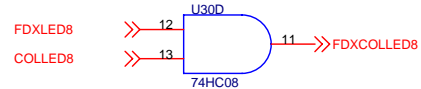
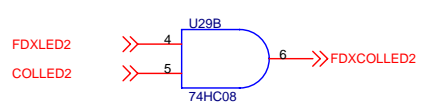
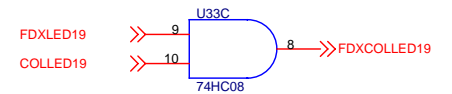
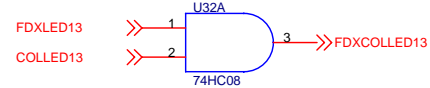
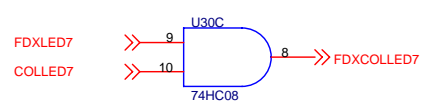
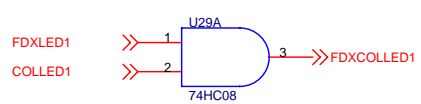

SHENZHEN KINGTECH ELECTRONICS CO.,LTD		
Title Fdxled and Collisionled con		
Size B	Document Number TP-LINK 82224	Rev 1.1
Date: Tuesday, June 26, 2001	Sheet 19	of 20

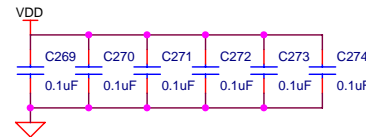
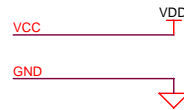
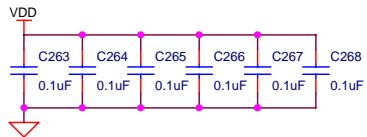
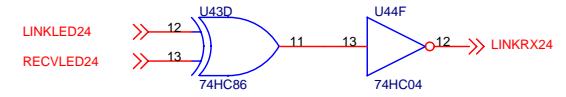
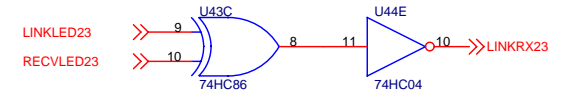
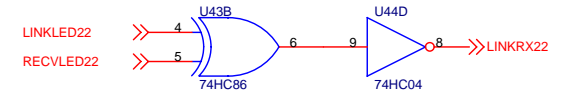
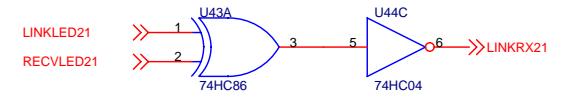
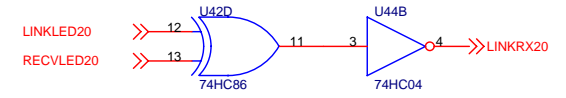
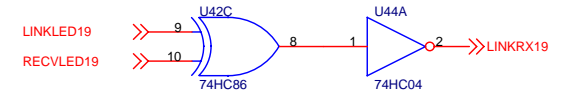
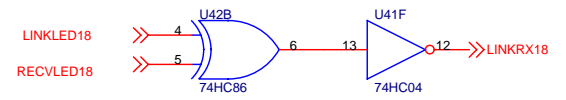
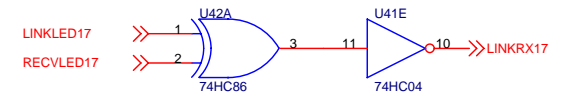
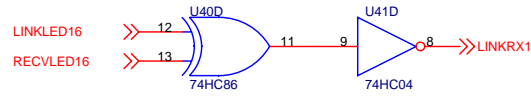
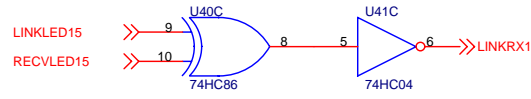
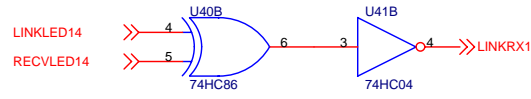
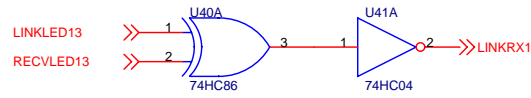
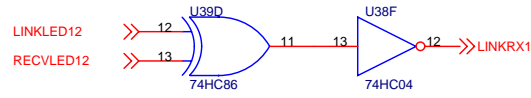
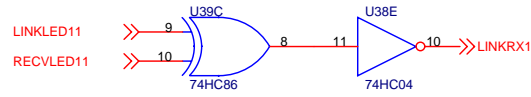
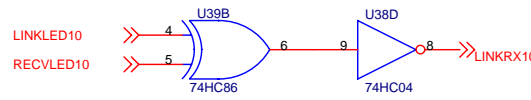
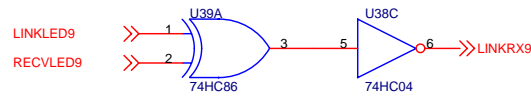
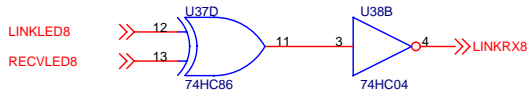
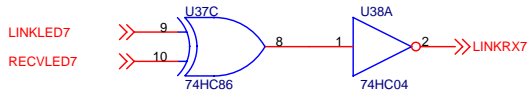
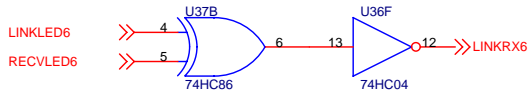
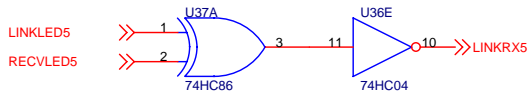
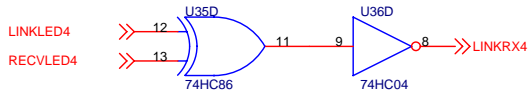
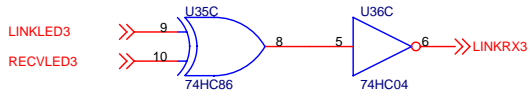
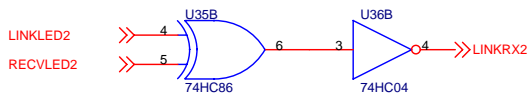
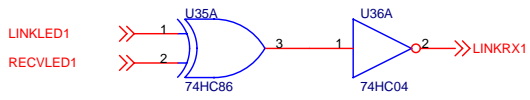

SHENZHEN KINGTECH ELECTRONICS CO.,LTD		
Title Linkled and Receiveled con		
Size B	Document Number TP-LINK 82224	Rev 1.1
Date:	Tuesday, June 26, 2001	Sheet 20 of 22

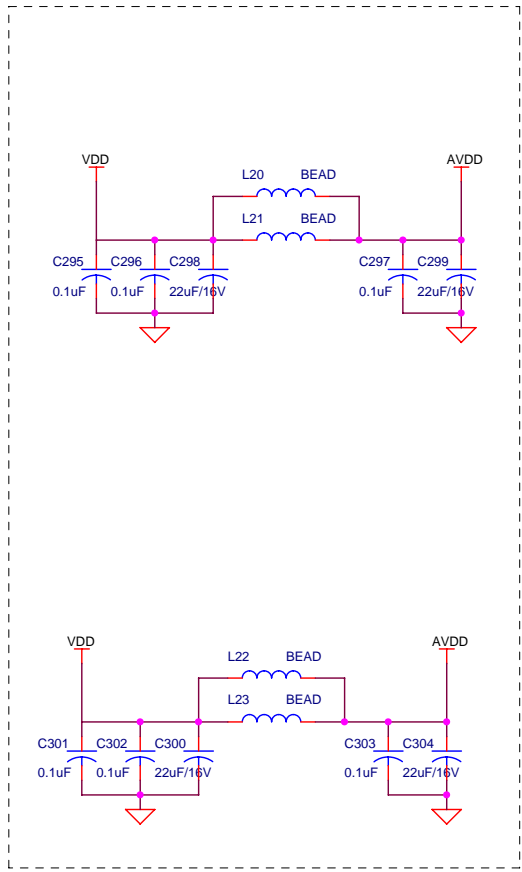

U5, U6

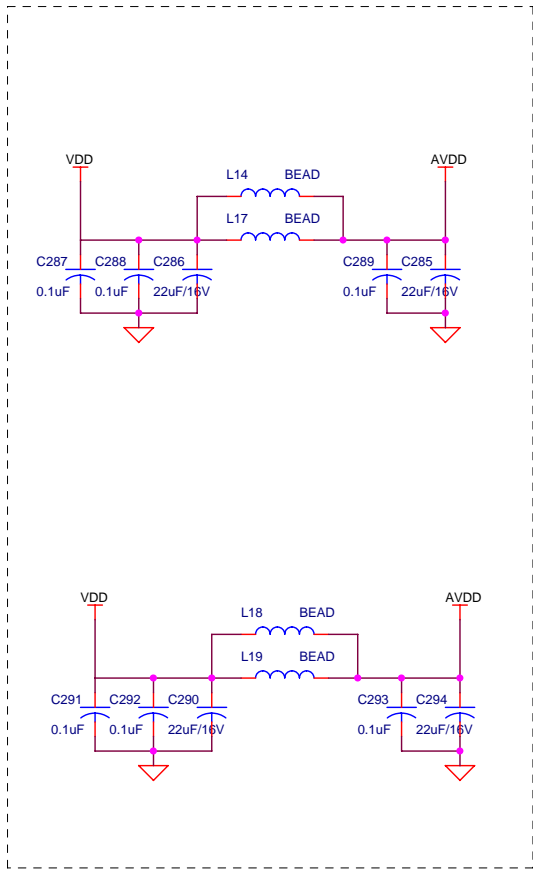

U7, U8

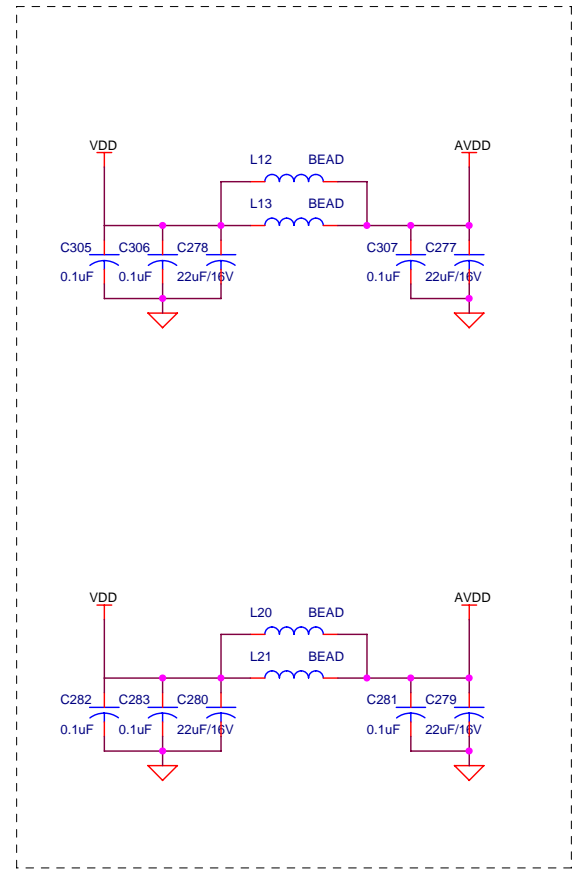

U9, U10

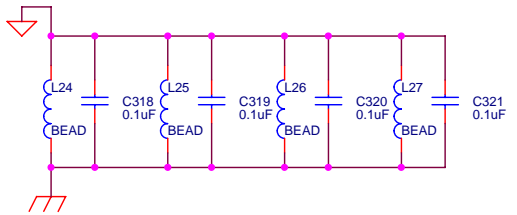

SHENZHEN KINGTECH ELECTRONICS CO.,LTD		
Title VDD-AVDD		
Size B	Document Number TP-LINK 82224	Rev 1.1
Date: Tuesday, June 26, 2001	Sheet 21	of 22

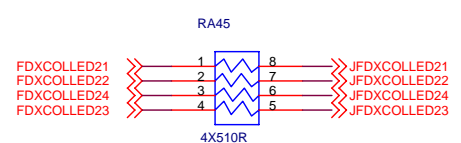
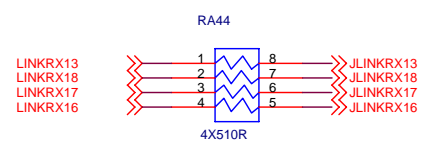
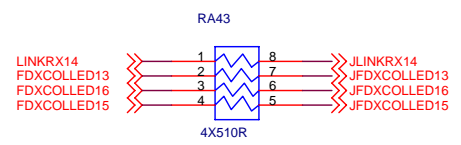
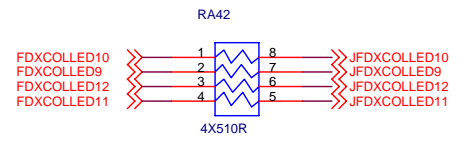
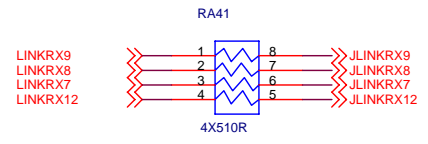
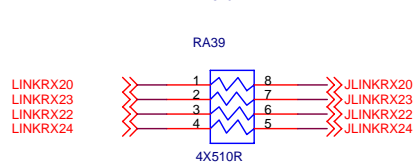
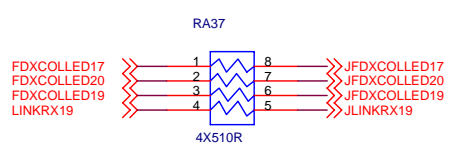
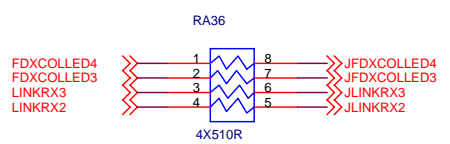
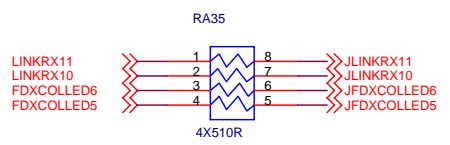
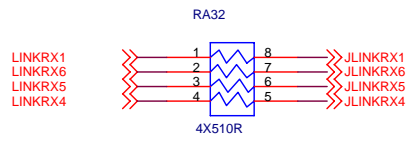
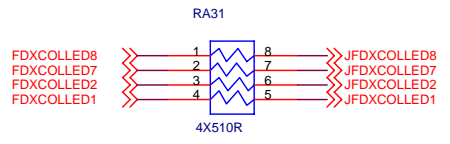

SHENZHEN KINGTECH ELECTRONICS CO.,LTD		
Title RA		
Size B	Document Number TP-LINK ACD82224	Rev 1.1
Date: Tuesday, June 26, 2001	Sheet 22 of 22	