

High Voltage Off-Line Linear Regulator

by James Lei, Applications Engineering Manager

Introduction

There are many applications for small, linear voltage regulators that operate from high input voltages. They are ideally suited for powering CMOS ICs, small analog circuits, and other loads requiring low current. These circuits can be used in several applications requiring power directly from the utility line. They can also be used for applications which either have very wide input voltage variations or environments with high voltage spikes; for example, telecommunications, automotive, and avionics. This application note discusses several circuits which will benefit these applications.

Direct off-line applications require operation at 120VAC to 240VAC which corresponds to maximum peak voltages of $\pm 340V$. Applications in telecommunications, automotive, and avionics require immunity against very fast, high voltage transients. In telecommunications, the high voltage transients are caused by lightning or spurious radiations. In automotive and avionics they are caused by inductive loads such as ignition coils and electrical motors. International Standards Organization specification ISO/TR7637, for electrical interference by conduction and coupling in automobiles, shows that transients up to $-300V$ and $+120V$ can be generated due to various inductive loads.

In addition to the ability to withstand high voltages, many circuits used for the above mentioned applications also require low quiescent current. The low quiescent current is required to minimize power dissipation in these linear regulators. Many telecommunication applications require very low quiescent current because there are limitations to the allowable current that can be drawn from the telephone lines. Automotive and avionics applications require low quiescent current

to minimize the loading on batteries, especially when the vehicles are not in use for long periods of time. For example, only a few microamperes are needed for powering memory ICs. In such situations the quiescent current of the regulator should be within a few microamperes.

The high voltage protected, 5.0V linear regulator shown in Figure 1 meets all of the above requirements. It is very simple, compact and inexpensive. The high operating voltage and high transient voltage protection are achieved by using Supertex part #LND150N8 in conjunction with a 5.0V linear regulator, Ricoh part #RH5RA50AA.

Circuit Description

The LND150N8 is a 500V, N-channel, depletion-mode MOSFET. It has a maximum $R_{DS(ON)}$ of $1.0K\Omega$, $V_{GS(OFF)}$ of -1.0 to $-3.0V$, and an I_{DSS} of 1.0 to $3.0mA$. The RH5RA50AA is a $5.0V \pm 2.5\%$ voltage regulator with a maximum quiescent current of $1.0\mu amp$. Both these parts are available in the SOT-89 (TO-243AA) surface mount package.

The high voltage input, HV_{IN} , is connected to the anode of diode D. The cathode of the diode is connected to the drain of the LND1. The diode is used as protection against negative transient voltages and as a half-wave rectifier for off-line application. The LND1 is connected in the source follower configuration, with its gate connected to the output, V_{OUT} , and its source to the input of the 5.0V regulator, V_{IN} . Capacitors C_1 , C_2 and C_3 are bypass capacitors. C_3 is required when HV_{IN} is negative, such as during the negative half cycle of an AC line, or negative transients. The proper value of C_3 is chosen based on the worst case duration and duty cycle of the negative pulses on HV_{IN} .

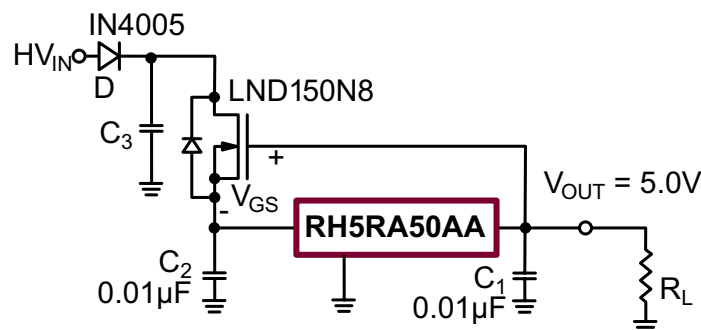

Figure 1: High Voltage Universal Off-Line Linear Regulator

HV_{IN} , V_{IN} and V_{OUT} are at 0V before a voltage is applied to HV_{IN} . The LND1 is turned on when its gate-to-source voltage, $V_{GS} = 0V$. Once a voltage is applied to HV_{IN} , current will flow through the diode and the “normally on” channel of the LND1 charging capacitor C_2 . The voltage across C_2 is connected to V_{IN} . As V_{IN} starts to increase, V_{OUT} will also continue to increase until it reaches its regulated voltage of 5.0V.

The LND1 is configured as a source follower with its gate connected to a fixed 5.0V value (nominal). The voltage on the source, V_{IN} , will follow the voltage on its gate, minus V_{GS} . $V_{IN} = V_{OUT} - V_{GS}$ where V_{GS} is the voltage required to supply the input current I_{IN} . If 500VDC is applied on HV_{IN} , V_{OUT} will remain at 5.0V and V_{IN} should be between 6.0 to 8.0V, since $V_{GS(OFF)}$ of LND150N8 is guaranteed to be -1.0 to -3.0V. The actual observed value was 6.26V.

The dropout voltage, $(V_{IN} - V_{OUT})$, for the 5.0V regulator with a 1.0mA load is rated as 30mV. To maintain regulation, V_{IN} must be equal to or greater than 5.03V. As I_{IN} increases, V_{IN} decreases and thereby increases the gate-to-source voltage on the LND1 to meet the I_{IN} requirement. The transfer characteristics of the LND1 give a good indication of V_{GS} vs. I_{IN} .

Advantages of the LND1

The important parameters of the LND1 are its 500V breakdown voltage, 1.5pF output capacitance and 1.0MΩ dynamic output impedance. Supertex utilizes a proprietary design and fabrication process to achieve very flat output characteristics which gives this device its very high dynamic impedance, r_o . The RH5RA50AA has an absolute maximum input voltage rating of 13.5V. The highbreakdown voltage of the LND1 extends the maximum input operating voltage range from 13.5V to 500V. The low output capacitance and high dynamic impedance prevent the input voltage of the RH5RA50AA from exceeding its absolute maximum value of 13.5V when very fast high voltage transients are present. The ripple rejection ratio is also improved by several orders of magnitude.

LND1 improves the performance of the 5.0V linear regulator in the areas listed below. Observations and measurements were taken under three different loading conditions: no load, 10KΩ, and 5.0KΩ.

- a) DC operation extended from 13.5 to 500V
- b) High voltage transient protection
- c) Greatly improved ripple rejection ratio
- d) Eliminates power-up transients

DC Operation

The LND1 increases the maximum operating voltage range from 13.5 to 500VDC. In order for the output to maintain regulation, the voltage difference $(V_{IN} - V_{OUT})$, must be greater than the regulator’s specified dropout voltage of 30mV at 1.0mA load current. The measurements are shown below:

HV_{IN}	I_{IN}	V_{IN}	V_{OUT}	Conditions
10 to 500V	770nA	6.26V	5.02V	No load
10 to 500V	503μA	5.56V	5.02V	10KΩ
10 to 500V	1.0mA	5.30V	5.02V	5.0KΩ

Since the LND150N8 is connected in a source follower configuration, the value of V_{IN} can be estimated as shown in Figure 2.

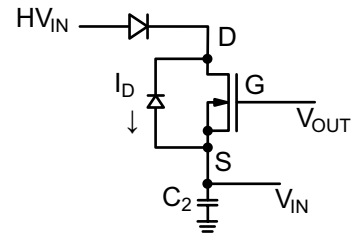

$$I_D = I_{DSS} \cdot (1 - V_{GS} / V_{GS(OFF)})^2$$

$$V_{GS} = V_{OUT} - V_{IN}$$

$$V_{IN} = V_{OUT} - V_{GS(OFF)} \cdot (1 - \sqrt{I_D / I_{DSS}})$$

Figure 2: V_{IN} Calculation

High Voltage Transient Protection

Positive and negative transient voltages were applied on HV_{IN} . The positive transient voltages are blocked by the LND1 and the negative transient voltages are blocked by the 1N4005 diode, which has a 600V PIV rating.

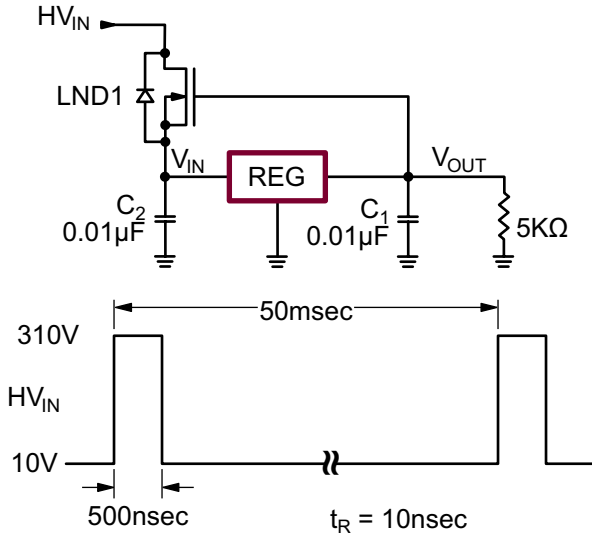
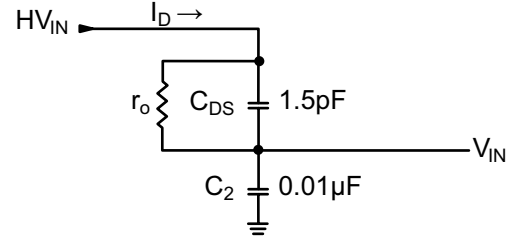

Figure 3: Positive Transient Test Condition

Figure 3 shows the test conditions used for simulating transient voltages. Positive 300V pulses with a pulse width of 500nsec, a rise time of 10nsec, and a duty cycle of 1.0% are superimposed on the 10VDC line of HV_{IN}. Figures 4a and 4b are waveforms showing HV_{IN}, V_{IN} and V_{OUT}.

The low drain-to-source capacitance, C_{DS} = C_{OSS} - C_{RSS} = 1.5pF, and high dynamic output impedance, r_O = 1.0MΩ, of the LND1 inherently give the LND1 excellent frequency response. The LND1 configured as a source follower will effectively protect high voltage transients on HV_{IN} from affecting V_{IN}. The only paths for transient voltages to get into V_{IN} are through the 1.5pF C_{DS} or 1.0MΩ r_O. Any transient voltages that pass through will be further attenuated by C₂. The increase in V_{IN} caused by the transient voltage can be estimated with the equivalent circuit shown in Figure 5.



r_O = AC resistance, typically 1.0MΩ
(almost no effect on V_{IN})

$$I_D = C_{DS} \frac{dv}{dt} = 1.5pF \cdot (300V/10ns) = 45mA$$

$$\Delta V_{IN} = \frac{I \cdot dt}{C_2} = \frac{(45mA) \cdot (10ns)}{0.01\mu F}$$

$$\Delta V_{IN} = 45mV_{PEAK}$$

Figure 5: Estimate V_{IN} Increase Due to Transients

Negative 300V pulses with a pulse width of 500nsec, a rise time of 10nsec, and a duty cycle of 1.0% are superimposed on the 10VDC line of HV_{IN}. The 1N4005 diode is reverse biased and blocks the negative voltage. Figures 6a and 6b are waveforms showing HV_{IN}, V_{IN}, and V_{OUT}.

The LND1 with the 1N4005 effectively protects the input of the 5.0V regulator from positive and negative transient voltages. Theoretical and measured values indicated V_{IN} will never exceed its maximum rating of 13.5V.

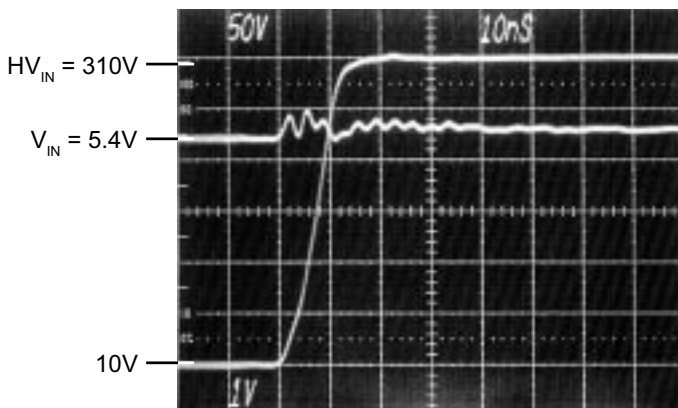

Figure 4a: HV_{IN} and V_{IN}

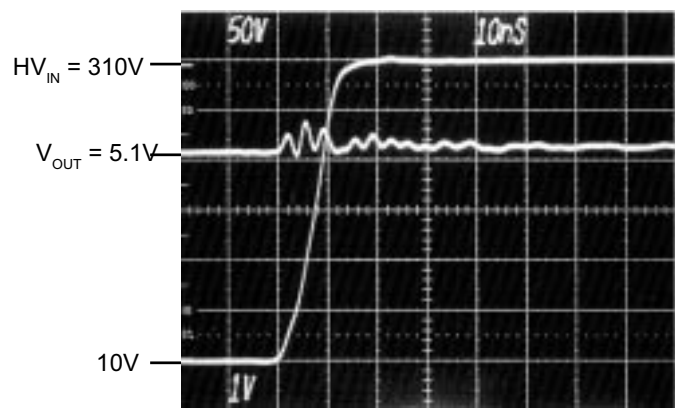

Figure 4b: HV_{IN} and V_{OUT}

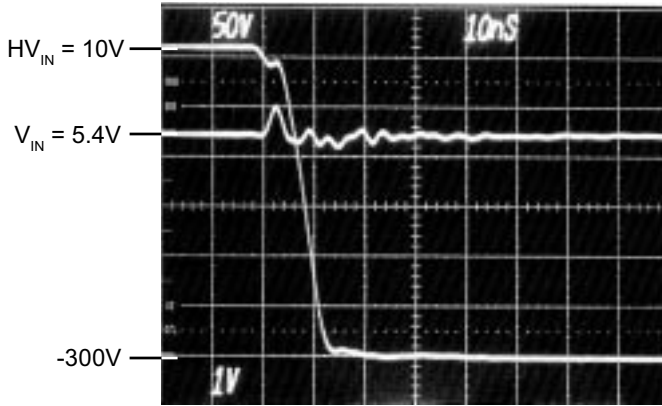

Figure 6a: HV_{IN} and V_{IN}

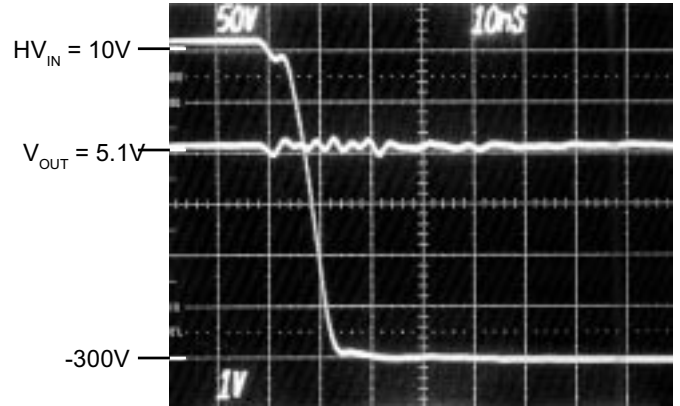

Figure 6b: HV_{IN} and V_{OUT}

Ripple Rejection Ratio

The ripple rejection ratio, RR, demonstrates the LND150N8's capability of filtering AC ripple on the input of HV_{IN}. A 4.0V_{P-P}, 1.0MHz sinusoidal signal was applied to the 5.0V regulator with and without the LND1. Figure 7 shows the test conditions.

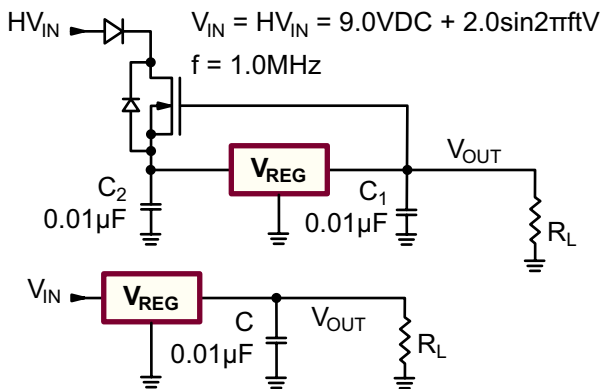

Figure 7: Ripple Rejection Test Conditions

Measured results are as follows:

Peak-to-peak output AC voltage,

$$RR = 20\log\left(\frac{V_{OUT}}{4.0V}\right)$$

V _{OUT} with LND1	V _{OUT} without LND1	Conditions
1.3mV, RR = -70dB	2.90V, RR = -2.8dB	No load
1.3mV, RR = -70dB	2.90V, RR = -2.8dB	10KΩ
1.3mV, RR = -70dB	2.90V, RR = -2.8dB	5.0KΩ

The amount of AC attenuation due to the LND1 can be estimated by the equivalent circuit and equations shown in Figure 8.

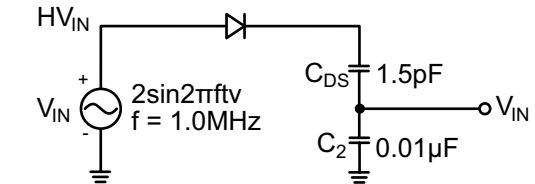

$$V_{IN} = \frac{C_{DS}}{C_{DS} + C_2} \cdot HV_{IN}$$

$$V_{IN} = \frac{1.5pF}{1.5pF + 0.01\mu F} \cdot (4.0_{P-P})$$

$$V_{IN} = 600\mu V_{P-P}$$

Figure 8: Ripple Rejection Calculation

The ripple rejection ratio was improved by a factor of 1000. Such a high ripple rejection ratio is particularly useful for off-line applications. A typical 240VAC off-line application is shown in Figure 9a.

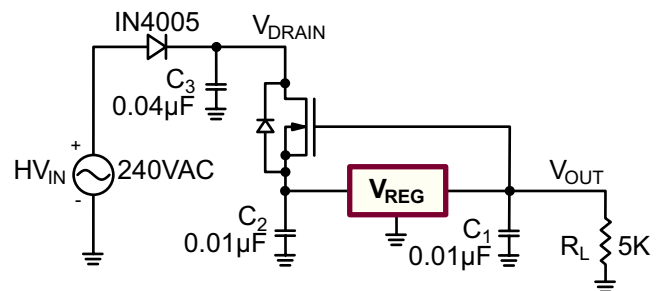

Figure 9a: 240VAC Off-Line 5.0V Regulator

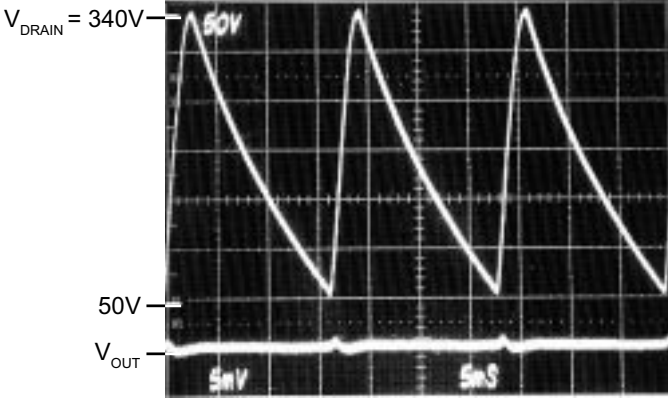

Figure 9b: V_{DRAIN} and V_{OUT}

Figure 9b shows the voltage waveforms at the drain, V_{DRAIN} , of the LND1 and the AC voltage at V_{OUT} . There were 290V of AC ripple observed on V_{DRAIN} with less than 2.0mV of ripples on V_{OUT} .

C_3 is a high voltage holding capacitor. In order to minimize size and cost, more often than not it is desirable to select C_3 to be as small as possible. The high ripple rejection ratio helps in achieving a small size of C_3 because it allows for large AC input voltage with negligible AC output voltage.

Power-Up Transient Suppression

The circuits shown in Figures 10a and 10b are powered up from 0 to 10V in 100nsec. This test demonstrates the stability of the circuit, the amount of overshoot voltage on V_{OUT} , and the amount of time required for the output to settle. Large overshoot voltages on V_{OUT} may damage sensitive loads, such as CMOS circuits.

The test results were:

With LND1		Without LND1		Conditions
V_{PEAK}	t_r	V_{PEAK}	t_r	
0.0V	50µsec	7.6V	1.0µsec	No load
0.0V	60µsec	7.0V	1.0µsec	10KΩ
0.0V	80µsec	6.9V	1.0µsec	5.0KΩ

While there was a large overshoot voltage without the LND1, no overshoots were observed in the circuit employing the LND1. Loads prone to damage by overshoots can be effectively protected by using the LND1.

Conclusion

The high voltage protected, low power, 5.0V linear regulator in Figure 1 is a robust, compact, cost effective regulator. It can operate up to 500VDC, protect against ±500V transients, and has a maximum quiescent current of 1.0µA. The electrical characteristics of the LND1 allow for the 500V operation and protection. Some examples are proximity controlled light switches, street lamp control, fax machines, modems, and power supplies for CMOS ICs in automotive, avionics and a variety of applications.

Other Application Ideas

The circuit in Figure 1 can be easily modified for higher current capability. The LND1 can be replaced by the Supertex DN2540N5, which is a 400V, 150mA depletion mode MOSFET in a TO-220 package. In case the current is low, and the worst case power dissipation for the DN25 is below 1Watt, the TO-92 version (part #DN2540N3) can be used to save space and cost. Figure 11 utilizes an op-amp and an enhancement-mode MOSFET for a much higher output current capability. Figure 12 is an off-line street lamp control where V_{SENSE} is the input voltage from a light sensing device.

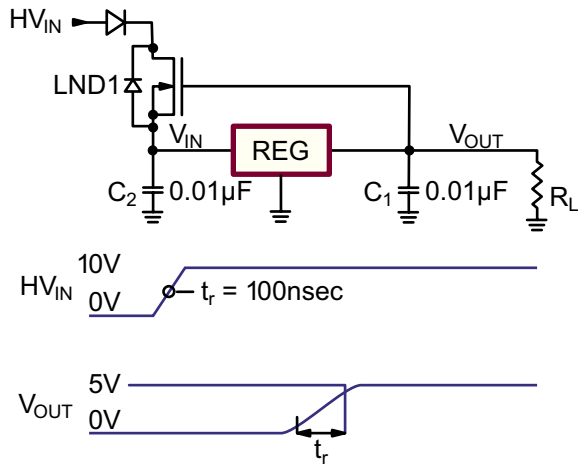

Figure 10a: Power Up Response with LND1

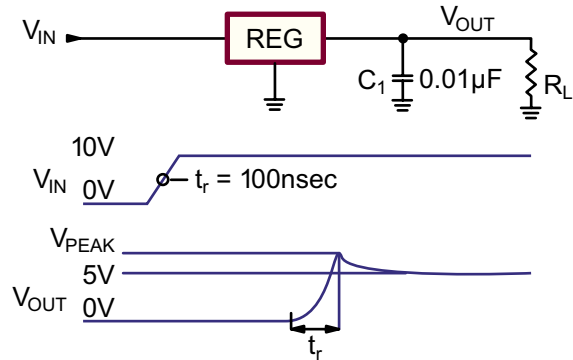

Figure 10b: Power Up Response without LND1

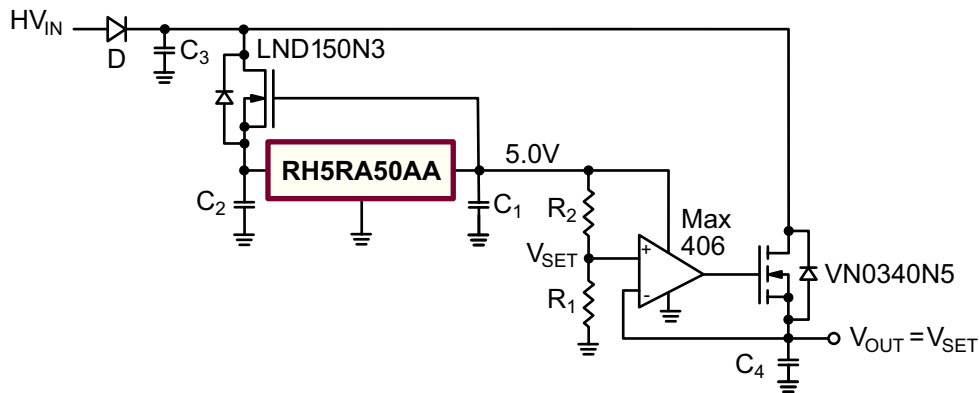

Figure 11: High Output Current Linear Regulator

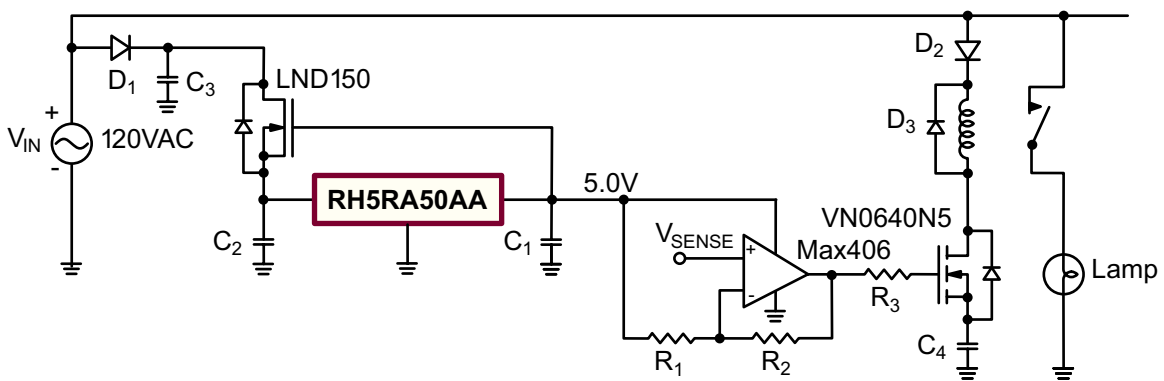

Figure 12: Off-Line Street Lamp Controller

Supertex inc. does not recommend the use of its products in life support applications, and will not knowingly sell them for use in such applications unless it receives an adequate "product liability indemnification insurance agreement." Supertex inc. does not assume responsibility for use of devices described, and limits its liability to the replacement of the devices determined defective due to workmanship. No responsibility is assumed for possible omissions and inaccuracies. Circuitry and specifications are subject to change without notice. For the latest product specifications refer to the Supertex inc. website: <http://www.supertex.com>.