

Title		
SMDK6400 (S3C6400) Evaluation Board		
Size	Document Number	Rev
A3	B-to-B Connector	0.0
Date:	Thursday, December 14, 2006	Sheet 1 of 15

### AMD Flash Memory (SOCKET)

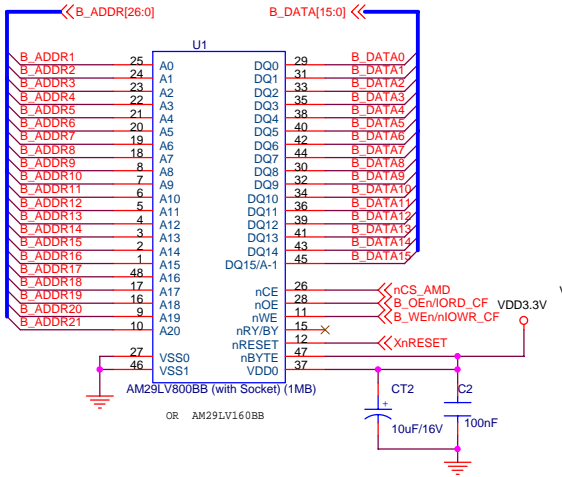

### SRAM

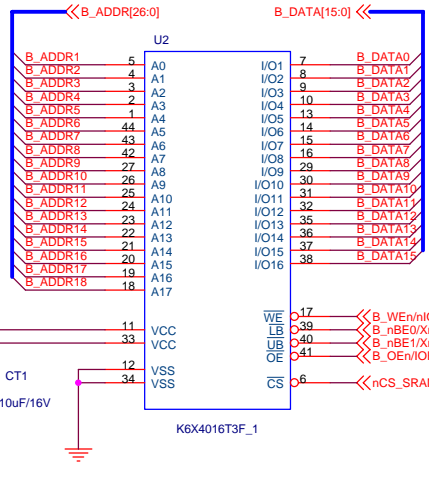

### <Silk>

CFGB1:nCS0	SRAM Selector
[3]	External
[2]	SRAM
[1]	NOR (AMD)

CFGB2:nCS1	SRAM Selector
[4]	External
[3]	CS8900
[2]	SRAM
[1]	NOR (AMD)

  

CFGB3:nCS2	SRAM Selector
CFGB4:nCS3	SRAM Selector
[4]	External
[3]	CS8900
[2]	XD card
[1]	NAND

  

CFGB5:nCS4	SRAM Selector
CFGB6:nCS5	SRAM Selector
[4]	CS8900
[3]	SRAM
[2]	NOR (AMD)
[1]	CF card

### NAND Flash memory (SOCKET)

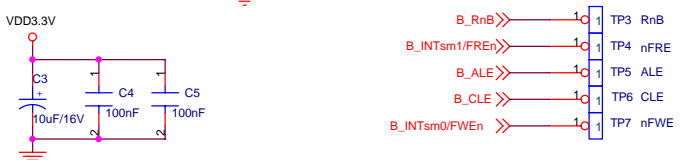
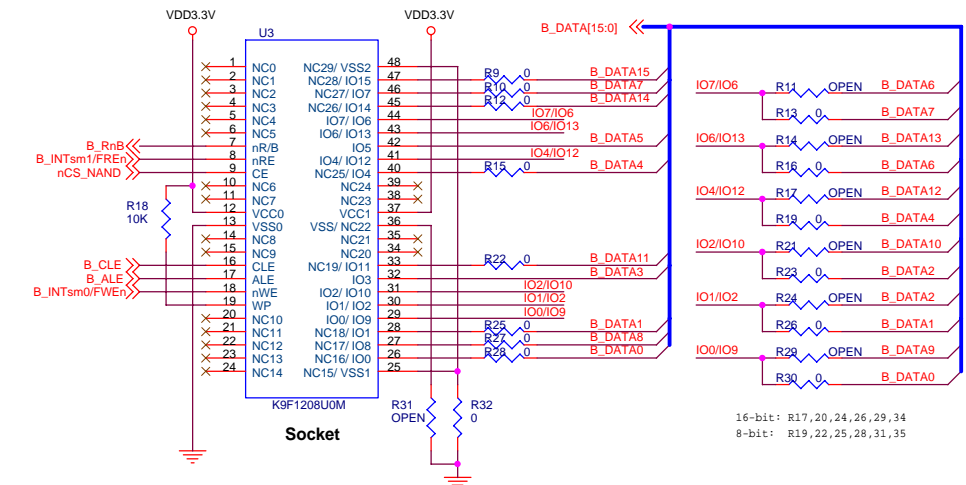

### XD PICTURE CARD

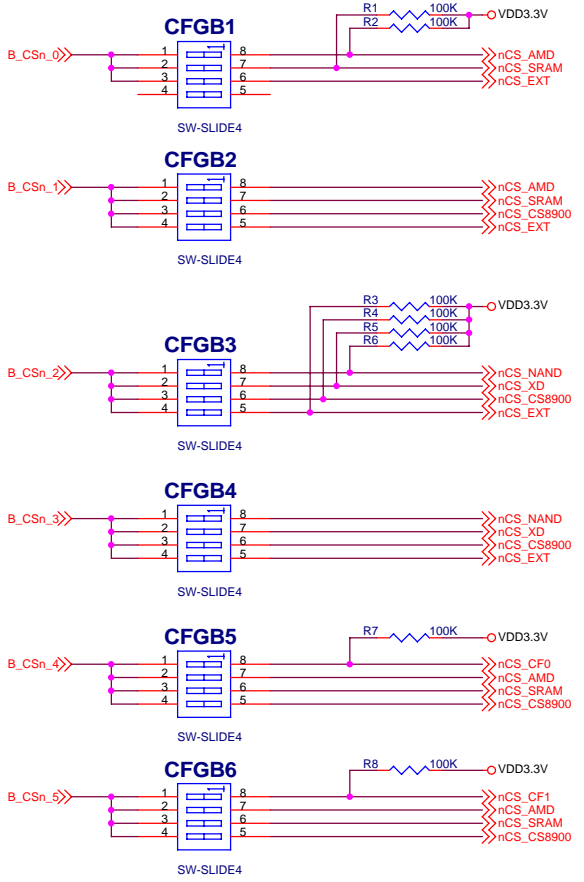
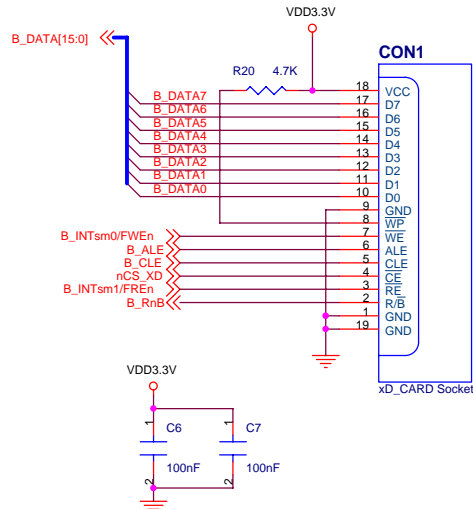

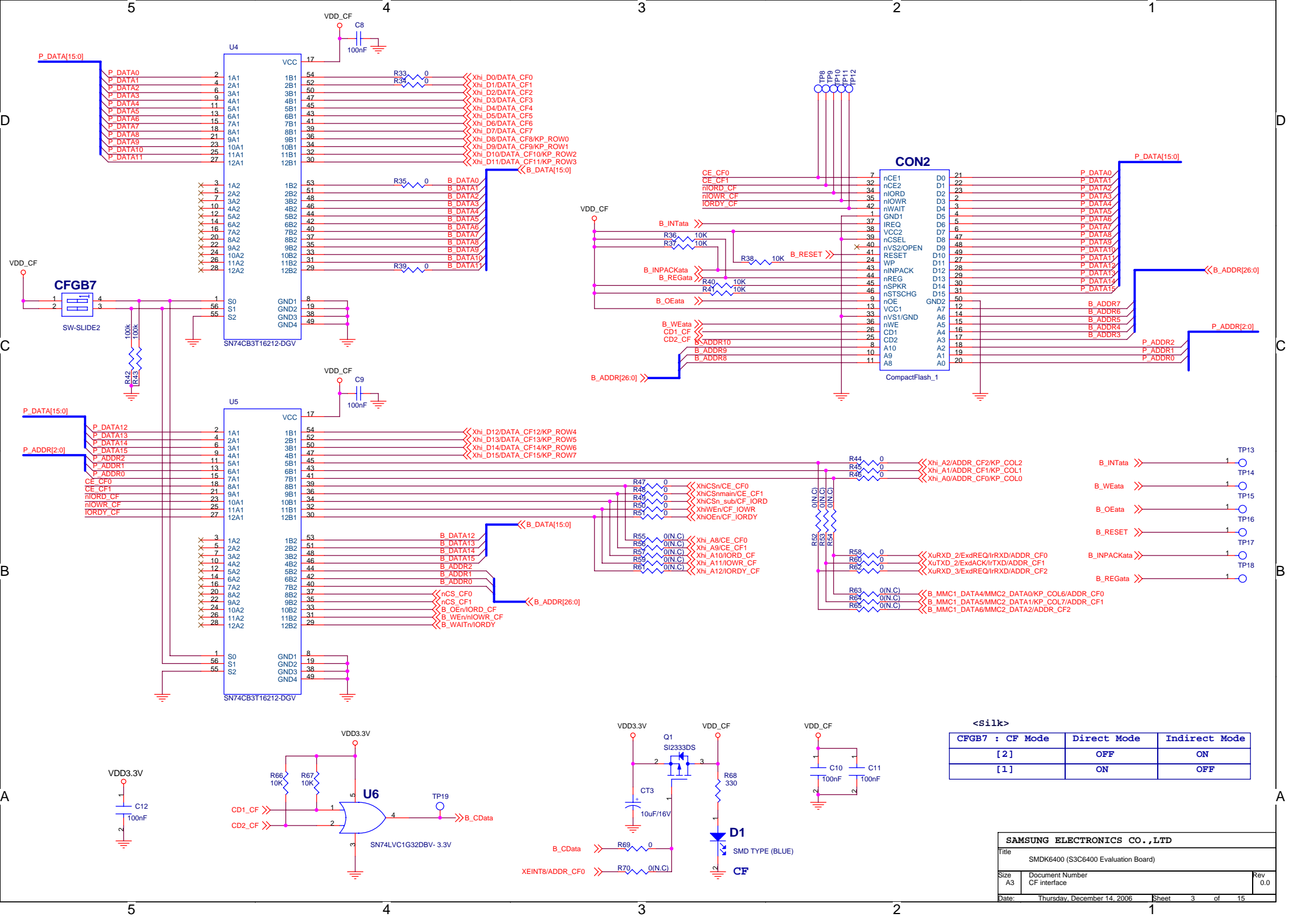

<Silk>

CFGB7 : CF Mode	Direct Mode	Indirect Mode
[ 2 ]	OFF	ON
[ 1 ]	ON	OFF

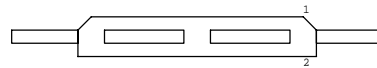
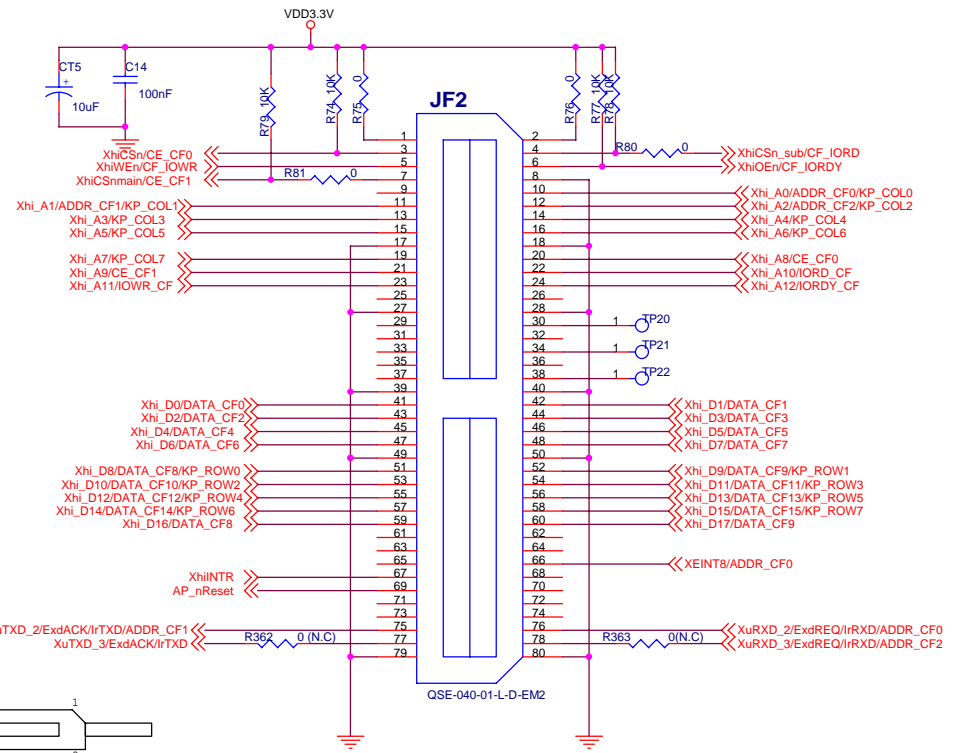
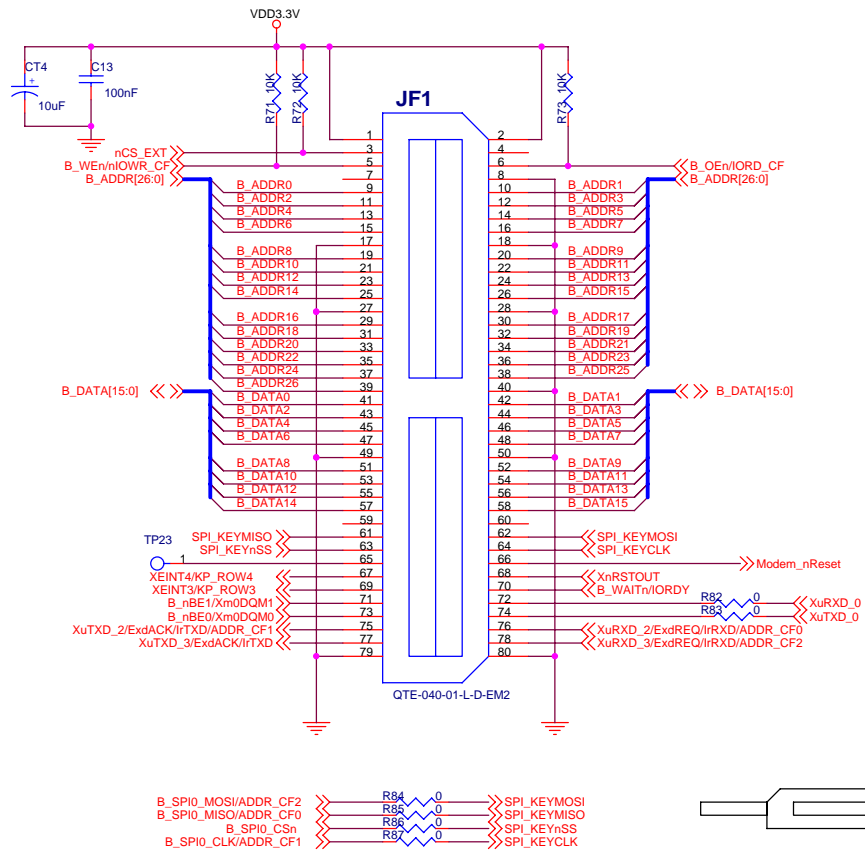

-興暖-  
External Keyboard B/D請暖 聯唸。  
JF01/JF02陸 撫照 聯唸 陸棟 檢

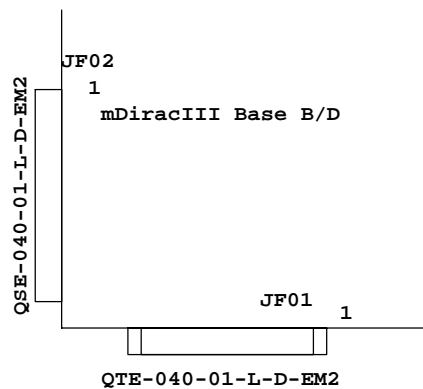

SAMSUNG ELECTRONICS CO., LTD		
Title	SMDK6400 (S3C6400 Evaluation Board)	
Size	Document Number	Rev
A3	External Bus connector	0.0
Date:	Thursday, December 14, 2006	Sheet 4 of 15

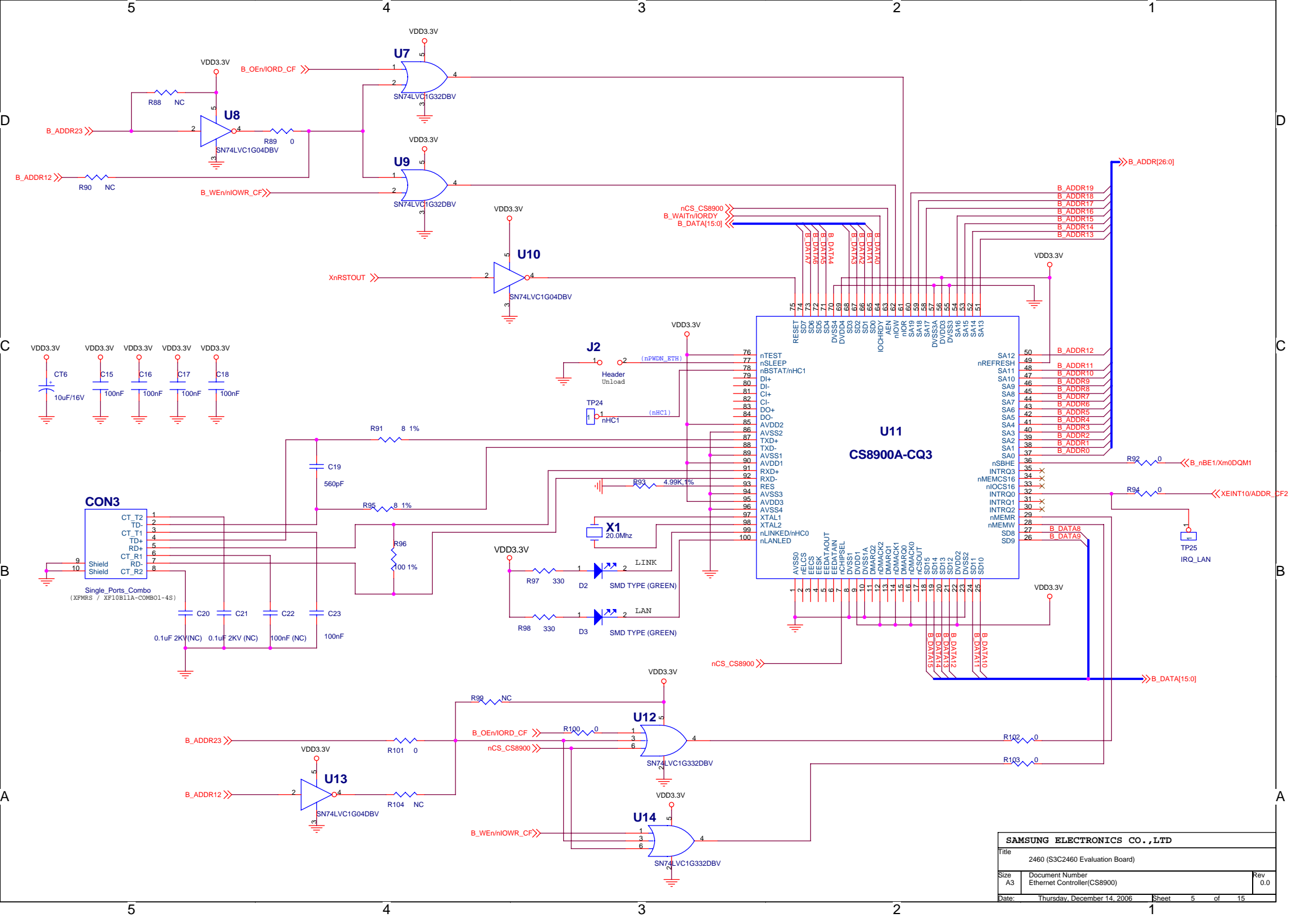

<b>SAMSUNG ELECTRONICS CO., LTD</b>		
Title	2460 (S3C2460 Evaluation Board)	
Size	Document Number	Rev
A3	Ethernet Controller(CS8900)	0.0
Date:	Thursday, December 14, 2006	Sheet 5 of 15

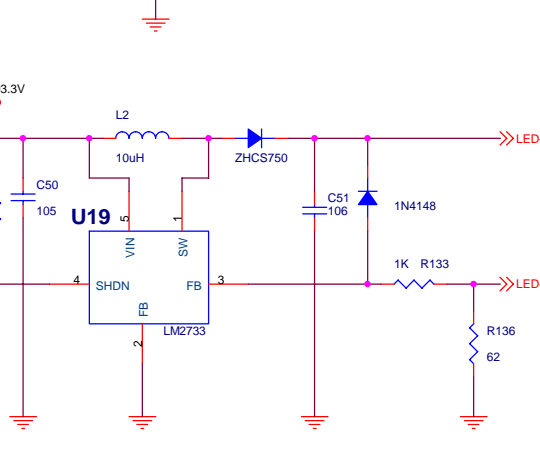
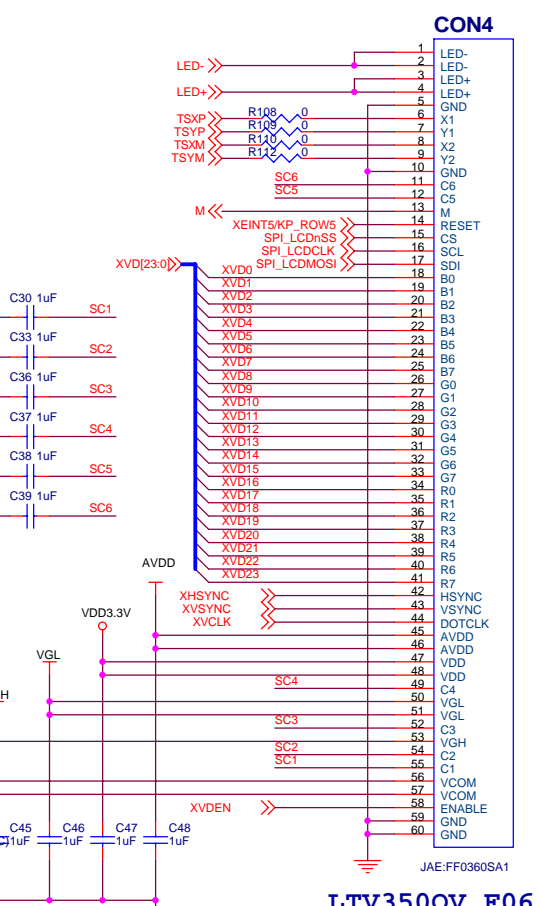
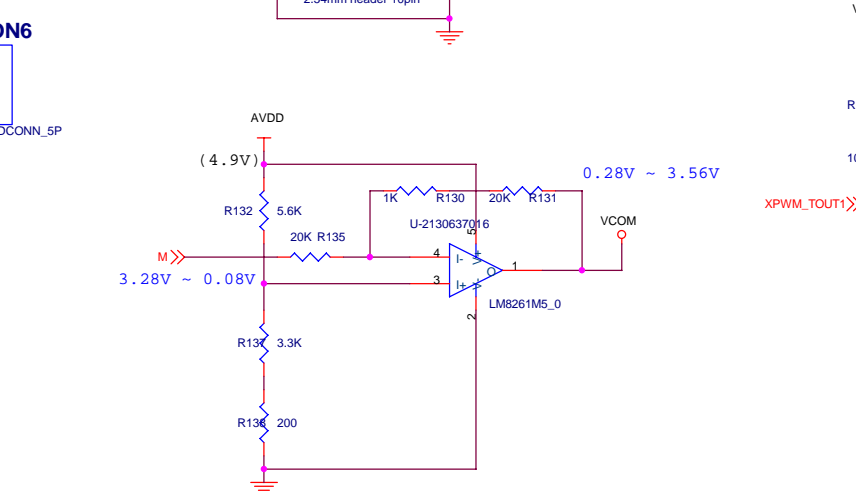
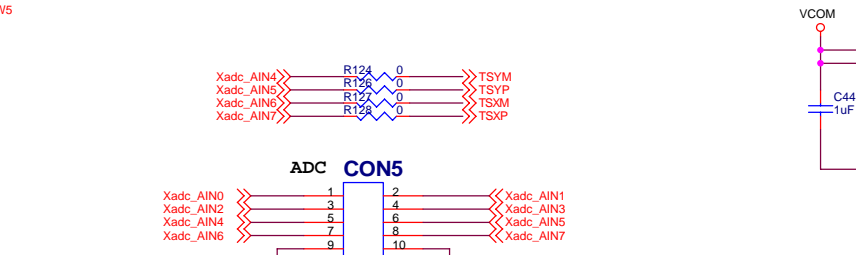
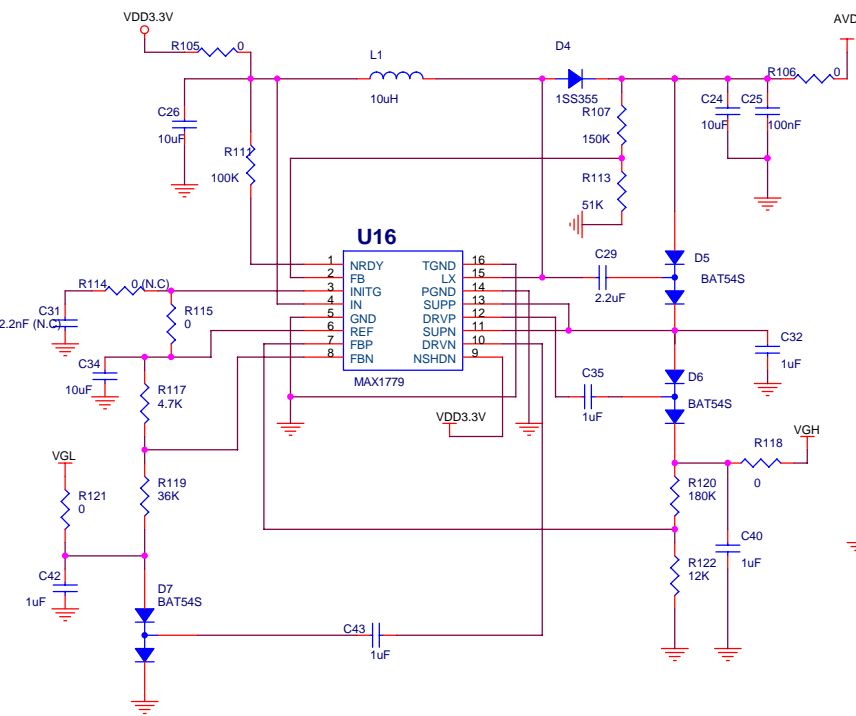
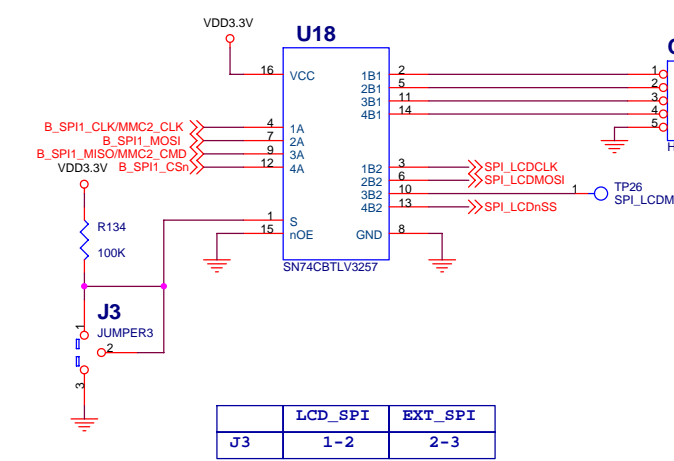
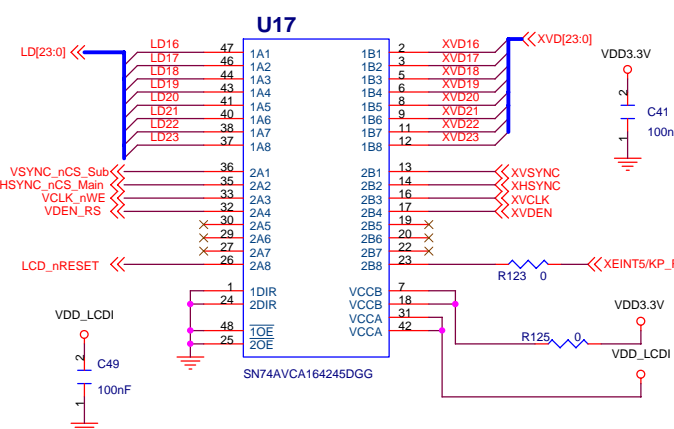
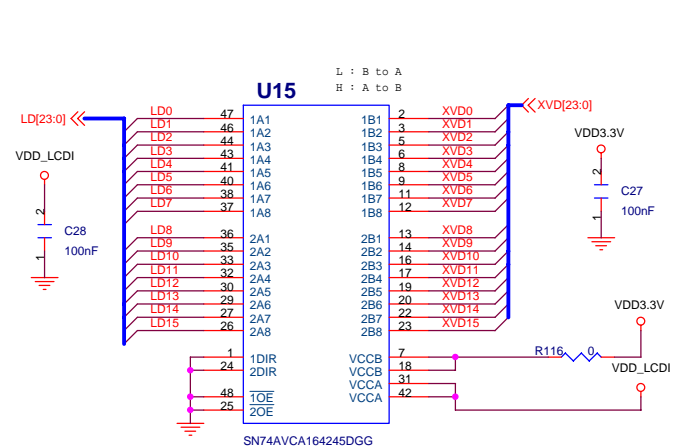

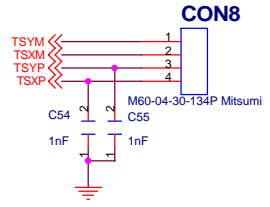
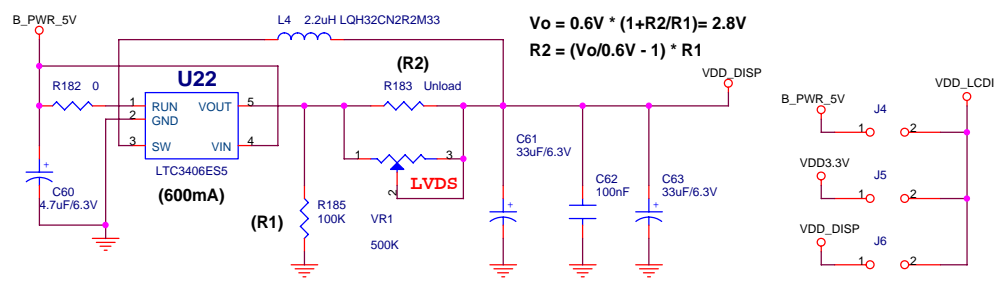
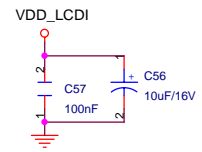
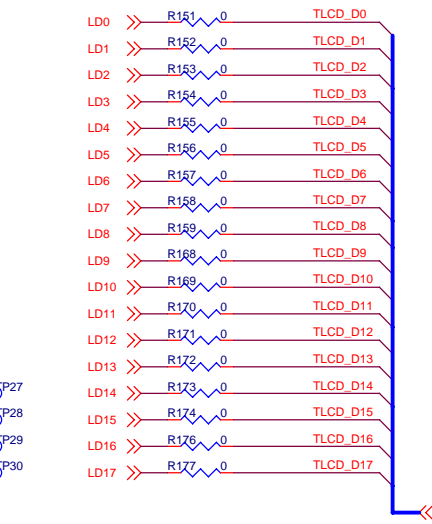
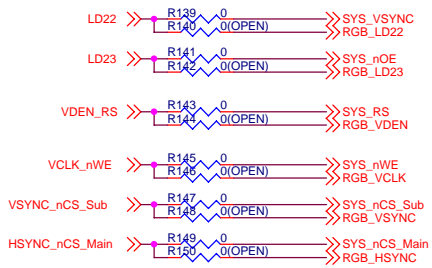

**Main LCD Touch Screen**

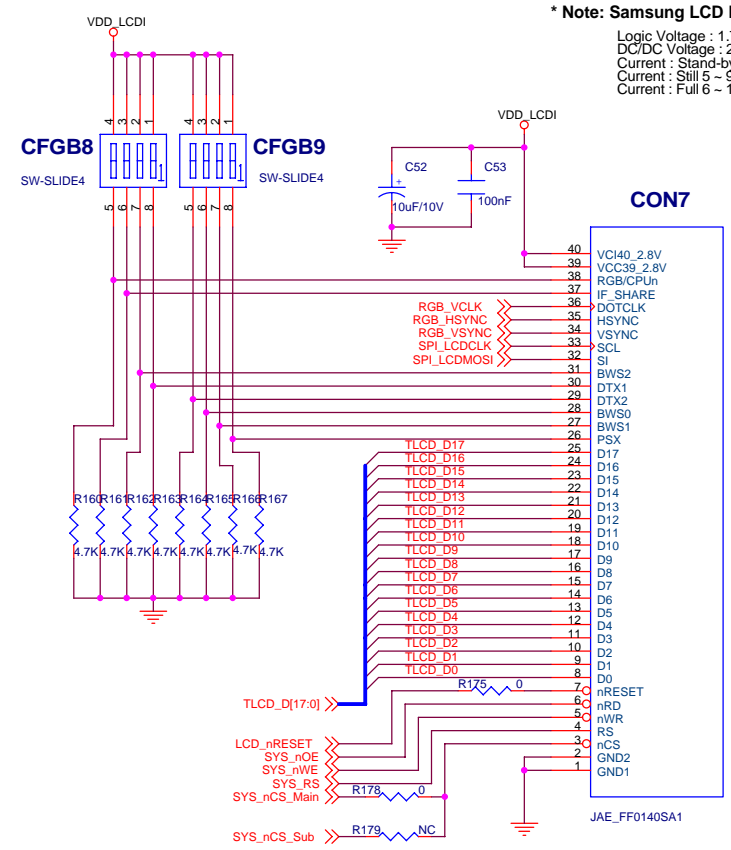

**\* Note: Samsung LCD LTS222QV-F01 (2.22")**  
 Logic Voltage : 1.7/2.8/3.3V  
 DC/DC Voltage : 2.5/2.8/3.3V  
 Current : Stand-by 30 ~ 100uA  
 Current : Still 5 ~ 9mA  
 Current : Full 6 ~ 10mA

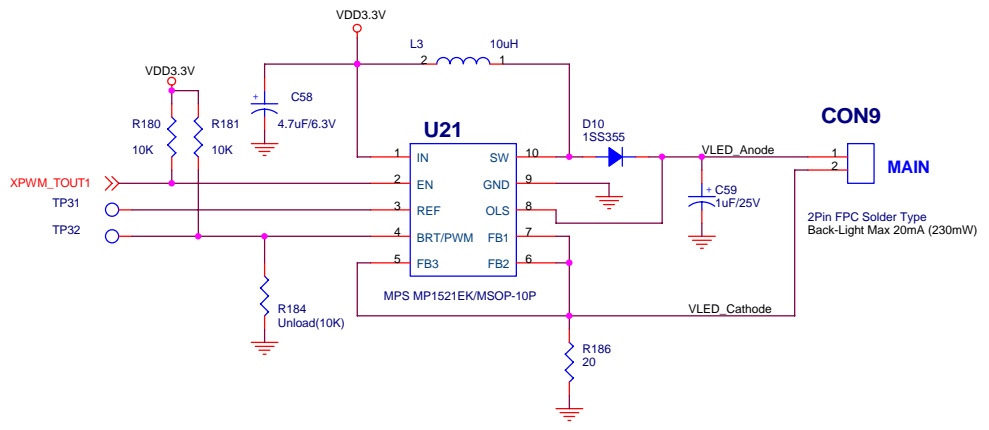

SAMSUNG ELECTRONICS CO.,LTD		
Title		
SMDK6400 (S3C6400) Evaluation Board		
Size	Document Number	Rev
A3	LCD-CPU16bit/RGB_Serial6bit	0.3
Date:	Thursday, December 14, 2006	Sheet 7 of 15

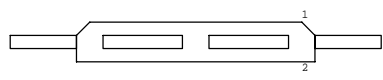
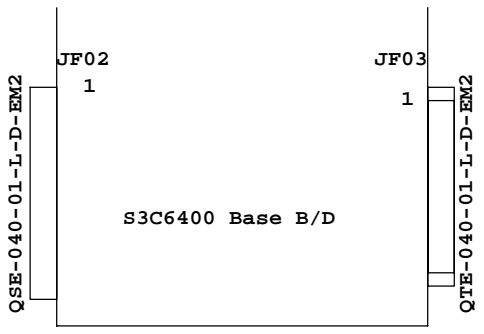
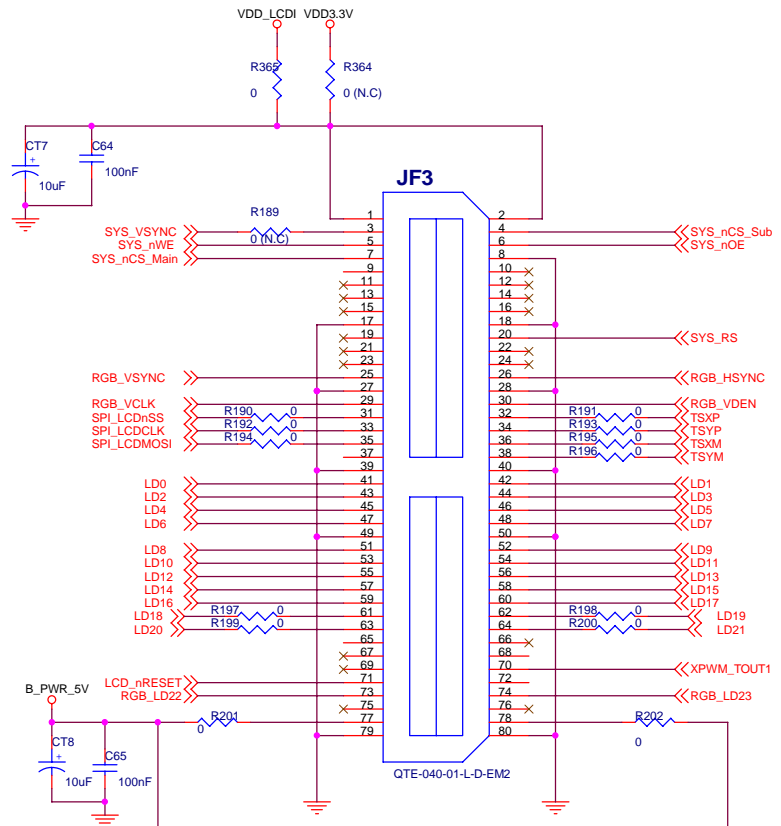

-興暖-  
 JF02/JF03槽 無煎 翳念  
 陸棟 檢 .

<b>SAMSUNG ELECTRONICS CO.,LTD</b>		
Title SMDK6400-BASE (S3C6400 Evaluation Board)		
Size A3	Document Number LCD/LCD Ext	Rev 0.0
Date: Thursday, December 14, 2006	Sheet 8	of 15



## Camera Interface

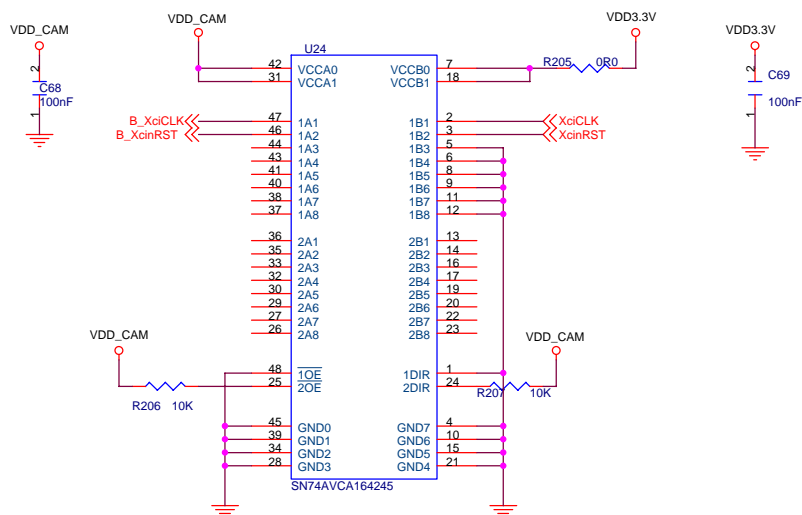
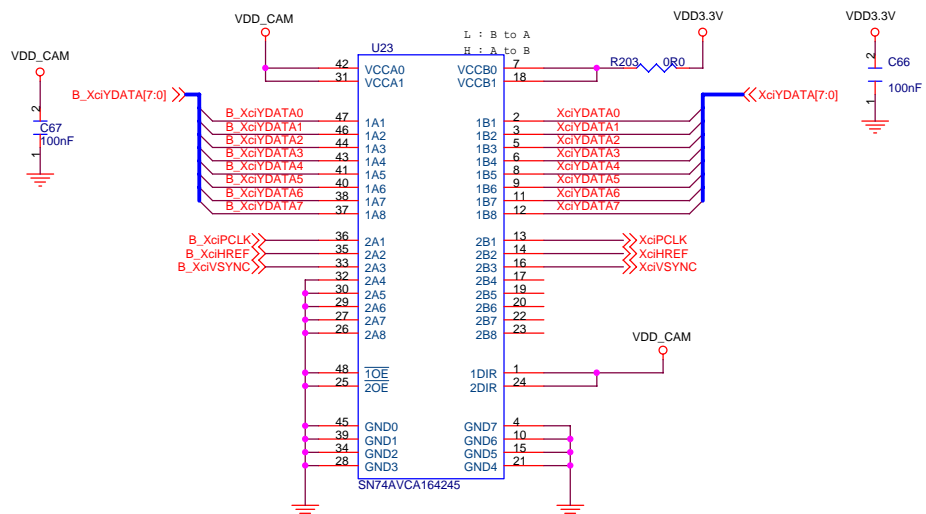
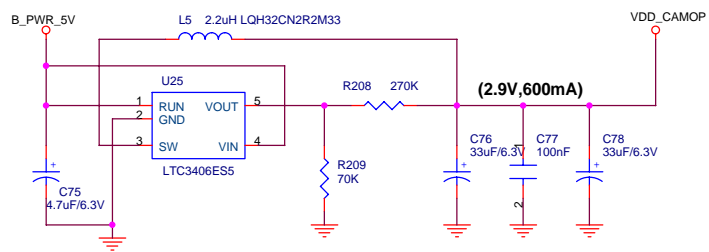
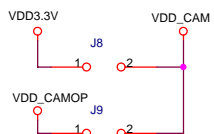
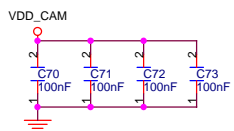
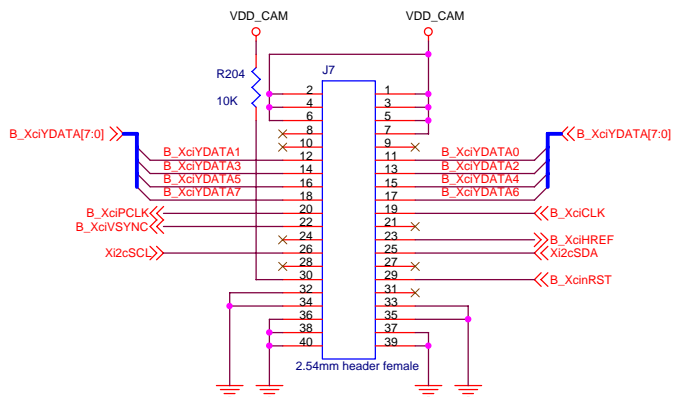

## IIC Interface

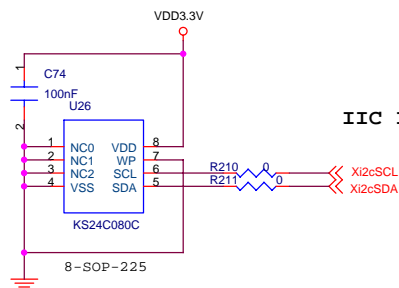

Title		
SMDK6400 (S3C6400 Evaluation Board)		
Size	Document Number	Rev
A3	Camera/IIC	0.0
Date:	Thursday, December 14, 2006	Sheet 9 of 15

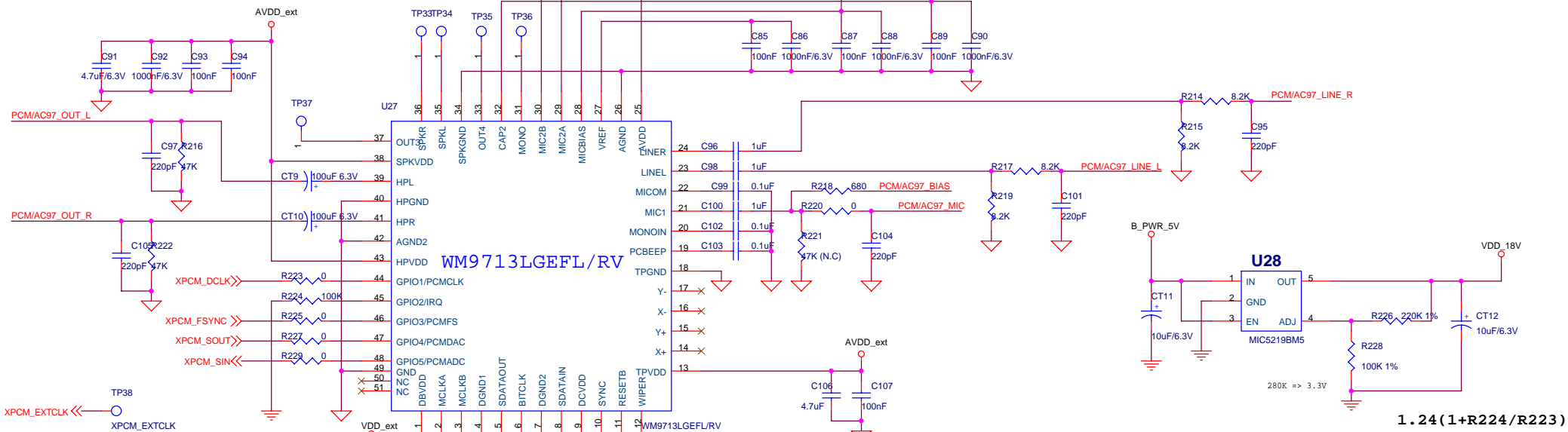

$1.24(1+R224/R223)$

<Silk>

CFG1: Audio Connector	Selector
[1] : Speaker	
[2] : Mic	Off:IIS
[3] : LineIn	On:PCM_AC97
[4] : Reserved	

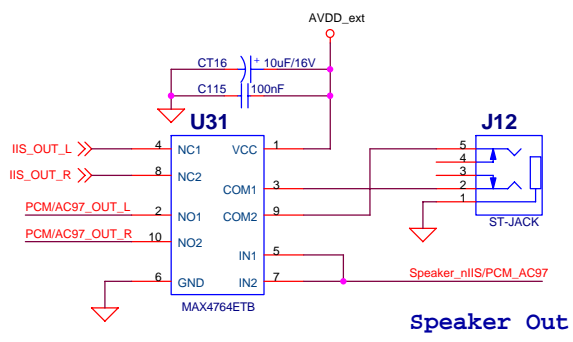
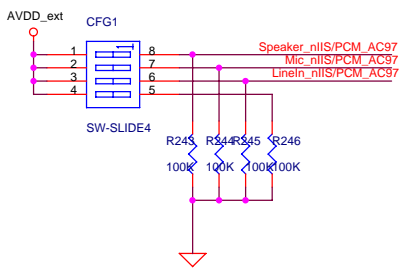

Speaker Out

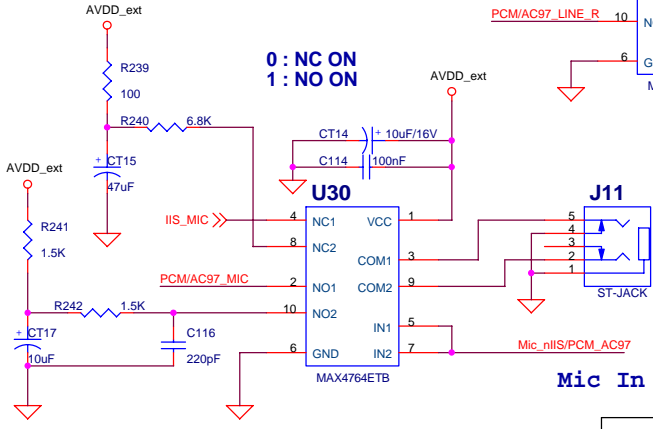

Mic In

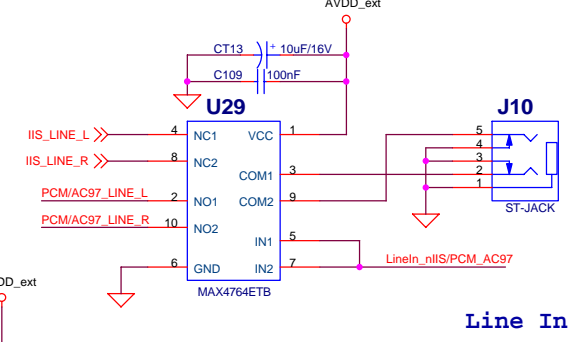

Line In

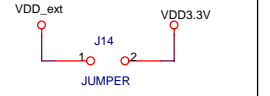
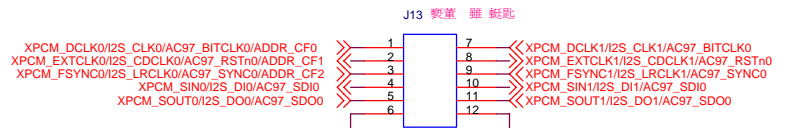
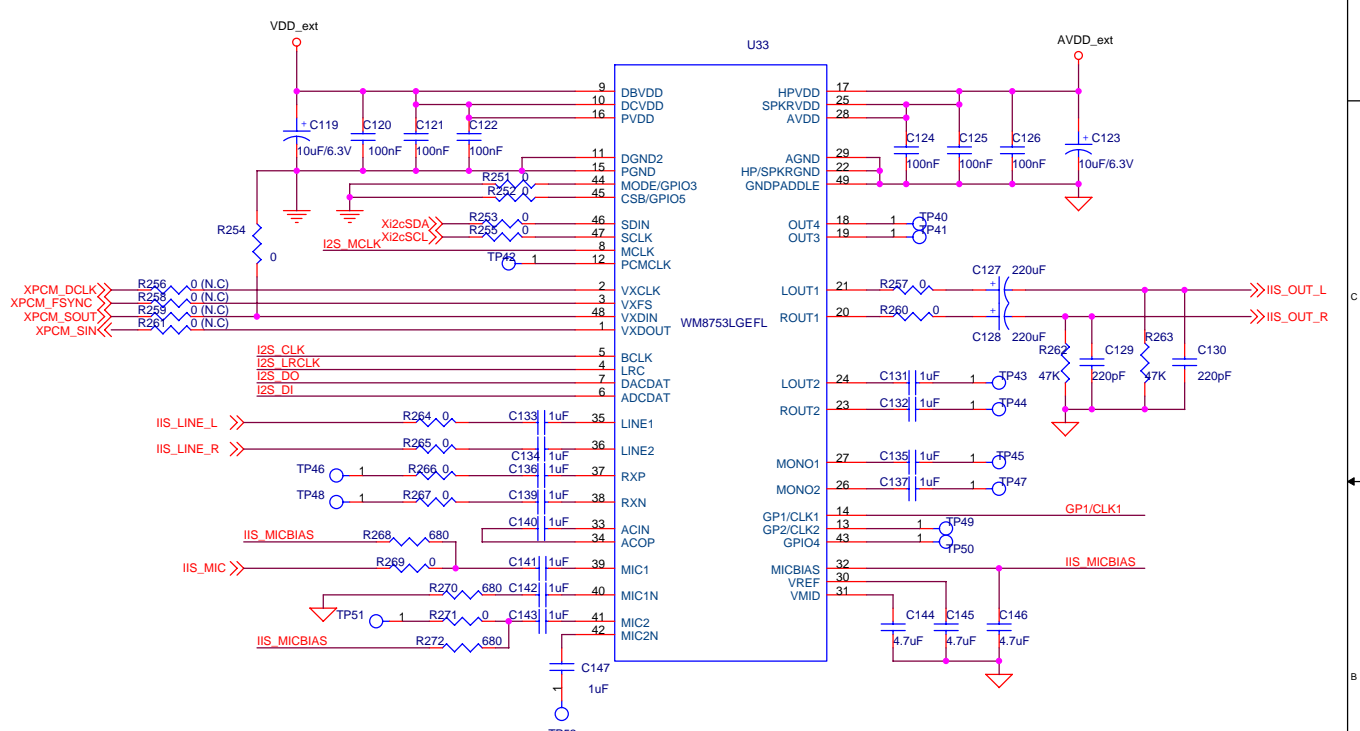
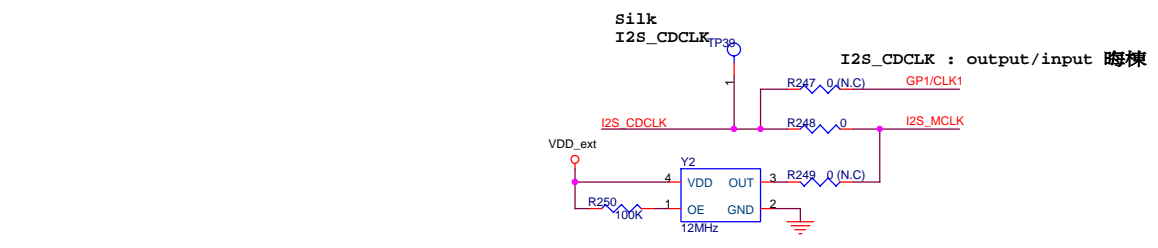
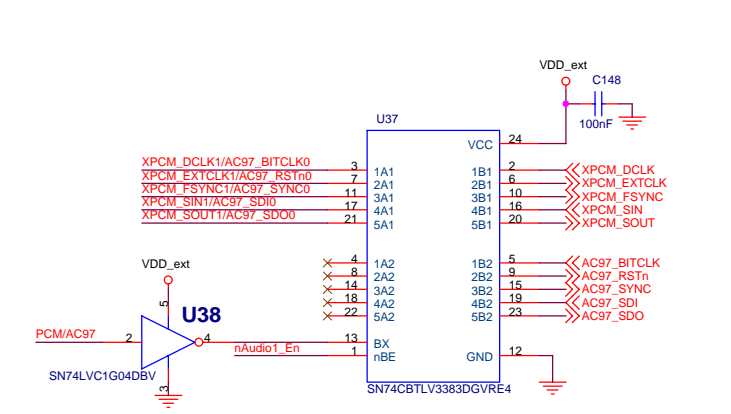
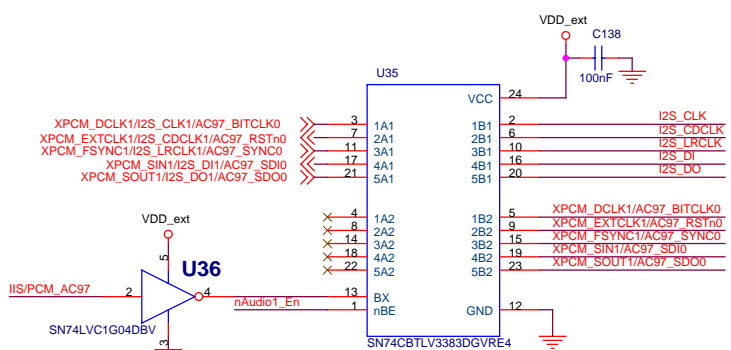
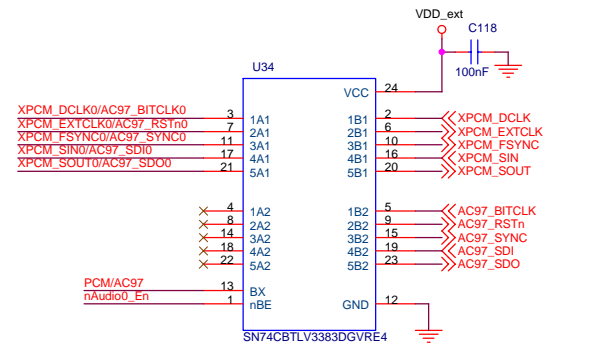
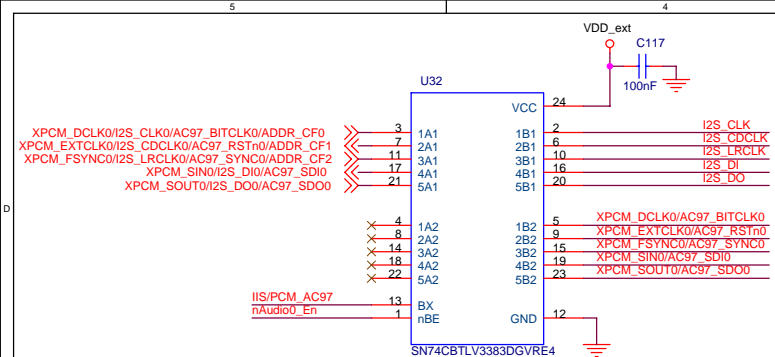

<silks>

CFG2: Audio Port	Selector
[1]	OFF: Audio0-IIS Audio1-PCMorAC97 ON: Audio0-PCMorAC97 Audio1-IIS
[2]	OFF: Audio0-PCM Audio1-AC97 ON: Audio0-AC97 Audio1-PCM
[3] : Audio0	OFF: Enable ON: Disable
[4] : Audio1	OFF: Enable ON: Disable

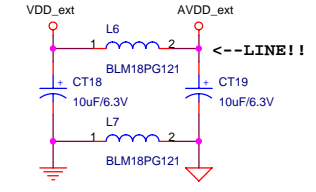
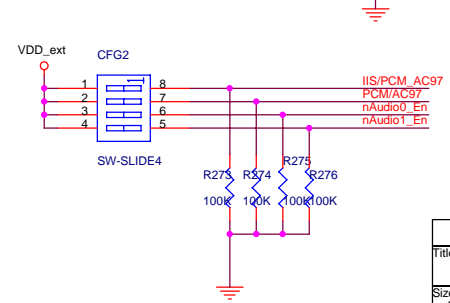

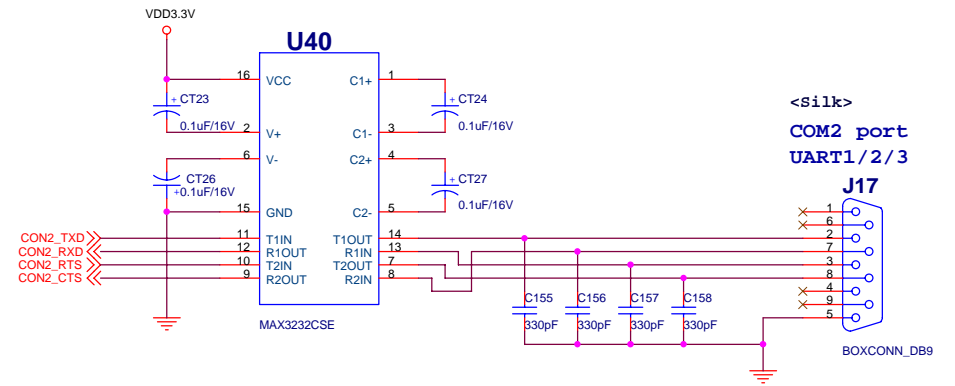
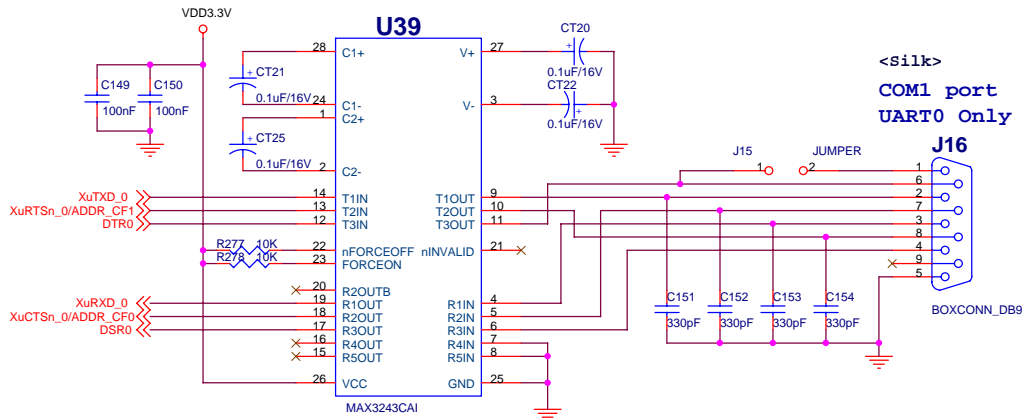

XEINT6/KP\_ROW6 >> R279 0 (N.C.) >> DTR0  
XEINT7/KP\_ROW7 >> R280 0 (N.C.) >> DSR0

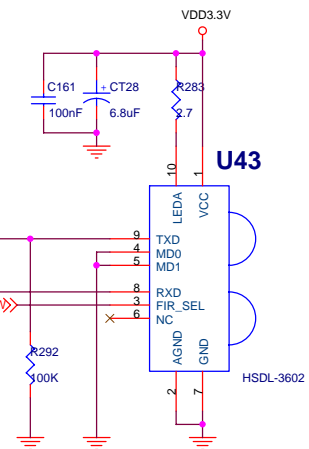
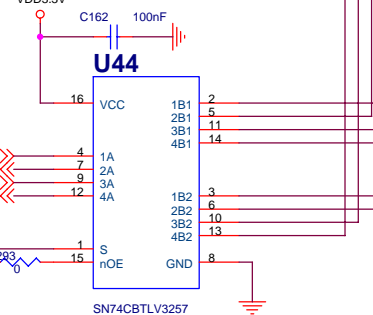
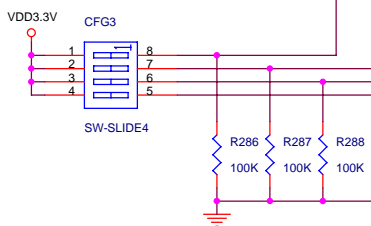
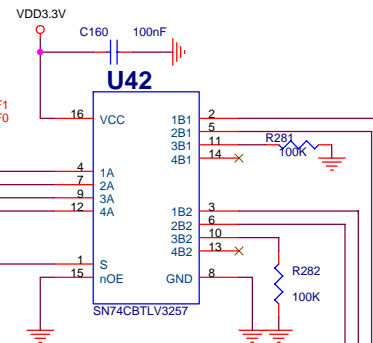
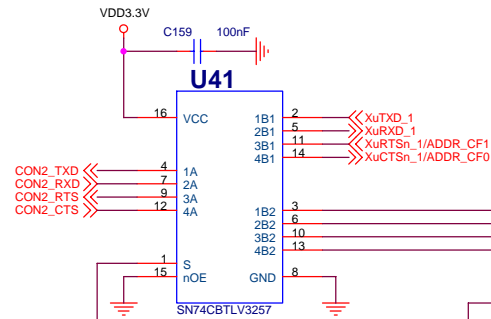

S - L : B1 port,  
H : B2 port  
OE - L : Output enable  
H : all disconnect

**COM2 port  
CFG3 Control**

<silkscreen>

CFG3 : COM2 port	PIN1	PIN2	PIN3	PIN4
UART1	OFF	X	X	X
UART2	ON	OFF	OFF	OFF
UART3	ON	ON	ON	OFF
IrDA (U2)	X	X	ON	OFF
IrDA (U3)	X	X	OFF	OFF

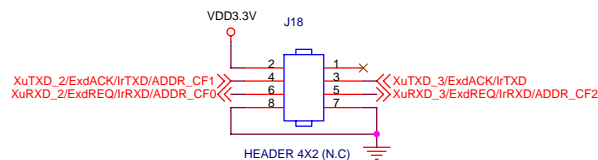

**SIR mode only**

Title SMDK6400 (S3C6400 Evaluation Board)		
Size A3	Document Number UART/IrDA	Rev 0.0
Date: Thursday, December 14, 2006	Sheet 12	of 15

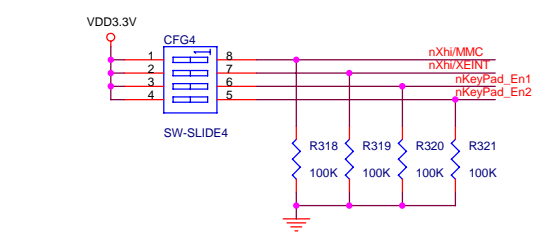
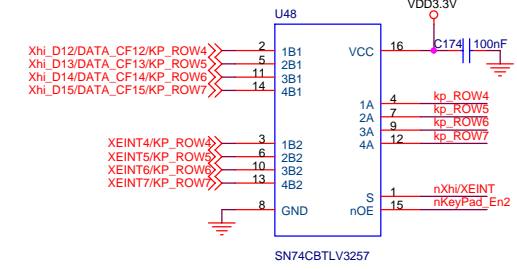
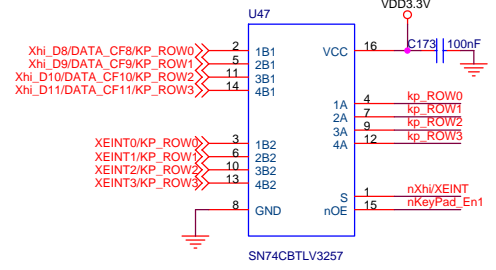
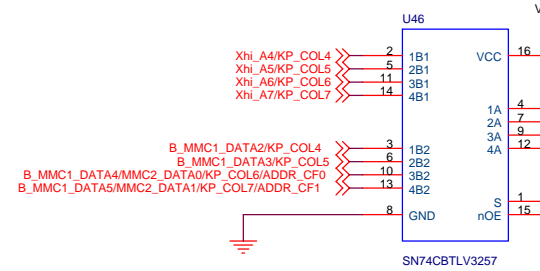
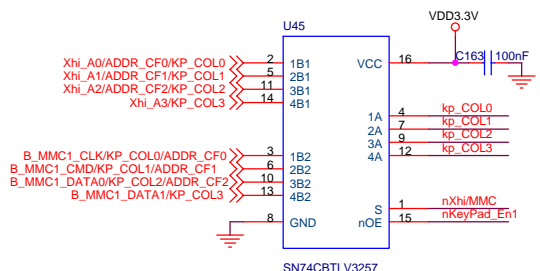

**KeyPad CFG4 Control** <Silk>

CFG4 :	Func
<b>1 (Column)</b>	OFF : Host I/F ON : MMC
<b>2 (Row)</b>	OFF : Host I/F ON : XEINT
<b>3 (Key_En1)</b>	OFF : Key Enable(Low 4x4) ON : Key Disable(Low 4x4)
<b>4 (Key_En2)</b>	OFF : Key Enable(High 4x4) ON : Key Disable(High 4x4)

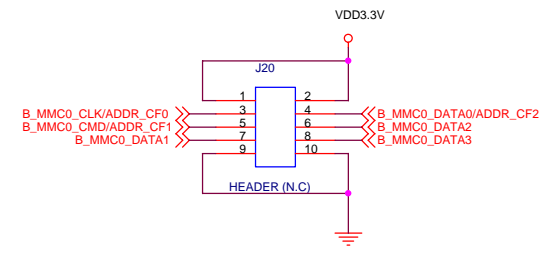
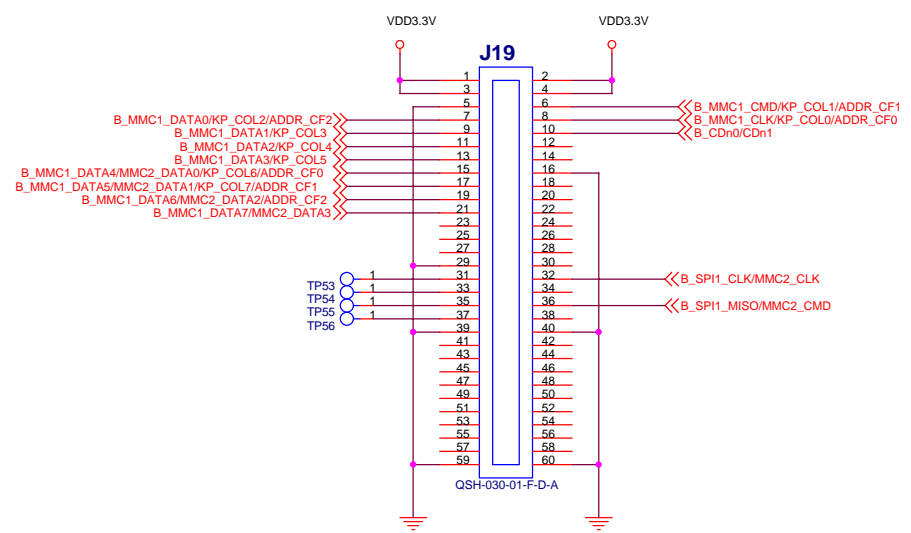
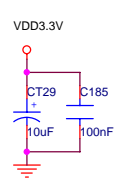
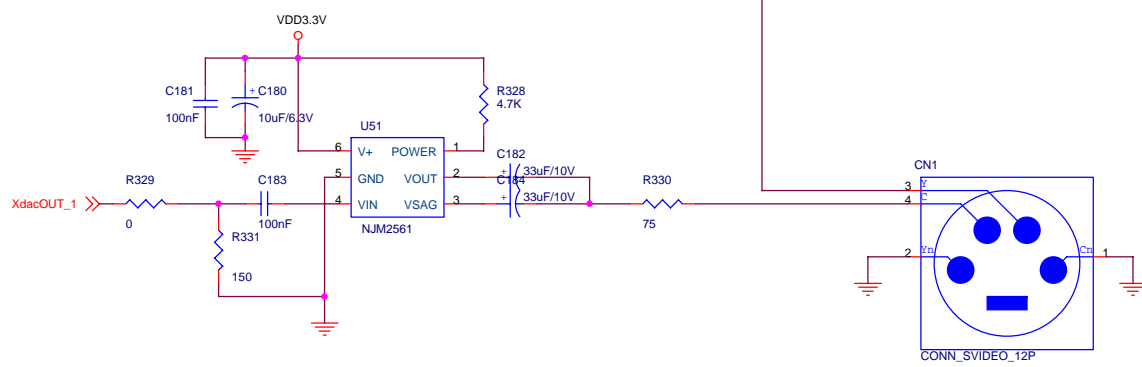
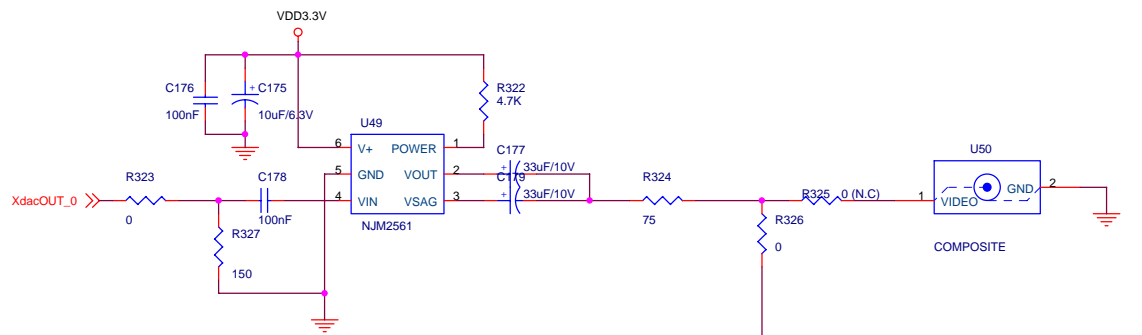

Title		
SMDK6400 (S3C6400 Evaluation Board)		
Size	Document Number	Rev
A3	HSMC/TV	0.0
Date:	Thursday, December 14, 2006	Sheet 14 of 15

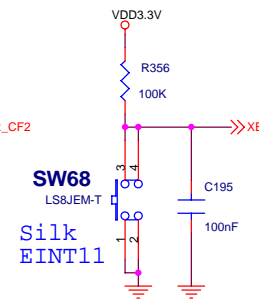
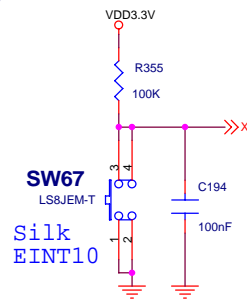
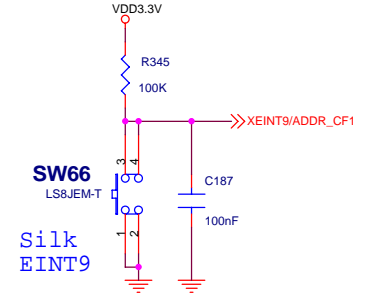
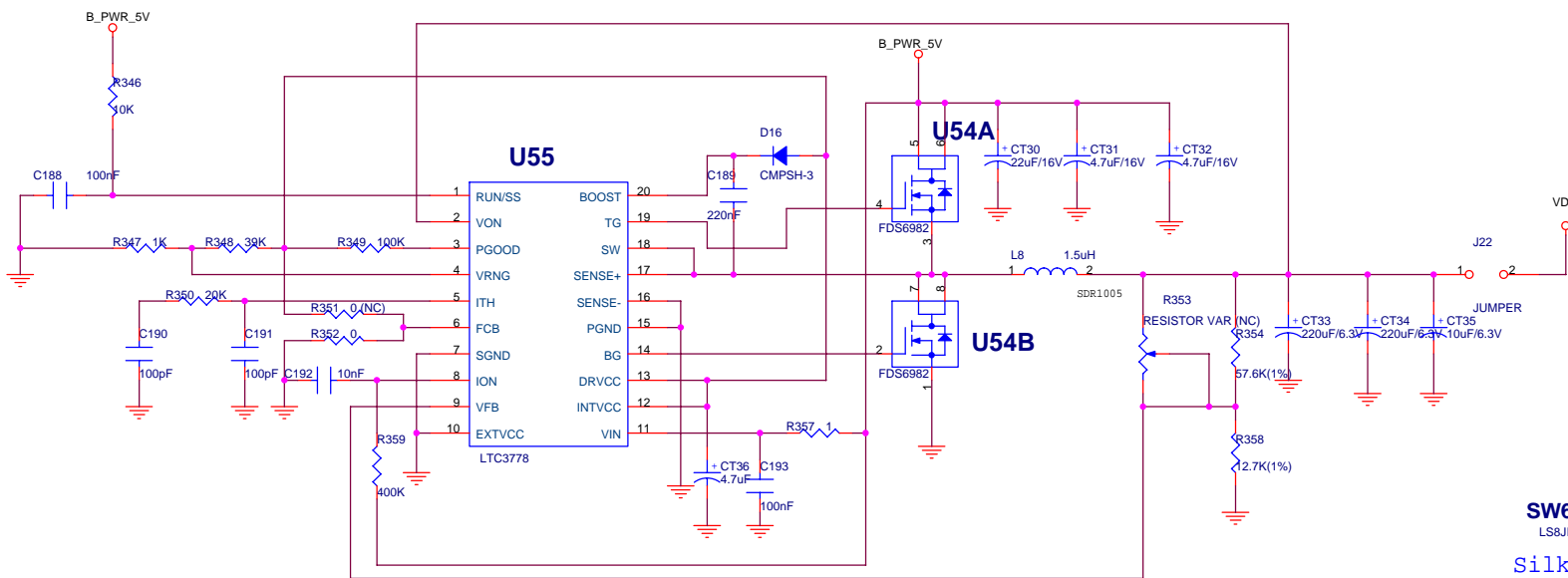
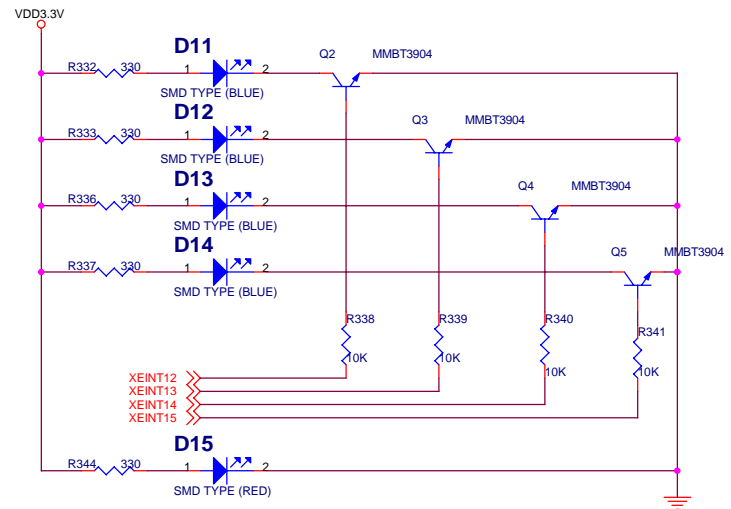
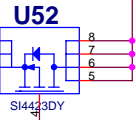
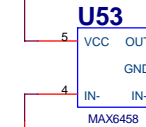
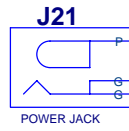

Title		
SMDK6400 (S3C6400 Evaluation Board)		
Size	Document Number	Rev
A3	Base Board Power & LED & EXINT	0.0
Date:	Thursday, December 14, 2006	Sheet 15 of 15