

# Semiconductor Components Group

Analog, Logic and Discretes

01-July-1999  
Rev. 1

Unique State Control  
Function to Implement  
Multiple On/Off Methods  
of the Power Converter

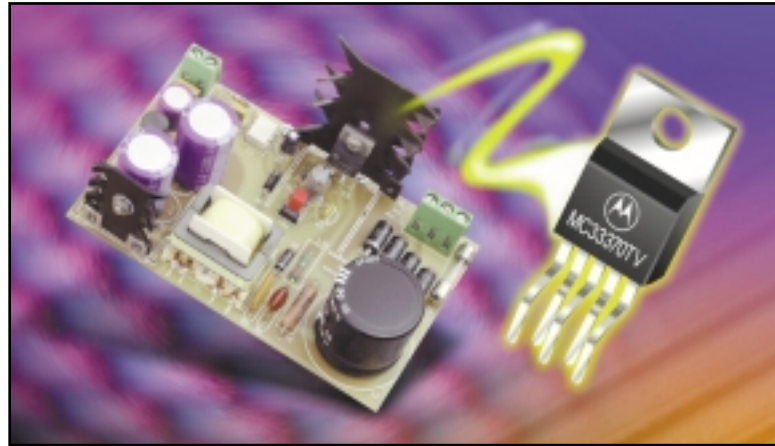

## MC33369 thru MC33374 Very High Voltage Off-Line Power Switching Regulators

### Introduction

SCG's new MC33370 series are monolithic high voltage power switching regulators that combine the required converter functions with a unique programmable state controller, allowing a simple and economical power system solution for office automation, consumer, and industrial products. These devices are designed to operate directly from a rectified AC line source and are capable of providing an output power in excess of 150 W with a fixed AC input of 100 V, 115 V, or 240 V, and in excess of 90 W with a variable AC input that ranges from 85 V to 265 V.

This device series features a programmable state controller, an on-chip 700 V SENSEFET™ power switch circuit, 700 V active off-line startup circuit, auto restart logic, fixed frequency duty cycle controlled oscillator, current limiting comparator with leading edge blanking, latching pulse width modulator for double pulse suppression, and a high gain error amplifier with a bandgap reference. Protective features include cycle-by-cycle current limiting, input undervoltage lockout with hysteresis, and thermal shutdown. These devices are available in economical five pin TO-220 and DIP-8 style packages.

## Features & Advantages

---

- ◆ Programmable State Controller to Implement 4 methods of On/Off Control of the Converter
- ◆ On-Chip 700 V SENSEFET Power Switch Circuit
- ◆ Rectified AC Line Source Operation from 85 V to 265 V
- ◆ On-Chip 700 V Active Off-Line Start-Up Circuit
- ◆ Latching PWM for Double Pulse Suppression
- ◆ Cycle-By-Cycle Current Limiting
- ◆ Input Undervoltage Lockout with Hysteresis
- ◆ Internal Thermal Shutdown
- ◆ Enhanced Functionality Over Competitive Series

## Types of Applications

---

- ◆ **Consumer Electronics:**  
Set-Top Decoders, VCRs, Small Screen TVs, DVDs, Video Games, Audio Entertainment, Satellite Receivers.
- ◆ **Office Automation:**  
Copy Machines, Faxes, Point of Sales.
- ◆ **Personal Computers:**  
Inkjet Printers, Cable Modems, External Peripherals, Multimedia Audio, Notebook AC/DC Adapters, USB Power Supply, IAPC (Instantly Available PC) Initiative- Compliant PCs, Scanners.
- ◆ **Wireless Communication:**  
Base Station of Cordless Phones, Cellular Phone AC/DC Adapters, Battery Chargers.
- ◆ **Industrial & Residential:**  
Appliances, Battery Chargers, Utility Meters, Cable Distribution, Terminals, UPS (Uninterruptible Power Supplies), Industrial Control, PFC (Power Factor Control).



## Typical Application

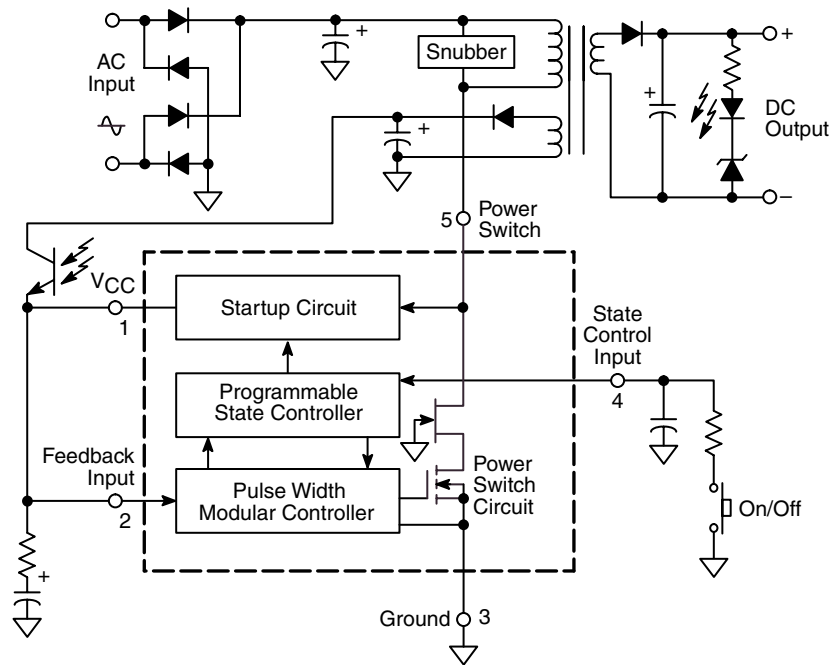

## Customer Benefits

- ◆ Simplified interface allows On/Off control by a microcontroller or other circuitry.
- ◆ Lower system cost with reduced component count for a total converter system solution.
- ◆ Improved reliability with internal thermal shutdown protection, cycle-by-cycle current limiting, and input undervoltage lockout with hysteresis.

## Key Specification Table

Device	$R_{DS(on)}$ ( $\Omega$ )	$I_{lim}$ (A)	$P_{out}$ @ $V_{in} = 92$ to $268$ VAC (W)
MC33369P	12	0.5	12
MC33370P	12	0.9	20
MC33371P	6.8	1.5	30
MC33372P	4.8	2.0	35
MC33373AP	4	2.5	40
MC33369T/TV	12	0.5	12
MC33370T/TV	12	0.9	25
MC33371T/TV	6.8	1.5	45
MC33372T/TV	4.8	2.0	60
MC33373T/TV	3.8	2.7	75
MC33374T/TV	3.0	3.3	90

# On/Off Control Methods

## 1. Primary Side Manual Toggle On/Off

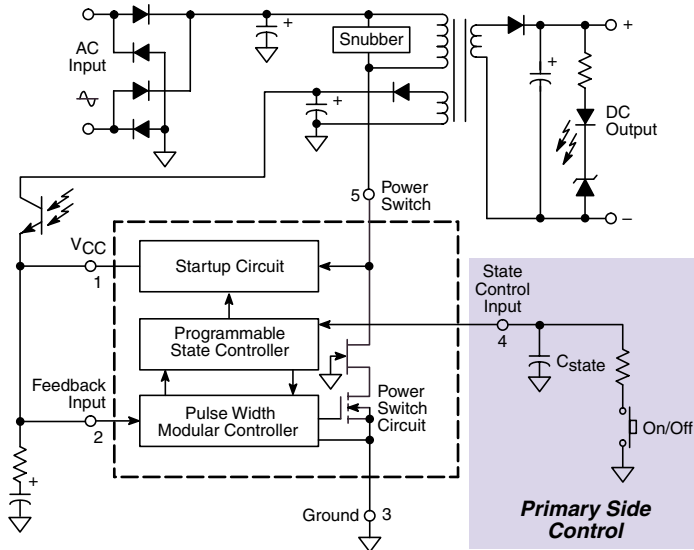

AC Line Voltage	Converter Mode	Initial State		Subsequent State	
		Input (Pin 4)		Converter Mode	Description
		C <sub>state</sub>	Stimuli		
Nominal	Standby*	Don't Care	Pulsed Low $\leq 1.8V$	Operating	The converter changes from standby* to operating mode
Nominal	Operating	Don't Care	Pulsed Low $\leq 1.8V$	Standby*	The converter changes from operating to standby* mode

\* Standby means **NO** DC output voltage on the output of the power converter

## 2. Secondary Side Microcontroller Toggle On/Off

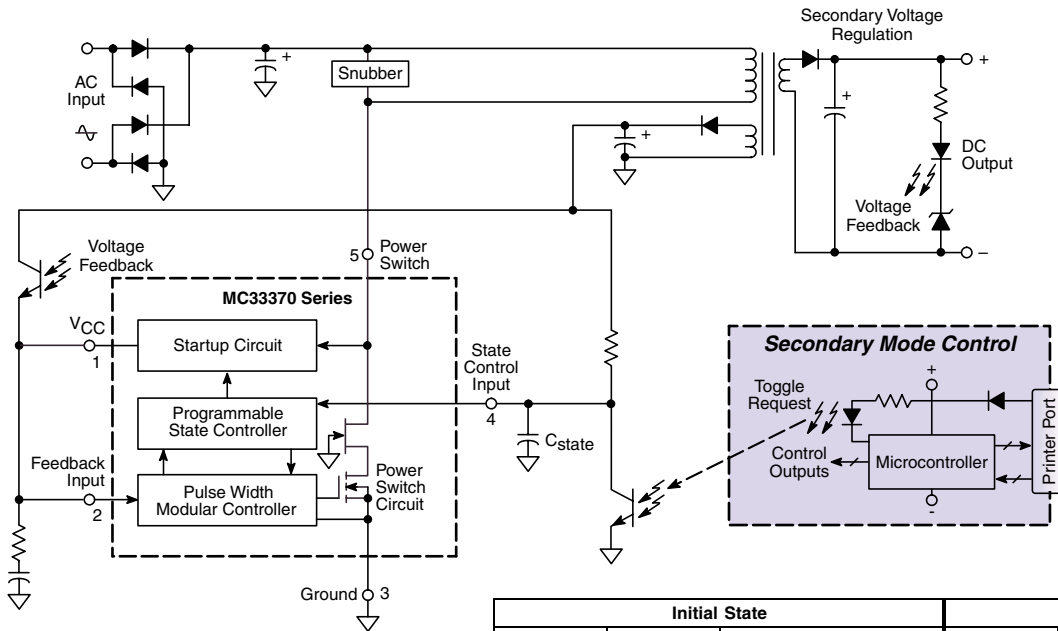

AC Line Voltage	Converter Mode	Initial State		Subsequent State	
		Input (Pin 4)		Converter Mode	Description
		C <sub>state</sub>	Stimuli		
Nominal	Standby*	Don't Care	Pulsed Low $\leq 1.8V$	Operating	The converter changes from standby* to operating mode
Nominal	Operating	Don't Care	Pulsed Low $\leq 1.8V$	Standby*	The converter changes from operating to standby* mode

\* Standby means **NO** DC output voltage on the output of the power converter



### 3. Primary Side Toggle Request with Secondary Side Microcontroller Graceful Shutdown

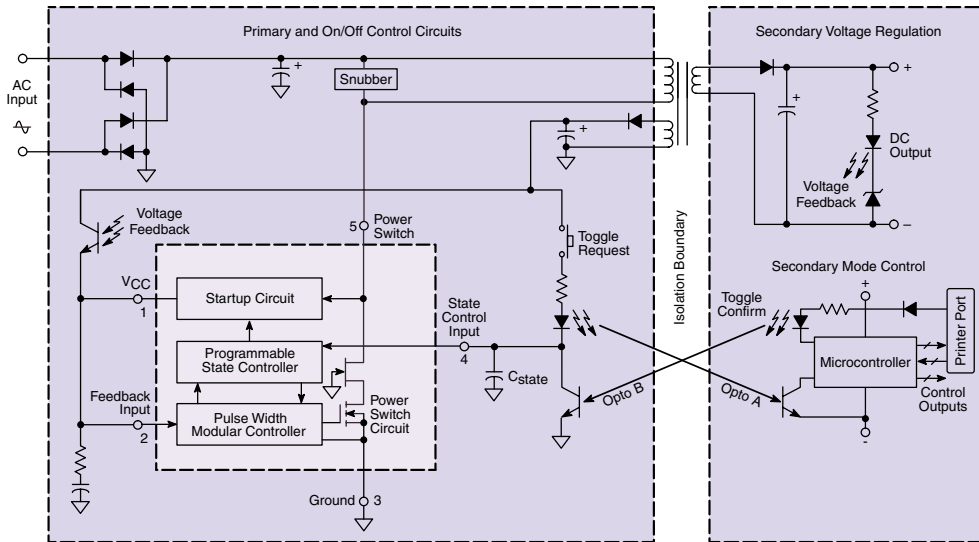

Initial State		Subsequent State			
AC Line Voltage	Converter Mode	Input (Pin 4)		Converter Mode	Description
		C <sub>state</sub>	Stimuli		
Nominal	Standby*	Don't Care	Pulsed High $\geq 4.4V$	Operating	Converter mode toggle requested. The set comparator changes the converter mode from standby* to operating mode.
Nominal	Operating	Don't Care	Pulsed High $\geq 4.4V$	Operating	Converter mode toggle requested. No mode change takes place since the converter was initially operating. The toggle request is communicated to the MCU via Opto A.
Nominal	Operating	Don't Care	Pulsed Low $\leq 1.8V$	Standby*	Upon completion of the housekeeping routine, the MCU confirms the toggle request via Opto B. The converter mode changes from operating to standby*

\* Standby means **NO** DC output voltage on the output of the power converter

### 4. Programmable On or Off State Upon Application of AC Power

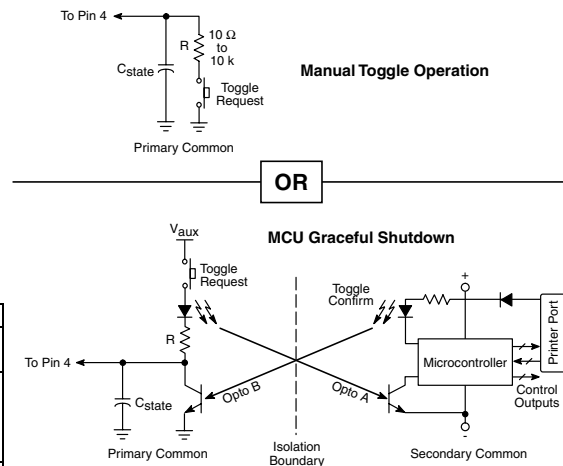
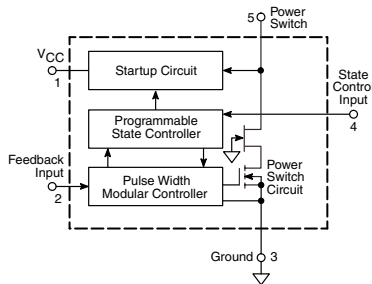

Initial State		Subsequent State			
AC Line Voltage	Converter Mode	Input (Pin 4)		Converter Mode	Description
		C <sub>state</sub>	Stimuli		
Zero to Nominal	Off	C <sub>state</sub> $\leq 0.05\mu F$	None	Operating	Application of the AC line power causes converter operation. The State Control input is presently configured to be transparent and has no effect during power-up.
Zero to Nominal	Off	C <sub>state</sub> $\geq 2.0\mu F$	Pulse Low $\leq 1.8V$ by C <sub>state</sub>	Standby*	Discharge capacitor C <sub>state</sub> causes the toggle comparator to change the control logic state. The converter is placed in the standby* mode with the power switch disabled.

\* Standby means **NO** DC output voltage on the output of the power converter

## Questions to Ask

- ◆ Are you presently designing an off-line power supply that requires lower system cost?
- ◆ Is efficiency critical to your application?
- ◆ Do you need low component count with a higher system integration level?
- ◆ Do you need a power supply where no additional circuitry is needed for on/off control?
- ◆ Are you looking for a complete power converter system solution that requires smaller circuit board space?
- ◆ Does your design require low power in standby mode?
- ◆ Are you looking for a power supply design that consumes little power while in standby mode?

## Competitive Comparison

Control Scheme	Motorola MC33370 Series	Competitor A	Competitor B	Notes
Max Power Switch Voltage	700 V	700 V	700 V	
Peak Switch Current (Typical)	0.9 to 3.3 A	0.25 to 3.0 A	4 A	1
Typical Duty Cycle Range	0.9 to 74%	1.7 to 67%	$D_{max}=50$ to 99%	2
On Resistance for Series (Typical @ $T_j=25^{\circ}\text{C}$ )	3 to 12 $\Omega$	2.6 to 15.6 $\Omega$	2.3 $\Omega$	
Control Scheme	Fixed Frequency PWM, Voltage Mode	Fixed Frequency PWM, Voltage Mode	Fixed Frequency PWM, Current Mode	
Frequency	100 kHz	100 kHz	Adjustable up to 200 kHz	
Frequency Tolerance (@ $T_j=25^{\circ}\text{C}$ )	$\pm 10\%$	$\pm 10\%$	$\pm 10\%$ @ 100 kHz	
Packaging	TO-220 5-Pin, DIP 8*	TO-220 3-Pin, DIP-8	TO-220 5-Pin, Power SO-10	
Tab Connection	TO-220 Heat Sink Connected to GND Pin	TO-220 Heat Sink Connected to GND Pin	TO-220 Heat Sink NOT Connected to GND Pin	3
Additional Features	State Control Pin for Converter On/Off	None	Synchronization Capability	4
Blue Angel Requirement	No	No	Yes	5

1. The peak current limit trip point for the MC33370 is set higher than Competitor A allowing for more power delivered to the load.
2. Warning, all converters with current mode control and operate above 50% duty cycle require slope compensation to avoid sub-harmonic oscillation. Competitor B will exhibit a sub-harmonic oscillation when operating above 50% duty cycle (i.e. maximum load and minimum line. To resolve this, Competitor B must add a minimal of 4 external components to a circuit that has already more components. Both the MC33370 and Competitor A are voltage mode and will not have sub-harmonic oscillations. The MC33370 series has a wider duty cycle operating range that allows the converter to deliver power over a wider line of voltage range.
3. In applications requiring a grounded heat sink, Competitor B requires an insulated heat sink. With a tab connected to GND, the amount of radiated noise (EMI) is less.
4. The State Control block is designed to interface with a small number of external components to implement various methods of converter on/off control. By utilizing the distinctive features of the State Control Input, this devices series can be programmed to enter into either the standby or operating mode in response to an appropriate input stimulus. The ON/OFF state control pin can be configured to interface with a microcontroller for graceful shutdown operation. Graceful shutdown is an advanced form of power management where the microcontroller has the overriding responsibility for determining if and when the converter enters into the standby mode. This is usually programmed to occur after the microcontroller completes a set of housekeeping routines. The ON/OFF state control pin can also be configured to allow the MC33370 series to be a direct replacement to Competitor A. During power failures, the ON/OFF state pin can be configured to either remain off when power is applied, or to turn on when power is applied. For details on operation of the ON/OFF state control pin, please refer to the MC33370 datasheet.
5. The blue angel requirement reflects the power consumed by the converter when no load is applied.

## Conclusion

---

A Motorola powered converter is capable of higher conversion efficiency and higher output power than the other competitive solutions. The Motorola device series offers enhanced MOSFET drive for faster transitions, higher operating temperature and a higher peak current limit that is stable over the temperature range.

Device	$R_{DS(on)}$ ( $\Omega$ )	$I_{lim}$ (A)	$P_{out}$ @ $V_{in} = 92$ to $276$ VAC (W)
<b>MC33369</b>	<b>12.0</b>	<b>0.5</b>	<b>12</b>
Competitor A, #1	21.2	0.3	7
<b>MC33370</b>	<b>12.0</b>	<b>0.9</b>	<b>25</b>
Competitor A, #2	15.6	0.5	15
<b>MC33371</b>	<b>6.8</b>	<b>1.5</b>	<b>45</b>
Competitor A, #3	7.8	1.0	30
<b>MC33372</b>	<b>4.8</b>	<b>2.0</b>	<b>60</b>
Competitor A, #4	5.2	1.5	45
<b>MC33373</b>	<b>3.8</b>	<b>2.7</b>	<b>75</b>
Competitor A, #5	3.9	2.0	60
<b>MC33374</b>	<b>3.0</b>	<b>3.3</b>	<b>90</b>
Competitor A, #6	3.1	2.5	75
Competitor A, #7	2.6	3.0	90

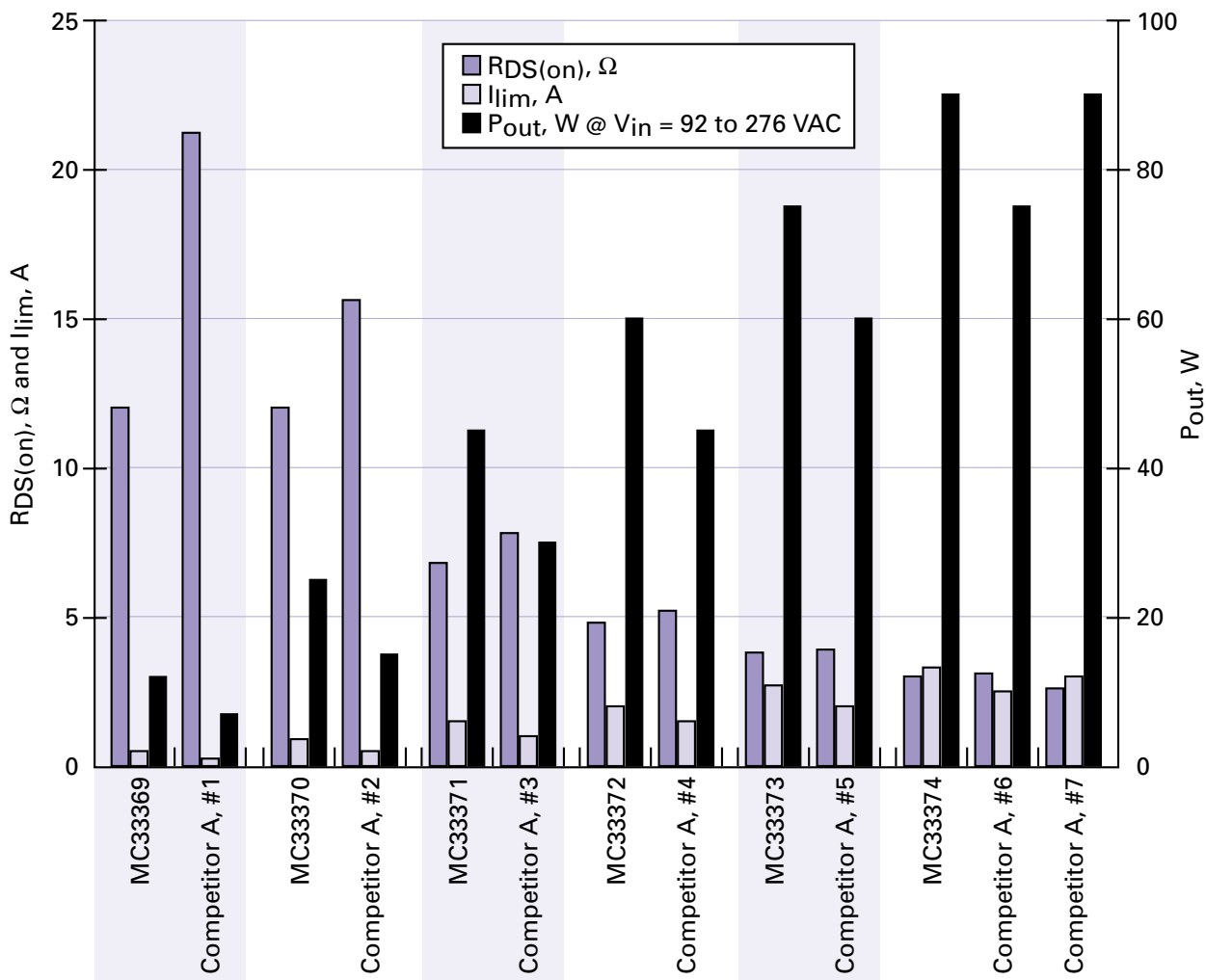



## Ordering Information

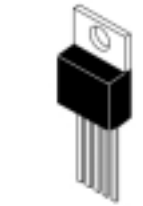

TO-220



TO-220  
(Bent Leads)



DIP-8

Device	$R_{DS(on)}$ ( $\Omega$ )	$I_{lim}$ (A)	Temperature Range	Package
MC33369T	12	0.5	-40 to +150°C	TO-220, 5-Leads
MC33369TV	12	0.5		TO-220, 5-Leads (Bent)
MC33369P	12	0.5		DIP-8
MC33370T	12	0.9	-40 to +150°C	TO-220, 5-Leads
MC33370TV	12	0.9		TO-220, 5-Leads (Bent)
MC33370P	12	0.9		DIP-8
MC33371T	6.8	1.5	-40 to +150°C	TO-220, 5-Leads
MC33371TV	6.8	1.5		TO-220, 5-Leads (Bent)
MC33371P	6.8	1.5		DIP-8
MC33372T	4.8	2.0	-40 to +150°C	TO-220, 5-Leads
MC33372TV	4.8	2.0		TO-220, 5-Leads (Bent)
MC33372P	4.8	2.0		DIP-8
MC33373T	3.8	2.7	-40 to +150°C	TO-220, 5-Leads
MC33373TV	3.8	2.7		TO-220, 5-Leads (Bent)
MC33373AP	4.0	2.7		DIP-8
MC33374T	3.0	3.3	-40 to +150°C	TO-220, 5-Leads
MC33374TV	3.0	3.3		TO-220, 5-Leads (Bent)

\* MC33369 devices are only available in sample quantities. Production quantities will be available in 2Q99.

\*\* DIP-8 packages are only available in sample quantities. Production quantities will be available in 1Q99.

## Literature

A data sheet containing full specifications is available as **MC33370/D**. See the last page for detailed information on how to obtain technical literature.

## Lead Times & Pricing

All products are currently available in production quantities. Pricing in 10K quantities starts at \$0.85.

PRODUCT BULLETIN • PRODUCT BULLETIN • PRODUCT BULLETIN • PRODUCT BULLETIN •

# How to Obtain Technical Literature

---

There are several ways to obtain SCG's Technical Literature and Publications. Below you will find a list of methods to contact our Literature Distribution Center (LDC). If you need any assistance, or if you are having difficulty contacting LDC, please email us in the SCG Marketing Communications Group at: SCGMKTG1@email.sps.mot.com or call us at 602-244-3882.

◆ **Literature Distribution Center**, Americas

- From US & Canada Only (Toll free) **1-800-441-2447**, email: ldcformotorola@hibbertco.com
- From All Other Global Locations **1-303-675-2140**
- CD-ON-DEMAND, Literature Ordering <http://merchant.hibbertco.com/mtrl> (Motorolans, Distributors & Partners)

◆ **Literature Search Website**

<http://sps.motorola.com/cgi-bin/dlsrch>

◆ **Asia/Pacific**

(US Based Support for A/P)

**852-2662-9298**, email: ldcformotorola-asia@hibbertco.com

**1-303-675-2130** (Tue-Fri 9:00am to 1:00pm, Hong Kong Time)

◆ **Motorola Mfax™ Fax-Back System**

- From US & Canada Only (Toll free) **1-800-774-1848**, email: RMFAX0@email.sps.mot.com
- From All Other Global Locations **1-602-244-6609**

◆ **SCG Home Page**

<http://scgtomorrow.motorola.com>

DigitalDNA, Mfax, MOSFET, SENSEFET and SMARTMOS are trademarks of Motorola, Inc.

*All brand names and product names appearing in this publication are registered trademarks or trademarks of their respective holders.*

SCG reserves the right to make changes without further notice to any products herein. SCG makes no warranty, representation or guarantee regarding the suitability of its products for any particular purpose, nor does SCG assume any liability arising out of the application or use of any product or circuit, and specifically disclaims any and all liability, including without limitation consequential or incidental damages. "Typical" parameters which may be provided in SCG data sheets and/or specifications can and do vary in different applications and actual performance may vary over time. All operating parameters, including "Typicals" must be validated for each customer application by customer's technical experts. SCG does not convey any license under its patent rights nor the rights of others. SCG products are not designed, intended, or authorized for use as components in systems intended for surgical implant into the body, or other applications intended to support or sustain life, or for any other application in which the failure of the SCG product could create a situation where personal injury or death may occur. Should Buyer purchase or use SCG products for any such unintended or unauthorized application, Buyer shall indemnify and hold SCG and its officers, employees, subsidiaries, affiliates, and distributors harmless against all claims, costs, damages, and expenses, and reasonable attorney fees arising out of, directly or indirectly, any claim of personal injury or death associated with such unintended or unauthorized use, even if such claim alleges that SCG was negligent regarding the design or manufacture of the part. SCG is an Equal Opportunity/Affirmative Action Employer.

**How to reach us:**

**Publications and Literature Fulfillment:** Motorola Literature Distribution;  
P.O. Box 5405, Denver, Colorado 80217. 1-303-675-2140 or 1-800-441-2447

**SCG Website:** <http://scgtomorrow.motorola.com>

**For Additional Information, Please Contact Your  
SCG Sales Representative**

**Customer Focus Center:** 1-800-521-6274