

INTERNATIONAL
STANDARD

ISO
9141-2

First edition
1994-02-01

Road vehicles — Diagnostic systems —
Part 2:
CARB requirements for interchange of digital
information

Véhicules routiers — Systèmes de diagnostic —
Partie 2: Caractéristiques CARB de l'échange de données numériques

0



Reference number
ISO 9141-2:1994(E)

Contents

	Page
1 Scope	1
2 Normative references	1
3 Definitions	1
4 Specific configurations	1
5 Signal and communication specifications	2
6 Initialization of vehicle prior to serial communication	3
7 Initialization header	4
8 Requirements of diagnostic tester	6
9 Requirements of ECU	6
10 Requirements of wiring	7
11 Subsequent communication protocol	7
12 Message timing	9
13 Error handling	9
14 Worked example	10

Annex

A Tables of initialization, header and protocol timings, and electrical characteristics	13
---	----

© ISO 1994

All rights reserved. No part of this publication may be reproduced or utilized in any form or by any means, electronic or mechanical, including photocopying and microfilm, without permission in writing from the publisher.

International Organization for Standardization
Case Postale 56 • CH-1211 Genève 20 • Switzerland
Printed in Switzerland

Foreword

ISO (the International Organization for Standardization) is a worldwide federation of national standards bodies (ISO member bodies). The work of preparing International Standards is normally carried out through ISO technical committees. Each member body interested in a subject for which a technical committee has been established has the right to be represented on that committee. International organizations, governmental and non-governmental, in liaison with ISO, also take part in the work. ISO collaborates closely with the International Electrotechnical Commission (IEC) on all matters of electrotechnical standardization.

Draft International Standards adopted by the technical committees are circulated to the member bodies for voting. Publication as an International Standard requires approval by at least 75 % of the member bodies casting a vote.

International Standard ISO 9141-2 was prepared by Technical Committee ISO/TC 22, *Road vehicles*, Sub-Committee SC 3, *Electrical and electronic equipment*.

ISO 9141 consists of the following part, under the general title *Road vehicles* — *Diagnostic systems*:

— *Part 2: CAB requirements for interchange of digital information.*

NOTE — ISO 9141:1989, *Road vehicles* — *Diagnostic systems* — *Requirements for interchange of digital information*, is regarded as being part 1 of this International Standard.

Annex A forms an integral part of this part of ISO 9141.

Road vehicles — Diagnostic systems —

Part 2: CARB requirements for interchange of digital information

1 Scope

This part of ISO 9141 describes a subset of ISO 9141:1989. It specifies the requirements for setting up the interchange of digital information between on-board emission-related Electronic Control Units (ECUs) of road vehicles and the SAE OBDII scan tool as specified in SAE J1978. This communication is established to facilitate compliance with California Code of Regulation, Title 13, 1968.1, *Malfunction and Diagnostic Systems Requirements, 1994 and subsequent model year passenger cars, light-duty trucks, and medium duty vehicles with feedback fuel control systems*.

This part of ISO 9141 is limited to vehicles with nominal 12 V supply voltage.

2 Normative references

The following standards contain provisions which, through reference in this text, constitute provisions of this part of ISO 9141. At the time of publication, the editions indicated were valid. All standards are subject to revision, and parties to agreements based on this part of ISO 9141 are encouraged to investigate the possibility of applying the most recent editions of the standards indicated below. Members of IEC and ISO maintain registers of currently valid International Standards.

ISO 7637-1:1990, *Road vehicles — Electrical disturbance by conduction and coupling — Part 1: Passenger cars and light commercial vehicles with nominal 12 V supply voltage — Electrical transient conduction along supply lines only*.

ISO 9141:1989, *Road vehicles — Diagnostic systems — Requirements for interchange of digital information*.

SAE J1962, *Diagnostic Connector*.

SAE J1978, *OBD II Scan Tool*.

SAE J1979, *E/E Diagnostic Test Modes*.

SAE J2012, *Format and Messages for Diagnostic Trouble Codes*.

California Code of Regulation, Title 13, 1968.1, *Malfunction and Diagnostic Systems Requirements*.

3 Definitions

For the purposes of this part of ISO 9141, the definitions given in ISO 9141 apply.

4 Specific configurations

4.1 Vehicle ECUs required by OBD II to communicate with the SAE J1978 OBD II scan tool shall support either a one-wire (K line only) or a two-wire (K and L line) communication connection to the SAE J1978 OBD II scan tool through the SAE J1962 diagnostic connector. Vehicle battery voltage, V_b , power ground and signal ground shall be provided by ECUs or the vehicle to the SAE J1962 diagnostic connector. Pin assignment of the diagnostic connector shall be in accordance with SAE J1962.

Line K is a bidirectional line. It is used during initialization to convey address information from the diagnostic tester to vehicle ECUs, simultaneously with the line L. After conveying the address, the K line is used to convey bidirectional data between vehicle ECUs and the diagnostic tester to complete initialization. After initialization, it is used to convey request messages from the diagnostic tester to vehicle ECUs and response messages from the vehicle ECUs to the diagnostic tester.

Line L is a unidirectional line and is only used during initialization to convey address information from the diagnostic tester to vehicle ECUs, simultaneously with the K line. At all other times it should idle in the logic "1" state.

Figure 1 shows the system configurations indicating the role of each of the communication lines K and L.

5 Signal and communication specifications

5.1 Signal

For proper operation of the serial communication, both ECU and diagnostic tester shall correctly determine each logic state as follows:

— a logic "0" is equivalent to a voltage level on the line of less than 20 % V_B for transmitter, 30 % V_B for receiver;

— a logic "1" is equivalent to a voltage level on the line of greater than 80 % V_B for transmitter, 70 % V_B for receiver.

4.2 If any ECUs, either of one type or in combination, are linked on a bus, the system designer shall ensure that the configuration is capable of correct operation. For example, data from one ECU shall not initialize the serial communication of another ECU on the bus and an initialization signal shall not cause more than one ECU to respond simultaneously; it may, however, initialize a number of ECUs on the bus which then respond in an orderly sequential manner.

If lines K and L are used for purposes other than inspection, test and diagnosis, care shall be taken to avoid data collision and incorrect operation in all modes.

In addition, the slope times shall be less than 10 % of the bit time. The slope times are defined as the time taken for the voltage to change from 20 % to 80 % V_B , and from 80 % to 20 % V_B for transmitters. Voltage levels between 30 % and 70 % of V_B may be detected as either logic "1" or logic "0". NRZ (Non-Return-to Zero) coding shall be used. The bit time is defined as half of the time between the 50 % V_B levels of successive rising or falling edges of alternating "1" and "0" bits.

Figure 2 illustrates the worst case on signal levels. For electrical specifications of diagnostic testers, see 8.3 and of ECUs, see 9.2.

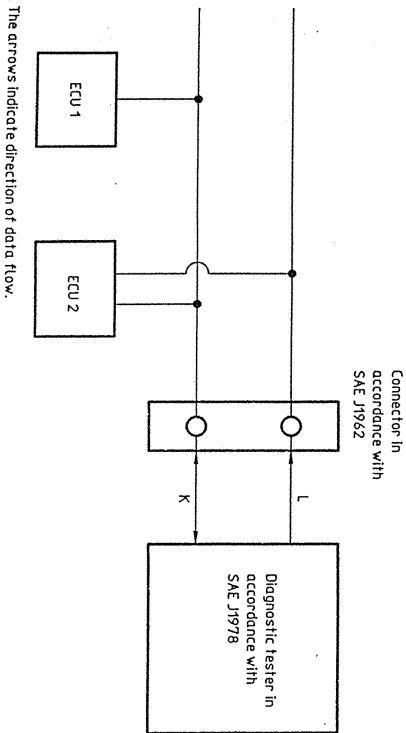

Figure 1 — Possible system configuration

5.2 Communication specification

5.2.1 The configuration is shown schematically in figure 3.

5.2.2 The capacitance contribution of the diagnostic tester according to SAE J1978 and the cables are termed C_{TE} . The capacitance contribution of the on-board wiring is termed C_{Gaw} . The sum of the input capacitances of all ECUs on the bus is defined thus:

$$C_{ECU} = \sum_{i=1}^n C_{ECU_i}$$

where n is the number of ECUs on the bus.

Values for C_{ECU} and C_{Gaw} shall be selected such that

$$C_{ECU} + C_{Gaw} \leq 7,6 \text{ nF}$$

and

$$C_{TE} \leq 2 \text{ nF}$$

These values are derived from the maximum communication speed (see clause 8) and the circuit resistance (see clause 9).

6 Initialization of vehicle prior to serial communication

The time periods referred to in this clause shall be as defined in tables A.1 and A.2.

In order to communicate with the diagnostic tester, the initialization shall be achieved by transmission of a 5-bit/s address by the diagnostic tester to the vehicle which shall comprise a single byte constructed as shown in figure 4, making an 8-bit address on lines K and L.

In order to invoke communication in the format described in clause 11, the address shall be 33_H. Other addresses may produce responses according to the vehicle manufacturer's definition or future standardization.

Before the initialization, the line K shall be logic "1" for the time period W_0 .

Each address byte shall consist of

- a) one start bit — logic "0" for one bit duration;
- b) 8 bits, the least significant bit (LSB) being sent first;
- c) one stop bit — logic "1" for one bit duration.

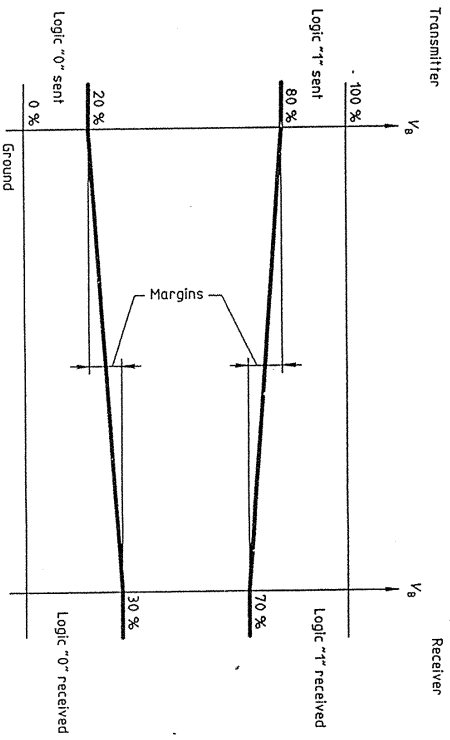

Figure 2 — Signal voltage levels, worst-case values

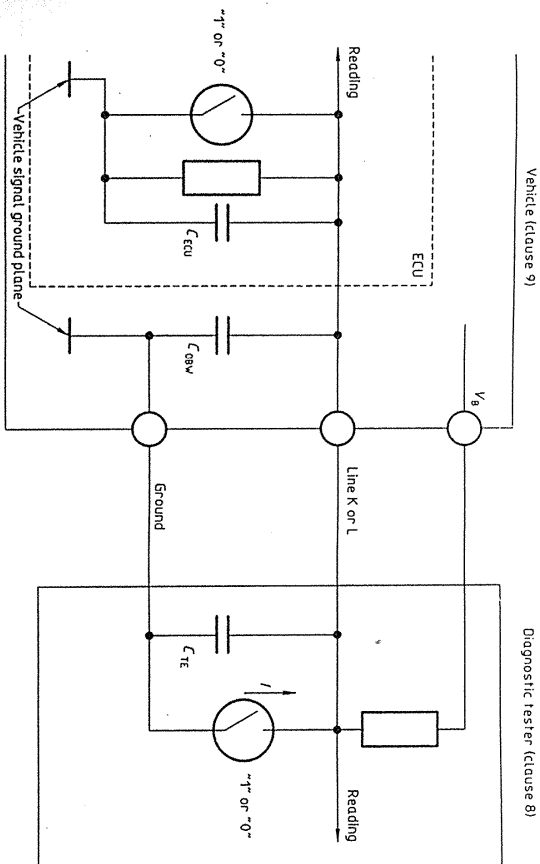

Figure 3 — Vehicle signal ground plane

7 Initialization header

The time periods referred to in this clause shall be as defined in tables A.1 and A.2.

7.1 Purpose

The main purpose of this header construction is to maintain compatibility with existing diagnostic systems according to ISO 9141.

7.2 Transmission of speed synchronization pattern

Before transmitting the synchronization pattern, Line K shall be logic "1" for the time period T_1 .

This pattern informs the diagnostic tester of the baud rate for transmission of the key words and all subsequent data. It shall consist of

a) one start bit — logic "0" for one bit duration;

b) 8 alternate bits starting with a logic "1" bit;

c) one stop bit — logic "1" for one bit duration;

d) logic "1" for the time period T_2 in order to allow the diagnostic tester to reconfigure.

7.3 Key word format

After the transmission of the speed synchronization pattern, two key words shall be transmitted to inform the diagnostic tester of the form of the subsequent serial communication and of the hardware configuration of the diagnostic lines. Each key word shall consist of

a) one start bit — logic "0" for one bit duration;

b) seven bits, the least significant bit (LSB) being sent first;

c) one parity such that the number of logic "1" bits in the byte containing the seven key bits and the said parity bit is an odd number;

d) one stop bit — logic "1" for one bit duration.

The format is shown in figure 5.

The values of the key words are shown in figure 6 and defined in clause 12.

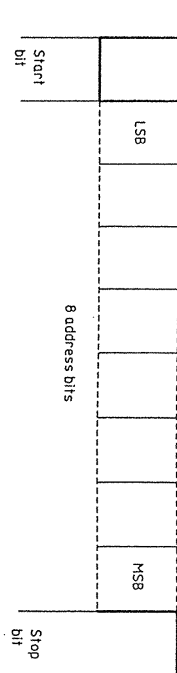

Figure 4 — Initialization format

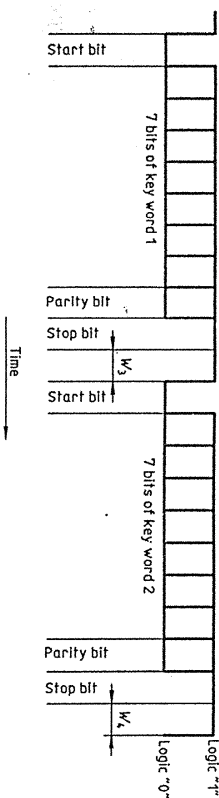
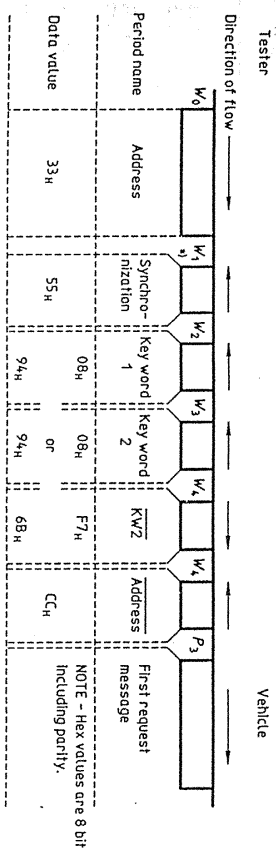

Figure 5 — Key word format



$W_0 \geq 2 \text{ ms}$
 $60 \text{ ms} \leq W_1 \leq 300 \text{ ms}^*)$
 $5 \text{ ms} \leq W_2 \leq 20 \text{ ms}$
 $0 \leq W_3 \leq 20 \text{ ms}$
 $25 \text{ ms} \leq W_4 \leq 50 \text{ ms}$

see also table A.1

*) W_1 min. (60 ms) is measured from the end of the address byte (33H) stop bit. The minimum value is based on a combined tester (+1%) and ECU (-2%) tolerance on the receipt of the address byte (3% of 2 s = 60 ms).
 Vehicle designers should note that this value does not include any factor for tolerances related to bit sampling frequencies.

Figure 6 — Header

7.3.1 After the final key word transmitted by the ECU and within a standard time interval W_4 , the tester shall transmit the logic inversion of the final key word for hand-shaking purposes.

After this and within a standard time interval W_4 , the ECU shall transmit the logic inversion of the initializing address.

7.3.2 Multiple values for P_2 , the interval between a request message and the first response and the interval between each subsequent response, are defined in clause 12. The selection of which P_2 value applies to a given communication sequence is determined by the key word transmitted by a vehicle ECU. For further information, see clause 12.

7.4 Time requirements

W_0 to W_4 shall be as shown in figure 6.

8 Requirements of diagnostic tester

8.1 Standard connector

The connector shall be compatible with the vehicle connector as specified by SAE J1962.

8.2 Minimum functional capabilities

The diagnostic tester shall be capable of

- supporting initialization and header (as in clauses 6 and 7);
- providing an initialization, simultaneously on the K and L lines;
- the address to be transmitted at 5 bits \pm 0.5 %;
- reading the transmission rate synchronization pattern;
- reading key words;
- transmitting the logic inversion of the final key word read;
- reading the logical inversion of the initializing address;

h) supporting the transmission and reception of the message protocol defined in SAE J1979, with the modification shown in clause 11;

i) supporting the requirements defined in SAE J1978.

8.3 Electrical specifications

These specifications shall apply over a working temperature range of 0 °C to 50 °C.

The following specifications shall apply to nominal 12 V systems for which the diagnostic tester shall operate correctly in the range 8 V to 16 V of vehicle battery voltage V_b .

Manufacturers of diagnostic testers are encouraged to extend the limits of correct operation for vehicle battery voltage V_b and working temperature.

8.3.1 For lines K and L of the diagnostic tester not connected to an ECU, each line shall be internally pulled up to V_b via a nominal 510 Ω resistor.

Transmission state

At logic "1" the diagnostic tester shall have an equivalent voltage source greater than 90 % V_b sourced from the vehicle positive voltage V_b , and an equivalent resistance of 510 $\Omega \pm$ 5 %.

At logic "0" the diagnostic tester shall have an equivalent voltage of less than 10 % of V_b , at a maximum sink current of 2 A.

Receiving state

The equivalent resistance of the line K of the diagnostic tester shall be 510 $\Omega \pm$ 5 %.

8.3.2 The transmission rate shall be 10.4 kbits \pm 1 %.

8.3.3 For each byte, the diagnostic tester shall be capable of determining the status of any bit, the transitions of which are shifted by not more than 30 % of the bit time relative to their calculated position in time.

8.3.4 The diagnostic tester shall not transfer to the open lines K and L any voltage higher than V_b , or any voltage lower than -1 V. This includes suppressions of voltage excursion of V_b as detailed in ISO 7637-1.

8.3.5 The diagnostic tester shall expect a resistance of at least 5 k Ω to vehicle signal ground and at least 10 k Ω to V_b on K and L lines when connected to the vehicle.

8.3.6 The total capacitance of the diagnostic tester, its cable and connector, C_{TE} , shall not exceed 2 nF.

9 Requirements of ECU

9.1 Input and output lines

ECUs shall have one (K) or two (K and L) connections as specified in 4.1.

9.2 Electrical specifications

9.2.1 Line K

At logic "1", or in receiving state, the ECU shall behave like a resistance to ground of at least 50 k Ω . If an internal resistor is used between line K and V_B , its value shall not be less than 100 k Ω . The capacitance of line K with respect to ground of each ECU should not exceed 500 pF. In case of problems (e.g. with EMI) the car manufacturer's system designer may choose a different specification, but attention shall be paid to the maximum value of the capacitance of the vehicle, which is given by the summation of C_{OBW} and C_{ECU} . This value shall not exceed 7,6 nF (see 5.2.2).

At logic "0" the ECU shall have an equivalent sink resistance of not more than 110 Ω between line K and ground. In addition the sink resistance shall be designed so that the slope time of the falling edge is as in 5.1. When the serial communication of the ECU is not in operation and the diagnostic tester is connected, the output of the ECU shall be at logic "1".

9.2.2 Line L

The input resistance to ground shall not be less than 50 k Ω . If an internal resistor is used between line L and V_B , its value shall not be less than 100 k Ω .

The capacitance of line L with respect to ground of each ECU should not exceed 500 pF (see 9.2.1).

9.2.3 Lines K and L

The input/output circuitry of the ECUs shall withstand transitions and overvoltage present on the diagnostic tester lines K and L via the diagnostic tester source resistance.

The K and L lines shall withstand:

20 V d.c. permanently,

24 V d.c. for 30 min,

30 V d.c. for 1 min,

and, in accordance with ISO 7637-1,

test pulse 3a with $V_s = -14,5$ V, and

test pulse 3b with $V_s = +27,5$ V,

both values referred to $U_A = 13,5$ V.

9.3 Minimum functional capabilities

The ECU shall be capable of receiving the 5 bit/s initialization address on either or both K and L lines. The ECU shall be capable of supporting the header and subsequent communication at 10,4 kbit/s. The tolerance on all transmission speeds shall be ± 2 %.

10 Requirements of wiring

The capacitance of each serial communication line, C_{OBW} , built into the vehicle shall not exceed 2 nF with respect to vehicle signal ground, when measured with no ECU connected. V_B and the ground shall also be made available to the diagnostic tester but need not come directly from an ECU.

11 Subsequent communication protocol

This protocol applies only to those diagnostic links defined in the previous clauses and is invoked by address 33_H. Other messages and message structures are allowed on these links according to the vehicle manufacturer's definition, which may be invoked by using different addresses. If address 33_H is used, the messages used by vehicle manufacturers shall neither conflict with SAE J1979 messages nor disrupt communication with diagnostic testers conforming to SAE J1978.

11.1 OBD II communications

OBD II emission-related communications consist of messages of between 5 and 11 bytes.

Sequence and descriptions shall be as specified in table 1.

The data values shown in columns 1 and 2 of table 1 are examples. SAE J1979 should be referenced to confirm the actual values required.

Column 1 lists the byte values for request messages from the diagnostic tester to the vehicle.

Column 2 lists the byte values for response messages from the vehicle to the diagnostic tester.

During transmission a byte shall consist of a start bit (logic "0"), 8 data bits transmitting the least significant bit (LSB) first, and one stop bit (logic "1") (see figure 7).

11.2 Checksum definition

11.2.1 The checksum byte (CS) inserted at the end of the message block (see figure 8) is defined as the simple 8-bit sum series of all the bytes in the message, excluding the checksum.

11.2.2 The CS calculation is as follows.

If the message is:

$$\langle 1 \rangle \langle 2 \rangle \langle 3 \rangle \dots \langle N \rangle , \langle CS \rangle$$

where $\langle i \rangle$ ($1 \leq i \leq N$) is the numeric value of the i^{th} byte of message, then:

$$\langle CS \rangle = \langle CS \rangle_N$$

where $\langle CS \rangle_i$ ($i = 2$ to N) is defined as
 $\langle CS \rangle_i = \{ \langle CS \rangle_{i-1} + \langle i \rangle \} \text{ Modulo } 256$
 and $\langle CS \rangle_1 = \langle 1 \rangle$.

11.3 Number, type and content of messages
 The number, type and content of messages for each data byte are as in SAE J1979 except for the differences defined in 11.1 and 11.2.

Table 1 — Message structure

Sequence	Description	Column 1	Column 2	Reference
Byte 1	Message header 1	6B _H	4B _H	SAE J1979
Byte 2	Message header 2	6A _H	6B _H	SAE J1979
Byte 3	Source address	F1 _H	Address	SAE J1979
Bytes 4 to 10	Data (up to 7 bytes)	XX _H	XX _H	SAE J1979
Final byte	Checksum	YY _H	YY _H	see 11.2

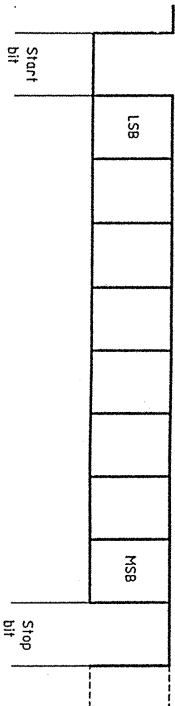

Figure 7 — Byte format

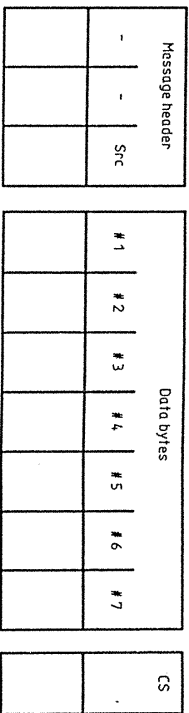

Figure 8 — Message block

11.4 Fault codes

Fault codes shall be as defined in SAE J2012.

12 Message timing

Figure 9 specifies the interbyte and intermessage timing parameters.

The P_1 to P_4 parameters are defined as follows:

P_1 is defined as the period between the completion of the stop bit of one byte of a message sent by the vehicle and the first edge of the start bit of the next byte.

P_2 is defined as the period between the completion of the stop bit of the last byte of a message and the first edge of the start bit of the next message. These messages may be the request from the tester and the first vehicle response respectively, or multiple vehicle responses to the same request. If the message synchronization is achieved only by timing, then P_2 min. shall be 25 ms and key words 08h 08h shall be used. If another type of message synchronization is provided, then P_2 min. shall be 0, and key words 94h 94h shall be used.

P_3 is defined as the period between the trailing edge of the last bit of the final vehicle response to

one diagnostic tester message and the first edge of the start bit of the first byte of a subsequent diagnostic tester message.

P_4 is defined as the period between the completion of the stop bit of one byte of a message sent by the tester and the first edge of the start bit of the next byte.

13 Error handling

13.1 Initialization

In the event of a fault being detected during the initialization or header sequence, either by the maximum value of W_1 , W_2 , W_3 , or W_4 being exceeded or by the appearance of errors in the bit stream, then the diagnostic tester will wait for the time period W_5 (see table A.1) before beginning to transmit the initialization address again.

If an ECU detects an error as described above, the ECU will immediately be prepared to recognize the initialization address.

There is no requirement to detect whether the times are less than the minimum values of W_1 , W_2 , W_3 or W_4 . Bit pattern corruptions possibly caused by such small times are treated as above.

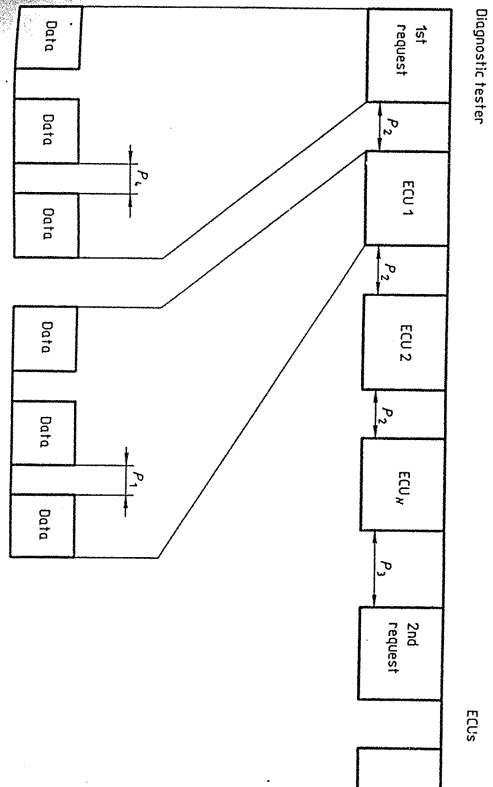

The values of P_1 to P_4 shall be as in table A.2.

Figure 9 — Interbyte and intermessage timing

13.2 Subsequent communication

For timings, see clause 12.

There are a number of detectable errors, as shown individually below, and in some cases an error detected by one of the communicators will be handled by generating an error detectable by the other but of a different type.

If the diagnostic tester detects an error, it will continue to retry until 1 min has elapsed since the last valid response.

After this time it is assumed that the serial link will require initialization as described in clauses 6 and 7.

13.2.1 Checksum incorrect

If the vehicle has detected a checksum error, then it shall respond in one of the two ways:

- as defined in SAE J1979 for incorrect CRC values in request and response messages, respectively;
- send no response — in which case the diagnostic tester will detect an error as described in 13.2.4 and retransmit the original request.

If the diagnostic tester has detected an error in a response message then it shall retransmit the original request message. The tester shall expect to receive a message up to P_3 min. after the end of the last response.

13.2.2 Message structure incorrect

If the vehicle has detected a message structure error (i.e. incorrect message header information; out-of-range mode, PID or data values; short or long message length), it shall respond as in responding to a checksum error.

If the diagnostic tester has detected a similar problem, it shall again treat the error as a checksum error.

13.2.3 Interbyte timing incorrect

This refers to periods P_1 and P_4 (see clause 12).

It is not required that periods less than the minimum value shown be detected as an error. However, if the interbyte timing is too short, then this may lead to other errors as defined in this clause, in which case the tester and the vehicle shall respond accordingly.

If this period is too long, then this shall be treated as an end-of-message marker with the last byte being treated as the checksum, so causing either a checksum error or a message structure error.

13.2.4 Vehicle response period incorrect

This refers to period P_2 in figure 9.

If the period is too short, the diagnostic tester may not receive the correct response and either a message structure error or a checksum error shall be generated.

If the period is too long, then the diagnostic tester shall retransmit the original message.

13.2.5 Vehicle response to next diagnostic tester message period incorrect

This refers to period P_3 in figure 9.

If the period is too short, then the vehicle may not receive the message correctly and in this case either a message structure error or checksum error shall be generated.

If this period is too long, then the vehicle shall assume that communication is over and shall subsequently require complete reinitialization.

It is therefore recommended that if the diagnostic tester is aware that a prolonged communication will may take place (e.g. while awaiting a human response), then it should periodically transmit "dummy" messages.

14 Worked example

The following example shows the operation of this part of ISO 9141 on a vehicle fitted with two ECUs which have CARB-related data. See figure 10.

- Time 1: Diagnostic tester transmits "33H" at 5 bits on both K and L lines.
- Time 2: Both ECU 1 and ECU 2 wake up, ECU 2 listens only, ECU 1 prepares to transmit SYNC pattern at 10,4 kbit/s, diagnostic tester prepares to receive.
- Time 3: ECU 1 transmits "55H" at 10,4 kbit/s, diagnostic tester receives.
- Time 4: ECU 1 prepares to transmit first key word.
- Time 5: ECU 1 transmits first key word "08H", diagnostic tester receives key word "08H".
- Time 6: ECU 1 prepares to transmit second key word.
- Time 7: ECU 1 transmits second key word "08H", diagnostic tester receives second key word, diagnostic tester sets P_2 min. to 25 ms.

- Time 8: Diagnostic tester prepares to send acknowledgement in the form of the logic inversion of the last key word.
- Time 9: Diagnostic tester transmits "F7H" (the 8-bit logical inversion of "08H").
- Time 10: ECU 1 prepares to transmit "Ready to communicate" signal in terms of the logic inversion of the address.
- Time 11: ECU 1 transmits "CCH".
- Time 12: Diagnostic tester prepares to send its first request message.
- Time 13: Diagnostic tester transmits message one, a model(1) PID(0) request for supported PID values from all CARB-related ECUs. The minimum interbyte spacing for this and all messages from the tester is a value of 5 ms (P_4).
- Time 14: ECU 1 and ECU 2 time out to ensure End-of-Message, ECU 1 prepares response.
- Time 15: ECU 1 transmits a 10 byte model(1) response to the PID(0) request. The minimum interbyte spacing for this and all messages from the vehicle is a value of 0 ms (P_7). The response notifies support of the following PIDs: 1, 2, 5, 7, 8, 10, 13, 14, 16, 19, 21.
- Time 16: ECU 2 times out to ensure end of ECU 1 response and prepares its own response.
- Time 17: ECU 2 transmits a 10 byte model(1) response to the PID(0) request. The response notifies support of the following PIDs: 1, 2, 4, 7, 9, 12, 13, 17, 20.
- Time 18: Diagnostic tester times out to ensure end of vehicle response, prepares next message.
- Time 19: Diagnostic tester transmits message two, a model(1) PID(1) request for diagnostic system status.
- Time 20: ECU 1 and ECU 2 time out to ensure end of message, ECU 1 prepares response.
- Time 21: ECU 1 transmits an 8 byte model(1) response to the PID(1) request. The response notifies the tester of one recorded trouble code and confirms the execution and completion of all eight diagnostic tests, and that ECU 1 is activating the MIL.
- Time 22: ECU 2 times out to ensure end of ECU 1 response, and prepares its own response.
- Time 23: ECU 2 transmits an 8 byte model (1) response to PID (1) request. The response states no trouble codes, all diagnostic test complete, and ECU 2 is not activating the MIL.

Time	1	2	3	4	5	6	7	8	9	10	11	12
Source	Tester	W_1	Vehicle (ECU 1)	W_2	Vehicle (ECU 1)	Vehicle (ECU 2)	Tester	W_4	Tester	W_4	Vehicle (ECU 1)	
Parameter	Address 33 _H		SYNC 55 _H		Key word 1 08 _H		Key word 2 08 _H		K_2	F'_{1H}	Address CC _H	

Time	13	14	15	16	17	18	19	20	21	22	23
Source	Tester	P_2	Vehicle (ECU 1)	P_2	Vehicle (ECU 2)	P_3	Tester	P_2	Vehicle (ECU 1)	P_2	Vehicle (ECU 2)
Parameter	Message one	Response one	Response one	Response two	Message two	Response three	Response four				

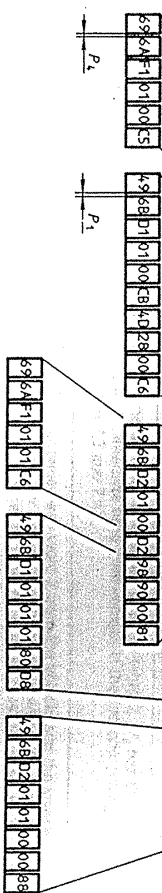

Interbyte and intermessage times: see annex A.

Figure 10 — Worked example

Annex A
(normative)

Tables of initialization, header and protocol timings, and electrical characteristics

In tables A.1 and A.2, all times are measured from the end of the stop bit of one byte to the falling edge of the start bit of the next byte.

Table A.1 — Minimum and maximum values of initialization and header timings

Symbol	Time ms		Description
	min.	max.	
W_0	2	∞	Bus "high" idle time prior to transmission of address byte (see clause 6)
W_1	60	300	Time from the end of the address byte to start of synchronization pattern (see 7.2 and 7.4)
W_2	5	20	Time from the end of the synchronization pattern to the start of key word 1. W_2 has the same time limits as P_4 in the protocol specification (see 7.2 and 7.4)
W_3	0	20	Time between key word 1 and key word 2. W_3 has the same limits as P_1 (interbyte time from vehicle) in the protocol timing specification (see 7.3 and 7.4)
W_4	25	50	Time between key word 2 from the vehicle and the inversion being returned by the tester. Also the time between the inverted key word 2 from the tester and the inverted address from the vehicle. W_4 has the same limits as P_2 (08) in the protocol timing specification (see 7.3 and 7.4)
W_5	300	—	Time that bus remains idle prior to the tester retransmitting an address byte

NOTE — Worst case initialization and header time is 2,44 s ($= W_0 + W_1 + W_2 + W_3 + 2 \times W_4 +$ transmission times).

Table A.2 — Minimum and maximum values of protocol timing

Symbol	Time		Description
	min.	max.	
P_1	0	20 ms	Interbyte time for messages from the vehicle to the diagnostic tester (see clause 12)
P_2 (94)	0	50 ms	Intermessage time for vehicles with key word of 94h (see clauses 12 and 13)
P_2 (08)	25 ms	50 ms	Intermessage time for vehicles with key word of 08h (see clauses 12 and 13)
P_3	55 ms	5 s	Intermessage time between the end of all vehicle-sourced responses and the start of the next diagnostic tester request (see clauses 12 and 13)
P_4	5 ms	20 ms	Interbyte time for messages from the diagnostic tester to the vehicle (see clauses 12 and 13)

Table A.3 — Electrical characteristics — Capacitances

Symbol	Capacitance		Description
	min.	max.	
C_{TE}	0	2 nF	Total capacitance of diagnostic tester and all its cabling (see clauses 5 and 8)
C_{oaw}	0	2 nF	Total capacitance of on-board wiring (see clauses 5 and 9)
C_{ecu}	0	5,6 nF	Total capacitance sum of all ECUs on the vehicle bus (see clauses 5 and 9)
C_{ecu}	0	500 pF	Recommended capacitance value per line K and L for an individual ECU (see clause 9)

NOTE — Capacitances are measured with respect to vehicle signal ground.

Table A.4 — Electrical characteristics — Resistances

	Resistance		Description
	min.	max.	
	510 Ω \pm 5 %		Tester pull-up to V_g for lines K and L (see clause 8)
100 k Ω	∞		ECU pull-up to V_g for lines K and L (if fitted) (see clause 9)
50 k Ω	∞		ECU pull-down to vehicle signal ground for lines K and L (if used) (see clause 9)