

INTERNATIONAL  
STANDARD

ISO  
9141-3

First edition  
1998-12-15

---

---

Road vehicles — Diagnostic systems —

**Part 3:**

Verification of the communication between  
vehicle and OBD II scan tool

*Véhicules routiers — Systèmes de diagnostic —*

*Partie 3: Vérification de la communication entre un véhicule et un outil  
d'analyse OBD II*



1999年3月18日

Reference number  
ISO 9141-3:1998(E)

## Contents

1 Scope .....	1
2 Normative references .....	1
3 Definitions and abbreviations .....	1
4 General.....	2
4.1 Test procedure overview.....	2
4.1.1 Message structure test.....	2
4.1.2 Initialization test.....	2
4.1.3 Physical layer test.....	2
4.2 Test conditions .....	2
4.2.1 General test conditions .....	2
4.2.2 Digital storage oscilloscope requirements .....	2
4.2.3 Power supply requirements.....	2
4.2.4 Network access device requirements.....	3
5 Message structure test.....	3
5.1 Purpose.....	3
5.2 Equipment .....	3
5.3 Test set-up.....	3
5.4 Procedure .....	3
5.4.1 OBD II scan tool .....	3
5.4.2 Vehicle .....	4
6 Initialization test.....	6
6.1 Purpose.....	6
6.2 Equipment .....	6
6.3 Test set-up.....	6

© ISO 1998

All rights reserved. Unless otherwise specified, no part of this publication may be reproduced or utilized in any form or by any means, electronic or mechanical, including photocopying and microfilm, without permission in writing from the publisher.

International Organization for Standardization  
Case postale 56 • CH-1211 Genève 20 • Switzerland  
Internet iso@iso.ch

Printed in Switzerland

6.4 Procedure .....	6
6.4.1 OBD II scan tool .....	6
6.4.2 Vehicle .....	7
7 Physical layer test .....	8
7.1 Purpose .....	8
7.2 Equipment .....	8
7.3 Procedure .....	8
7.3.1 OBD II scan tool .....	8
7.3.2 Vehicle .....	10
Annex A (normative) Test set-ups .....	13
Annex B (normative) Messages for use in verification test .....	15
Annex C (normative) Test parameter values .....	16
Annex D (normative) Network access device (NAD) — Minimum requirements .....	17
Annex E (informative) Bibliography .....	19

## Foreword

ISO (the International Organization for Standardization) is a worldwide federation of national standards bodies (ISO member bodies). The work of preparing International Standards is normally carried out through ISO technical committees. Each member body interested in a subject for which a technical committee has been established has the right to be represented on that committee. International organizations, governmental and non-governmental, in liaison with ISO, also take part in the work. ISO collaborates closely with the International Electrotechnical Commission (IEC) on all matters of electrotechnical standardization.

Draft International Standards adopted by the technical committees are circulated to the member bodies for voting. Publication as an International Standard requires approval by at least 75 % of the member bodies casting a vote.

International Standard ISO 9141-3 was prepared by Technical Committee ISO/TC 22, *Road vehicles*, Subcommittee SC 3, *Electrical and electronic equipment*.

ISO 9141 consists of the following parts, under the general title *Road vehicles — Diagnostic systems*:

- *Part 2: CARB requirements for interchange of digital information*
- *Part 3: Verification of the communication between vehicle and OBD II scan tool*

NOTE ISO 9141:1989, *Road vehicles — Diagnostic systems — Requirements for interchange of digital information* is regarded as being part 1 of this International Standard.

Annexes A to D form an integral part of this part of ISO 9141. Annex E is for information only.

# Road vehicles — Diagnostic systems —

## Part 3:

## Verification of the communication between vehicle and OBD II scan tool

### 1 Scope

This part of ISO 9141 establishes recommended test methods, test procedures and specific test parameters in order to verify a vehicle or OBD II scan tool can communicate on a bus according to ISO 9141-2. It is not applicable as a test for a single module or for any subpart of an ISO 9141-2 network.

The test described is not provided to verify any tool or vehicle requirement not described in ISO 9141-2. In particular it does not check any requirement described in SAE J1962, SAE J1978, ISO 15031-5 or the expanded diagnostic protocol for scan tool.

The procedures and methods test a set of specific requirements applicable to all road vehicles and scan tools which make use of ISO 9141-2.

### 2 Normative references

The following standards contain provisions which, through reference in this text, constitute provisions of this part of ISO 9141. At the time of publication, the editions indicated were valid. All standards are subject to revision, and parties to agreements based on this part of ISO 9141 are encouraged to investigate the possibility of applying the most recent editions of the standards indicated below. Members of IEC and ISO maintain registers of currently valid International Standards.

ISO 9141:1989, *Road vehicles — Diagnostic systems — Requirements for interchange of digital information.*

ISO 9141-2:1994, *Road vehicles — Diagnostic systems — Part 2: CARB requirements for interchange of digital information*, and its Amendment 1:1996.

ISO 15031-5:—<sup>1)</sup>, *Road vehicles — Emission-related diagnostics — Communication between vehicle and external equipment — Part 5: Emission-related diagnostic services.*

SAE J1962:1995, *Diagnostic Connector.*

SAE J1978:1994, *OBD II Scan Tool.*

### 3 Definitions and abbreviations

For the purposes of this part of ISO 9141, the definitions given in ISO 9141:1989 and the following abbreviations apply.

DSO Digital storage oscilloscope

---

1) To be published.

DUT	Device under test
NA	Not applicable
NAD	Network access device
PC	Personal computer
PID	Parameter identifier
PS	Power supply

## 4 General

### 4.1 Test procedure overview

Three test procedures are identified to test ISO 9141-2 implementations. The following is a short synopsis of the purpose of each of the tests.

#### 4.1.1 Message structure test

The message structure test verifies that the DUT responds correctly to both correct and incorrect messages generated by the NAD. This includes both the correct logical response and the correct response or request message.

#### 4.1.2 Initialization test

The initialization test verifies that the DUT can complete the initialization sequence with correct timing and that it responds correctly to errors from the vehicle or the OBD II scan tool.

#### 4.1.3 Physical layer test

The physical layer test verifies that the DUT shall receive and transmit data within physical parameter limits specified in ISO 9141-2.

### 4.2 Test conditions

#### 4.2.1 General test conditions

The maximum electrical vehicle load shall be as specified in ISO 9141:1989.

The tests shall be conducted when the DUT is stable within the operating range specified in ISO 9141-2:1994, 8. If a vehicle is being tested then it shall be stationary and with engine idling for the duration of the process unless specified otherwise for an individual test.

#### 4.2.2 Digital storage oscilloscope requirements

The DSO shall meet the following physical parameters:

- 20 pF maximum,
- 10 M $\Omega$  minimum,
- 50 MHz minimum.

#### 4.2.3 Power supply requirements

The PS shall be capable of supplying 5 A in a voltage range between 0 V and 20 V.

#### 4.2.4 Network access device requirements

The NAD shall be able to access and monitor the bus, display the initialization sequence and all messages. The NAD is used to simulate the ISO 9141-2 behaviour of an OBD II scan tool or a vehicle. For more information, refer to annex D.

Any inaccuracy in the NAD will result in possible errors in simulating and measuring timing, voltage and current limits. This document accommodates the non-ideal NAD by adjusting these limits according to the tolerance of the NAD ( $\Delta$ NAD, see annex C). This adjustment necessarily narrows the range of acceptable DUT behaviour to prevent a positive indication for a DUT that may fail in the field.

Conversely a good DUT may be rejected due to a large  $\Delta$ NAD. For this reason it is recommended that a NAD is selected which has the smallest  $\Delta$ NAD.

### 5 Message structure test

#### 5.1 Purpose

The message test verifies that the DUT transmits and interprets correctly messages whose structure and timing are standardized in ISO 9141-2. Additionally, this test verifies that the DUT responds correctly to message structure and message timing errors.

#### 5.2 Equipment

- NAD,
- PS.

#### 5.3 Test set-up

- Connect the communication lines of the NAD to the DUT.
- If the DUT is an OBD II scan tool, connect it as shown in figure A.1.
- If the DUT is a vehicle, connect it as shown in figure A.2.
- Set PS to  $13,5 \text{ V} \pm 0,5 \text{ V}$ .

#### 5.4 Procedure

##### 5.4.1 OBD II scan tool

###### 5.4.1.1 Message structure test

Configure the NAD as a simulated vehicle with key bytes 08 08 and communication timing parameters  $P_1 = 10 \text{ ms}$ ,  $P_2 = 30 \text{ ms}$ . Cause the scan tool to initialize the simulated vehicle, as described in ISO 9141-2:1994, clauses 6 and 7. Cause the OBD II scan tool to transmit a request message mode 1 PID 0 (request current powertrain data). Configure the NAD to respond with the simulated vehicle response messages shown in table 1. Verify the OBD scan tool behaviour according to table 1.

###### 5.4.1.2 Message timing test

Configure the NAD as a simulated vehicle with keybytes 08 08. Cause the scan tool to initialize the simulated vehicle, as in ISO 9141-2:1994, clauses 6 and 7. Cause the OBD II scan tool to transmit a request message mode 1 PID 1 (request current powertrain data). Configure the NAD to respond with the simulated vehicle response message 48 6B D1 41 00 CB 4D 28 00 06 using the timing parameter values shown in table 2. Verify the OBD scan tool behaviour according to table 2.

Table 1 — Message structure test for OBD II scan tool

NAD (simulated vehicle response message)	Verification	Reference to ISO 9141-2: 1994
Respond with correct message: 48 6B D1 41 00 CB 4D 28 00 06 (hex.)	Verify that the transmitted test message request on the bus corresponds to the test message request as shown in annex B. Verify $P_4$ to be in range.	Clauses 1 and 12
Respond with incorrect checksum byte: 48 6B D1 41 00 CB 4D 28 00 00 (hex.)	Verify that the OBD II scan tool retransmits the original request message $P_3$ after the completion of the last received byte (checksum byte). Verify $P_3$ to be in range between $P_{3(min.)}$ and $P_{3(max.)} - x\%$ . Verify that the OBD II scan tool continues to retry for at least 1 min.  NOTE — $x\%$ is not specified in ISO 9141-2. It is recommended that $x\%$ is set at least to 10 % for this test. This is done to guarantee interoperability.	Subclause 13.2.1
Respond with incorrect 1st header byte: 49 6B D1 41 00 CB 4D 26 00 06 (hex.)		Subclause 13.2.2
Respond with incorrect length (too short): 48 6B D1 41 00 CB 4D 28 06 (hex.)		
Respond with incorrect length (too long): 48 6B D1 41 00 CB 4D 28 00 00 06 (hex.)		

Table 2 — Message timing test for OBD II scan tool

NAD (simulated vehicle response message)	Verification	Reference to ISO 9141-2: 1994
Respond with minimum $P_1$ period: $P_1 = P_{1(min.)}$	Verify that the OBD II scan tool received the response message correctly, e.g. displays the message according to ISO 15031-5 or displays the message at hex. level.	Clause 13
Respond with maximum $P_1$ period: $P_1 = P_{1(max.)} + \Delta NAD$		Clause 13
Respond with minimum $P_2$ period: $P_2 = P_{2(08min.)} - \Delta NAD$		Clause 13
Respond with maximum $P_2$ period: $P_2 = P_{3(min.)} + \Delta NAD$		Clause 13
Respond with incorrect long $P_1$ period: $P_1 = P_{2(min.)} - \Delta NAD$	Verify that the OBD II scan tool retransmits the original request message $P_3$ after the completion of the last received byte (checksum byte). Verify $P_3$ to be in range between $P_{3(min.)}$ and $P_{3(max.)} - x\%$ . Verify that the OBD II scan tool continues to retry for at least 1 min.	Subclause 13.2.13
Do not respond.	NOTE — $x\%$ is not specified in ISO 9141-2. It is recommended that $x\%$ is set at least to 10 % for this test. This is done to guarantee interoperability.	

5.4.2 Vehicle

5.4.2.1 Message structure test

Configure the NAD as a simulated OBD II scan tool with communication timing parameters  $P_3 = 60$  ms,  $P_4$ . Cause the simulated scan tool to initialize the vehicle, as described in ISO 9141-2:1994, clauses 6 and 7. Cause the vehicle behaviour according to table 3 using the correct test message responses shown in annex B.



Table 3 — Message structure test for vehicle

NAD (simulated OBD II scan tool messages)	Verification	Reference to ISO 9141-2:1994
Transmit correct message: 68 6A F1 01 00 C4 (hex.)	Verify that vehicle responds with correct response message (see annex B). Verify that timings $P_1$ and $P_2$ are in range.	Clauses 11 and 12
Transmit message with incorrect checksum byte: 68 6A F1 01 00 C5 (hex.) and 300 ms later with correct message	Verify that vehicle responds $P_2$ after the completion of the last byte of the correct message.	Subclause 13.2.1
Transmit message with incorrect length (too short): 68 6A F1 01 C4 (hex.) and 300 ms later with correct message: 68 6A F1 01 00 C4 (hex.)		Subclause 13.2.2
Transmit message with incorrect length (too long): 68 6A F1 01 00 00 C4 (hex.) and 300 ms later with correct message: 68 6A F1 01 00 C4 (hex.)		Subclause 13.2.2

## 5.4.2.2 Message timing test

Configure the NAD as a simulated OBD II scan tool. Cause the simulated scan tool to initialize the vehicle, as ISO 9141-2:1994, clauses 6 and 7. Cause the simulated OBD II scan tool to transmit a request message 68 6A F1 01 00 C4 with the timing parameters given in table 4. Verify the vehicle behaviour according to table using the correct test message responses shown in annex B.

Table 4 — Message timing test for vehicle

NAD (simulated OBD II scan tool messages)	Verification	Reference to ISO 9141-2:1994
Transmit test message request with minimum $P_4$ period: $P_4 = P_{4(\min.)} - \Delta\text{NAD}$	Verify that vehicle responds with correct response message (see annex B). Verify that timing $P_2$ is in range.	Clause 12
Transmit test message request with maximum $P_4$ period: $P_4 = P_{4(\max.)} + \Delta\text{NAD}$		Clause 12
Transmit test message request with minimum $P_3$ period: $P_3 = P_{3(\min.)} - \Delta\text{NAD}$		Clause 12
Transmit test message request with maximum $P_3$ period: $P_3 = P_{3(\max.)} + x\%$		Clause 12
Transmit test message request with incorrect long $P_4$ period: $P_4 = P_{2(\min.)} - \Delta\text{NAD}$ and 300 ms later with correct $P_4$ period	Verify that vehicle responds $P_2$ after the completion of the last byte of the correct message.	Subclause 13.2.3
Transmit test message request with incorrect long $P_3$ period: $P_3 = P_{3(\max.)} + x\%$	Vehicle shall not respond.	Subclause 13.2.5

NOTE —  $x\%$  is not defined in ISO 9141-2. It is recommended that  $x\%$  shall not exceed 10 % for this test.

## 6 Initialization test

### 6.1 Purpose

The initialization test verifies that the DUT handles correctly the initialization sequence and that it responds correctly if errors occur in the sequence.

### 6.2 Equipment

- NAD,
- 2 DSO.

### 6.3 Test set-up

- Connect the communication lines of the NAD to the DUT.
- If the DUT is an OBD II scan tool, connect it as shown in figure A.1.
- If the DUT is a vehicle, connect it as shown in figure A.2.
- Set PS to  $13,5\text{ V} \pm 0,5\text{ V}$ .
- Connect the DSO to K and L as shown in annex A.

### 6.4 Procedure

#### 6.4.1 OBD II scan tool

The NAD shall be set up to respond as shown in table 5. The OBD II scan tool shall be set up as if just connected to the vehicle so as to cause it to start the initialization sequence, i.e. to send the address byte  $33_{\text{hex}}$ . The parameters to be measured are indicated in table 5. Note that the order of these tests is free but that the OBD II scan tool has to be disconnected or reset following a successful initialization.

Table 5 — Initialization timings and parameter settings

NAD (simulated vehicle behaviour) simulated vehicle response								Verification	Referen- to ISO 914 1994
$W_1$	Sync	$W_2$	KW 1	$W_3$	KW2	$W_4$	inv. Addr		
$W_{1(min.)} - \Delta NAD$	55 hex.	$W_{2(min.)} - \Delta NAD$	08 hex.	0	08 hex.	$W_{4(min.)} - \Delta NAD$	CC hex.	Verify parameter address, $BT_5$ , $BR_1$ , $V_{H(min.)}$ , $V_{H(max.)}$ , $V_{L(min.)}$ , $V_{L(max.)}$	Subclau 5.1; clau 6, 7 and
			94 hex.		94 hex.		CC hex.		
$W_{1(max.)} + \Delta NAD$		$W_{2(max.)} + \Delta NAD$	08 hex.	$W_{3(max.)} + \Delta NAD$	08 hex.	$W_{4(max.)} + \Delta NAD$	CC hex.	Verify parameter KW2 inv., $P_3$ , $W_4$ (OBD II scan tool)	
No action								Verify that the OBD II scan tool does not retransmit the address before $W_{5(min.)}$	Subclau 13.1
$W_{1(min.)} - \Delta NAD$	Stop transmission								
60	55 hex.	$W_{2(min.)} - \Delta NAD$	08 hex.	Stop transmission					
$W_{1(min.)} - \Delta NAD$			$\neq 08$ hex.	0	08 hex.	Stop transmission			
						08 hex.	$W_{4(min.)} - \Delta NAD$	$\neq CC$ hex.	

NOTE — The OBD II scan tool verification of the sync pattern is intentionally excluded from the test.

6.4.2 Vehicle

- Configure the NAD to send the address  $33_{hex.}$  at  $BR_{5(max.)}$  on both the K- and L-line.
- Capture the vehicle responses.
- Verify that there are three bytes.
- Verify the time  $W_1$  between the end of the address and the start of the first byte, the time  $W_2$  between the first and second bytes of the response and the time  $W_3$  between the second and third bytes of the response.
- Verify the values of the bytes are SYNC, KW1 and KW2 respectively.
- Verify the values of the following parameters:  $V_{H(min.)}$ ,  $V_{H(max.)}$ ,  $V_{L(min.)}$ ,  $V_{L(max.)}$ ,  $BT_F$  on the K-line.  $BT_F$  needs to be within tolerance for each bit of the sync byte.
- Set the NAD to allow 300 ms to elapse and then retransmit the address at  $BR_{5(min.)}$  on both the K- and L-lines
- Set the NAD to respond to the vehicle response by transmitting the inversion of the last value of the last byte of the vehicle response  $W_{4(min.)}$  after the end of the vehicle response.
- Capture the vehicle responses.
- Verify that the values of the bytes are SYNC, KW1, KW2.

- Verify the time  $W_4$  between the end of the second NAD transmission and the subsequent vehicle response.
- Verify that the second vehicle response is a single byte.
- Verify that the value is the inverted address.

## 7 Physical layer test

### 7.1 Purpose

The physical layer test is to verify that the OBD II scan tool or the vehicle receives and transmits at the physical layer parameters specified in ISO 9141-2.

### 7.2 Equipment

- NAD,
- DSO,
- PS,
- ampere meter.

### 7.3 Procedure

#### 7.3.1 OBD II scan tool

##### a) Resistance test

Set up test equipment as indicated in figure 1. Verify the resistance to  $V_B$  of the K- and L-line,  $R_{+TE}$  by measuring the voltage  $V_x$  on the DSO.

It is recommended that  $R_L$  be 510  $\Omega$ .

Verify  $R_{+TE}$ :

$$R_{+TE} = R_L \frac{V_B}{V_x - 1}$$

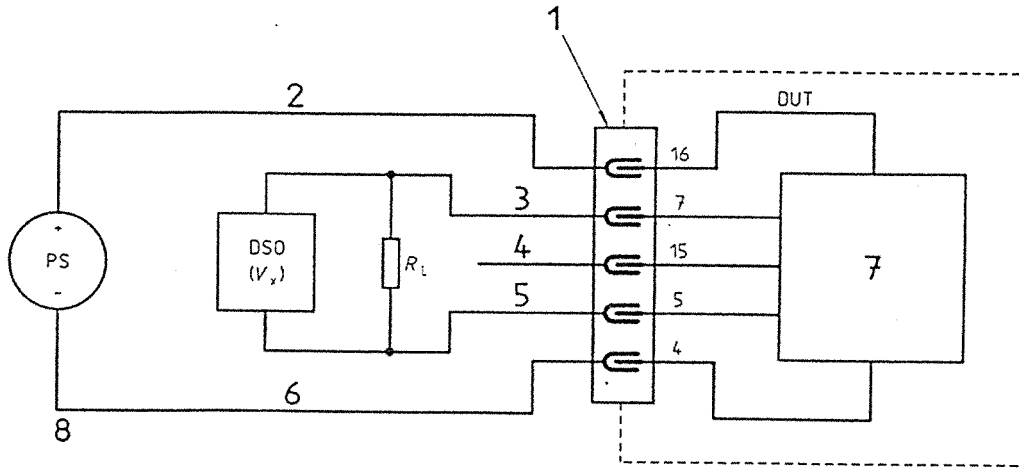

**Key**

- |                                    |                               |
|------------------------------------|-------------------------------|
| 1 Connector according to SAE J1962 | 5 Signal GND                  |
| 2 Unswitched $V_B$                 | 6 Chassis GND                 |
| 3 K-line                           | 7 Scan tool                   |
| 4 L-line                           | 8 Repeat as K-line for L-line |

Figure 1 — Scan tool resistance test set-up

**b) Capacitance test**

Set up test equipment as indicated in figure 2. Verify the capacitance to signal GND of K-line,  $C_{TE}$ .

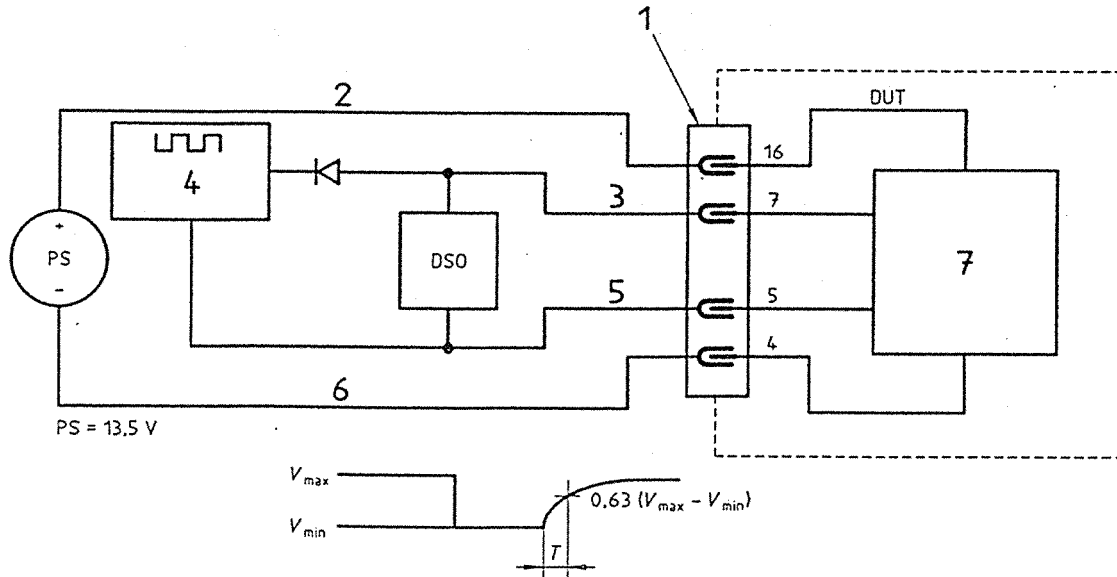

**Key**

- |                                    |               |
|------------------------------------|---------------|
| 1 Connector according to SAE J1962 | 5 Signal GND  |
| 2 Unswitched $V_B$                 | 6 Chassis GND |
| 3 K-line                           | 7 Scan tool   |
| 4 Signal generator                 |               |

Figure 2 — Scan tool capacitance test set-up

Verify that:  $T < R_{+TEmax} \times C_{TEmax}$ .

c) Voltage and rise time test

Connect the equipment according to figure A.1. Configure the NAD to respond with the specific test response message given in table B.1 with the settings given in the table 6. Cause the OBD II scan tool to initialize the simulated vehicle. Force the OBD II scan tool to send mode 1 PID 0 (request current powertrain data) continuously. Verify the values indicated by an \* in the table are within the tolerances given in annex C and that the OBD II scan tool displays the correct response continually, throughout the test.

Note that for each test the OBD II scan tool shall be reset and forced to reinitialize the NAD.

Table 6 — Scan tool voltage and rise time test, settings

Test no.	NAD settings					Scan tool measurements				
	PS V	TT	V <sub>L</sub>	V <sub>H</sub>	BR <sub>OB</sub>	V <sub>L</sub> /V <sub>H</sub>	TT <sub>+ve</sub>	TT <sub>-ve</sub>	BR <sub>TE</sub>	Comms OK
1	8	max. + ΔNAD	max. + ΔNAD	min. - ΔNAD	$BR_{OB(max.)} \leq BR$ $\leq (1 + \alpha_{BR}) BR_{OB(max.)}$	*				*
2	13,5				$BR_{OB(max.)} \leq BR$ $\leq (1 + \alpha_{BR}) BR_{OB(max.)}$	*	*	*	*	*
3	16 <sup>1)</sup>				$BR_{OB(max.)} \leq BR$ $\leq (1 + \alpha_{BR}) BR_{OB(max.)}$	*				*
4	13,5				$(1 - \alpha_{BR}) BR_{OB(min.)}$ $\leq BR \leq BR_{OB(min.)}$				*	*

1) For this test add an R<sub>load</sub> resistor as shown in figure A.1.

\* Indicates values to be verified, see 7.3.1 c).

7.3.2 Vehicle

a) Resistance test

Set up test equipment as indicated in figure 3. Verify the resistance to V<sub>B</sub> of K- and L-line, R<sub>+OB</sub> and the resistance to signal ground of K- and L-line R<sub>-OB</sub>.

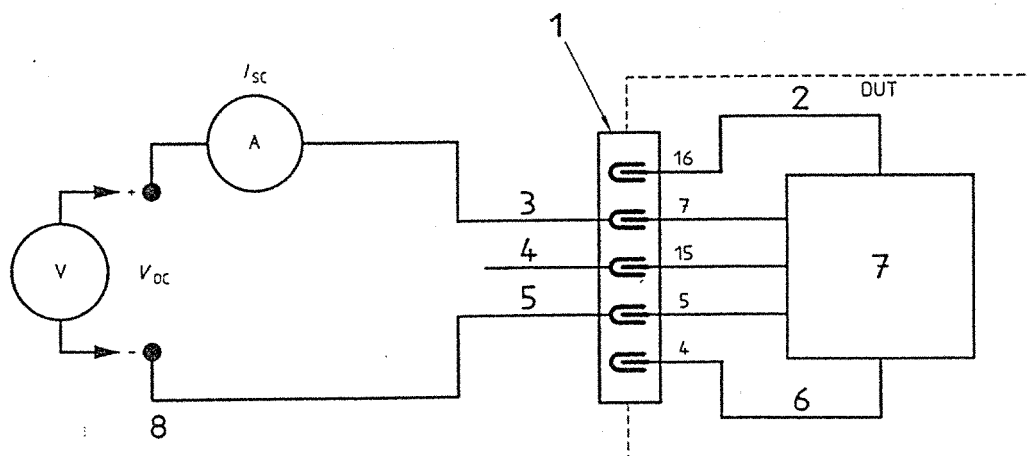

Key

- 1 Connector according to SAE J1962
- 2 Unswitched V<sub>B</sub>
- 3 K-line
- 4 L-line
- 5 Signal GND
- 6 Chassis GND
- 7 Vehicle
- 8 Repeat as K-line for L-line

Figure 3 — Vehicle resistance test set-up

Measure  $V_B$  and  $I_{SC}$  to verify that

$$\frac{V_B}{I_{SC}} \geq R_{+OBmin.}$$

and

$$V_B \frac{V_{OC}}{I_{SC}(V_B - V_{OC})} \geq R_{-OB}$$

**b) Capacitance test**

Set up test equipment as indicated in figure 4. Verify the capacitance to signal GND of K-line,  $C_{OB}$ .

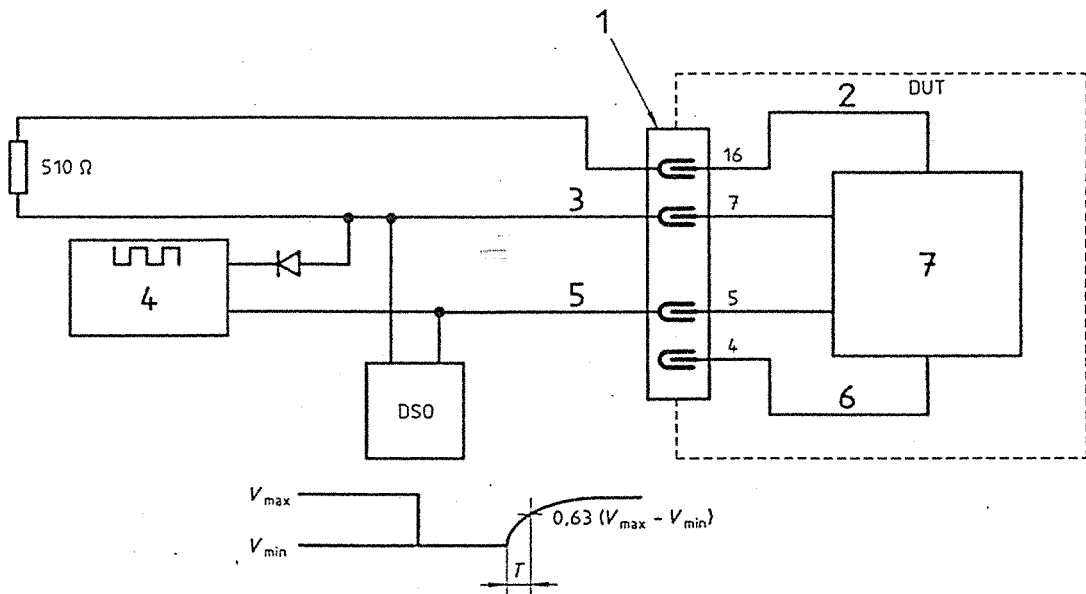

**Key**

- |                                    |               |
|------------------------------------|---------------|
| 1 Connector according to SAE J1962 | 5 Signal GND  |
| 2 Unswitched $V_B$                 | 6 Chassis GND |
| 3 K-line                           | 7 Vehicle     |
| 4 Signal generator                 |               |

**Figure 4 — Vehicle capacitance set-up**

Verify that:  $T < R_{test} \times C_{OBmax.}$

**c) Voltage and rise time test**

Connect the equipment according to figure A.2. Configure the NAD to send the specific test request message in table B.1 with the settings given in the table 7. Cause the NAD to initialize the vehicle. Cause the NAD to send the specific test request message continuously. Verify the values indicated by an \* in table 7 are within the tolerance given in annex C and that the vehicle response message received by the NAD is correct.

Note that for each test the NAD shall be reset and forced to reinitialize the vehicle.

Table 7 — Vehicle voltage and rise time test, settings

Test No.	NAD Settings				Vehicle measurements			
	TT	V <sub>L</sub>	V <sub>H</sub>	BR <sub>TE</sub>	V <sub>L</sub> /V <sub>H</sub>	TT <sub>ve</sub>	BR <sub>OB</sub>	Comms OK
1	max. + ΔNAD	max. + ΔNAD	min. + ΔNAD	BR <sub>TE(max.)</sub> ≤ BR ≤ (1 + α <sub>BR</sub> ) BR <sub>TE(max.)</sub>	*	*	*	*
2	max. + ΔNAD	max. + ΔNAD	min. + ΔNAD	(1 - α <sub>BR</sub> ) BR <sub>TE(min.)</sub> ≤ BR ≤ BR <sub>TE(min.)</sub>				*

\* Indicates values to be verified, see 7.3.2 c).



## Annex A (normative)

### Test set-ups

Figures A.1 and A.2 show the test set-ups referenced in the procedures.

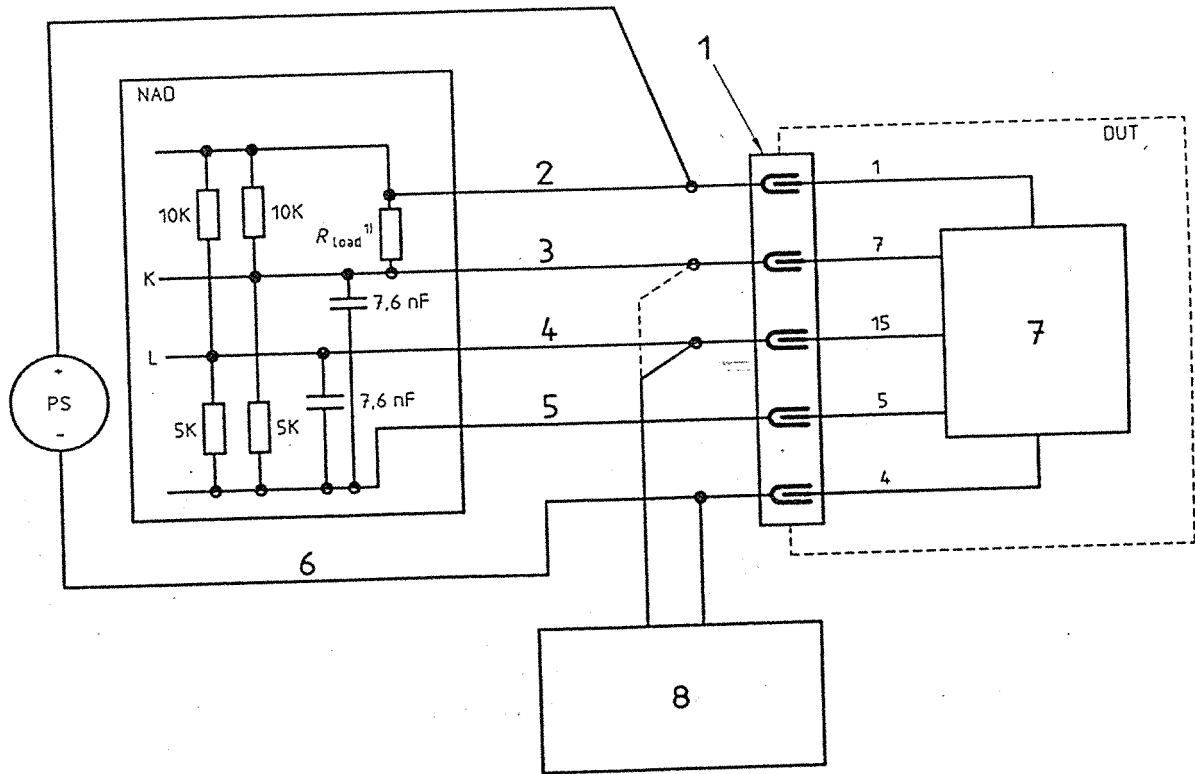

**Key**

- |                                    |                |
|------------------------------------|----------------|
| 1 Connector according to SAE J1962 | 5 Signal GND   |
| 2 Unswitched V <sub>B</sub>        | 6 Chassis GND  |
| 3 K-line                           | 7 Scan tool    |
| 4 L-line                           | 8 Oscilloscope |

1) This is only required for the physical layer test of the OBD II scan tool (see table 6).

**Figure A.1 — Set-up for scan tool verification tests**

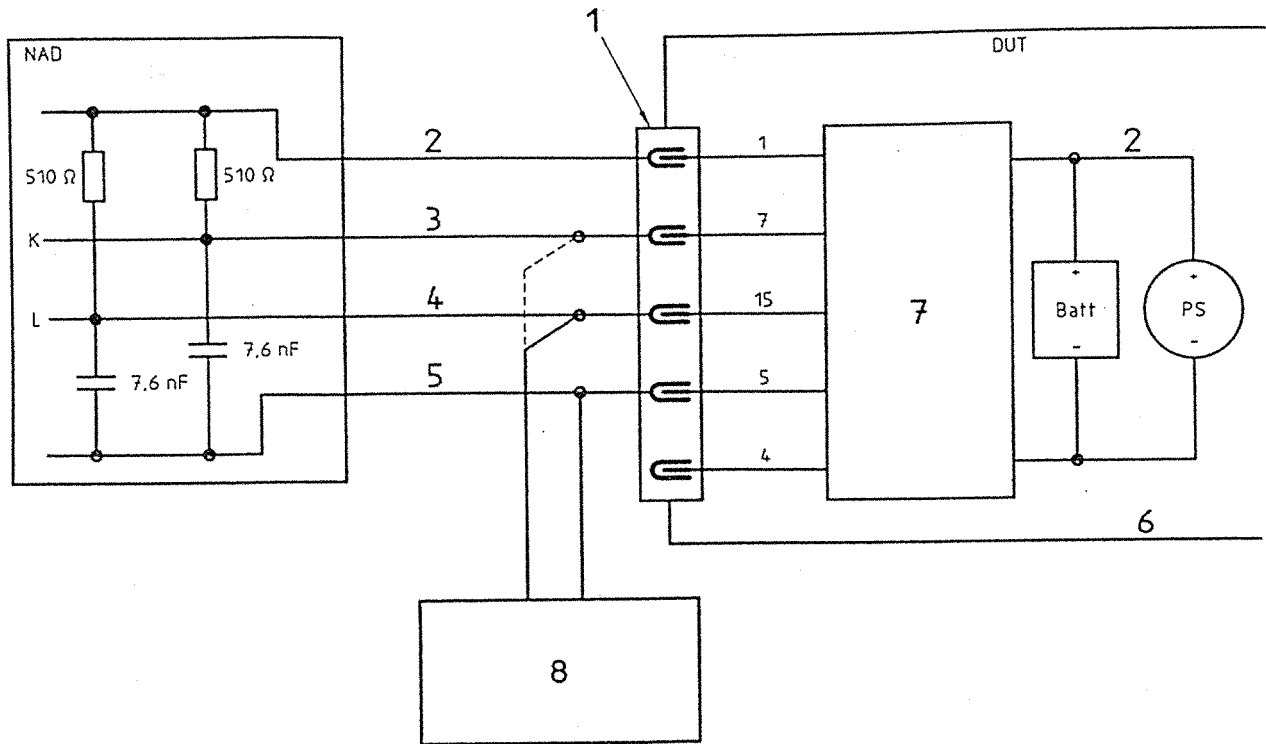

Key

- 1 Connector according to SAE J1962
- 2 Unswitched  $V_B$
- 3 K-line
- 4 L-line

- 5 Signal GND
- 6 Chassis GND
- 7 Vehicle
- 8 Oscilloscope

Figure A.2 — Set-up for vehicle verification tests

## Annex B (normative)

### Messages for use in verification test

Table B.1 describes proper test messages which are to be used in verification test.

Table B.1 — Messages for verification test

Message	
Title	Value in hex.
General test message request	68 6A Fx 01 00 xx
Specific test message request	68 6A F1 01 00 C4
General test message response	48 6A xx 41 00
Specific test message response	48 6A D1 41 00 01 02 03 04 CE
x = User defined value.	

## Annex C (normative)

### Test parameter values

Values of test parameters are specified in table C.1.

Table C.1 — Test parameter values

Parameter	Symbol	Parameter value		Unit	Reference to ISO 9141-2 and note
		min.	max.		
Voltage high receive threshold	$V_{HRx}$	$0,7 V_B$	$V_B$	V	
Voltage high transmit scan tool threshold	$V_{HTx}$	$0,9 V_B$		V	Subclause 8.3.1
Voltage high transmit vehicle threshold	$V_{HTx}$	$0,8 V_B$		V	Subclause 5.1
Voltage low receive threshold	$V_{LRx}$		$0,3 V_B$	V	
Voltage low transmit vehicle threshold	$V_{LTxOB}$	0	$0,2 V_B$	V	Subclause 8.3.1
Voltage low transmit scan tool threshold	$V_{LTxTE}$		$0,1 V_B$	V	Subclause 5.1
Bit rate	$BR_5$	4 975	5 025	bit/s	Subclause 8.2 c)
Bus idle time	$W_0$	2	$\infty$	ms	Table A.1
Synchronisation delay	$W_1$	60	300	ms	Table A.1
Keyword 1 delay	$W_2$	5	20	ms	Table A.1
Keyword 2 delay	$W_3$	0	20	ms	Table A.1
Inter-byte delay	$W_4$	25	50	ms	Table A.1
Bus idle time (address retransmitting)	$W_5$	300	$\infty$	ms	Table A.1
Tester bus line capacitance	$C_{TE}$	0	2	nF	Subclause 8.3.6
Tester bus line resistance to $V_B$	$R_{+TE}$	485	515	$\Omega$	Nominal 510 $\Omega$
Rise time	$TT+$	0	$0,1/BR$	$\mu s$	Subclause 5.1
Fall time	$TT-$	0	$0,1/BR$	$\mu s$	Subclause 5.1
Tester bit rate	$BR_{TE}$	10 348	10 452	bit/s	Subclause 8.3.2
Table A.2	$P_1$	0	20	ms	
Table A.2	$P_2 (94)$	0	50	ms	
Table A.2	$P_2 (08)$	25	50	ms	
Table A.2	$P_3$	55	5 000	ms	
Table A.2	$P_4$	5	20	ms	
Vehicle bus line capacitance	$C_{OB}$	0	7,2	nF	
Vehicle bus line resistance to $V_B$	$R_{+OB}$	10		k $\Omega$	
Vehicle bus line resistance to Ground	$R_{-OB}$	5		k $\Omega$	
Baud rate	$BR_{OB}$	10 223	10 577	bit/s	
$\Delta NAD$	$\Delta NAD$	0	1,25	ms	Recommended for interoperability
Sink current	$I_{sink}$	2		A	For ISO 9141-2 compatibility
	$I_{sink}$	100		mA	For SAE J1978 compatibility

## Annex D (normative)

### Network access device (NAD) — Minimum requirements

This annex describes the functions of an NAD. The NAD is used to simulate a tester or vehicle behaviour during ISO 9141-2 verification test. The NAD may be physically one or more devices, but will be referred to as a single in the following. The listed items shall be supported by the NAD:

- Configuration of a 5 Baud initialization sequence as tester, including the following configurable parameters:
  - set time values:  $W_0, W_4, W_5,$
  - max. waiting time values:  $W_1, W_2, W_3, W_{4a},$
  - byte values: initialization address.
- Configuration of a 5 Baud initialization sequence as vehicle, including the following configurable parameters
  - set time values:  $W_1, W_2, W_3, W_{4a},$
  - max. waiting time values:  $W_0, W_4, W_5,$
  - byte values: KW1, KW2.
- Baud rate. The following Baud rates shall be achievable:
  - $[1 - (\alpha_{BR}/2)] 10\,400 \text{ bit/s} \leq BR \leq [1 + (\alpha_{BR}/2)] 10\,400 \text{ bit/s}$
  - $(1 - \alpha_{BR}) BR_{OB(min.)} \leq BR \leq BR_{OB(min.)}$
  - $BR_{OB(max.)} \leq BR \leq (1 + \alpha_{BR}) BR_{OB(max.)}$
  - $(1 - \alpha_{BR}) BR_{TE(min.)} \leq BR \leq BR_{TE(min.)}$
  - $BR_{TE(max.)} \leq BR \leq (1 + \alpha_{BR}) BR_{TE(max.)}$

It is recommended that the value of  $\alpha_{BR}$  be no greater than 0,01.
- In the range 10,4 kBaud/s, with a relative tolerance of  $\pm 5\%$ . The data format shall be 8n1 (8 data bits, parity, one stop bit).
- Configuring a communication test sequence as tester and as vehicle including the following configurable parameters:
  - transmission byte(s): 0 bytes to 12 bytes (at least),
  - inter byte time:  $P_4$  resp.  $P_1,$
  - inter message time:  $P_3$  resp.  $P_2.$
- Running any test sequence.
- Time stamping of received/transmitted bytes with an accuracy and a resolution of at least 0,1 ms.

- Storing and/or displaying the bytes and affiliated time stamps.
- Bus line voltage. The following voltages shall be achievable:

$$(1 - \alpha_v) V_{HRx(min.)} \leq V \leq V_{HRx(min.)}$$

$$(1 - \alpha_v) V_{HTx(min.)} \leq V \leq V_{HTx(min.)}$$

$$V_{LRx(max.)} \leq V \leq (1 + \alpha_v) V_{LRx(max.)}$$

$$V_{LTxTE(max.)} \leq V \leq (1 + \alpha_v) V_{LTxTE(max.)}$$

$$V_{LTxOB(max.)} \leq V \leq (1 + \alpha_v) V_{LTxOB(max.)}$$

It is recommended that the value of  $\alpha_v$  be no greater than 0,01.

$$(V_{HRx(min.)} - \Delta NAD) \pm \Delta NAD$$

$$(V_{HTx(min.)} - \Delta NAD) \pm \Delta NAD$$

$$(V_{LRx(max.)} + \Delta NAD) \pm \Delta NAD$$

$$(V_{LTxTE(max.)} + \Delta NAD) \pm \Delta NAD$$

$$(V_{LTxOB(max.)} + \Delta NAD) \pm \Delta NAD$$

The voltage level for the  $\Delta NAD$  should be  $\leq 0,1$  V.

Adjusting the electrical parameters. The voltage levels for transmission shall be adjustable with a resolution and accuracy of 0,1 V. The logical high and low levels shall be configurable independently. The transition times shall be also adjustable independently with a resolution and an accuracy of 1 % in the range between 0 % and 10 % bit time.

All time values shall be configurable with an accuracy and a resolution of at least 0,1 ms.

## Annex E

(informative)

### Bibliography

- [1] ISO 15031-3:—<sup>2)</sup>, *Road vehicles — Emission-related diagnostics — Communication between vehicle and external equipment — Part 3: Diagnostic connector.*
- [2] ISO 15031-4:—<sup>2)</sup>, *Road vehicles — Emission-related diagnostics — Communication between vehicle and external equipment — Part 4: Scanning tool.*
- [3] SAE J1930:1995, *Electrical/Electronic Systems Diagnostic Terms, Definitions, Abbreviations and Acronyms.*
- [4] SAE J2178/1:1995, *Class B Data Communication Network Messages — Detailed Header formats and Physical Address Assignments.*

---

<sup>2)</sup> To be published.